



Kraftsteckschlüssel & Bits

**2022
2023**

ZEMO

www.zemo-tools.de



Über uns

Jahrzehntelange Erfahrung unserer Drehmomentspezialisten, kombiniert mit anerkannt hochwertigen Industriewerkzeugen und Drehmomentsystemen, unterstützt die Effizienz Ihrer Fertigungsprozesse durch kontrolliertes Verschrauben.

Ausgewählte Montagewerkzeuge und innovative Messtechnik in führender Industriequalität stehen bereit. Von bestens bewährten Drehmomentschlüsseln über exzellente Prüfgeräte, leistungsstarke Druckluftwerkzeuge und ultramoderne EC-Schraubsysteme bis hin zu individuellen Sonderlösungen nach Zeichnung.

Insbesondere bieten wir Ihnen eine fundierte persönliche Beratung sowie weit reichenden Service – von der individuellen Vorführung und kompetenten Betreuung vor Ort über die autorisierte Kalibrierung und Zertifizierung bis zur fachkundigen Reparatur und Wartung.

Seit Jahrzehnten werden die von uns gelieferten Markenwerkzeuge erfolgreich eingesetzt in der Fahrzeugproduktion, im Maschinenbau, aber auch in der Luft- und Raumfahrtindustrie sowie etlichen weiteren Industriezweigen.

Die in der industriellen Fertigung bevorzugten Werkzeuge spiegeln sich in unserer hochklassigen Produktlinie, ergänzt durch zuverlässige Druckluftschrauber für Wartungs- und Instandsetzungsarbeiten (Automotive).

Referenzen



- Effiziente Schraubtechnik
- Kontrollierte Schraubergebnisse
- Lean Production
- Service – Qualität – Kompetenz



Portfolio

- Bewährte Montagewerkzeuge in Industriequalität und hochklassige EC-Schraubsysteme
- Fundierte persönliche Beratung
- Kompetente Betreuung vor Ort
- Effektive Anwenderschulung
- Individuelle Vorführung, Probeinstallation, Inbetriebnahme
- Autorisierte Prüfung, Kalibrierung und Zertifizierung
- Fachkundige Wartung / Instandsetzung
- Info-Newsletter mehrmals jährlich



Weitere Infos auf unserer Website.



	Kraftsteckschlüssel	
	Vierkantantrieb 1/4"	8
	Vierkantantrieb 3/8"	12
	Vierkantantrieb 1/2"	20
	Vierkantantrieb 3/4"	31
	Vierkantantrieb 1"	36
	Vierkantantrieb 1,5"	41
	Vierkantantrieb 2,5"	43
	Kraftsteckschlüssel mit Magnet	
	Vierkantantrieb 1/4"	11
	Vierkantantrieb 3/8"	19
	Vierkantantrieb 1/2"	30
	Verbindungssteile	
	Verlängerungen	46
	Reduzierungen	48
	Gelenkadapter	49
	Schnellwechselhalter	50
	Bitadapter	51
	Bits & Co.	
	Nutsetter	52
	Vierkant-Adapter	54
	Bithalter	55
	Bits C 6,3	56
	Bits C 8	63
	Bits E 6,3	64
	Bits E 11,2	69
	Kraftsteckschlüssel mit Spindelführung (nur für Impulsschrauber)	
	Vierkantantrieb 3/8"	72
	Vierkantantrieb 1/2"	75
	Vierkantantrieb 3/4"	78
	Verbindungssteile	79
	Technische Tabellen	
	Zuordnung von Werkzeug und Maschine	80
	Prüfdrehmomente für Schraubwerkzeuge	81
	Umrechnung von Drehmomentwerten	82
	Richtwerte für Anzugsmomente	83



Weitere Infos auf unserer Website.



Was die Schraubverbindung beeinflusst

Vom Anzugsmoment zur Vorspannung

Das Funktionsprinzip einer geschraubten Verbindung besteht im Aufeinanderpressen mehrerer Bauteile oder Komponenten. Dabei wird die eingebrachte Eindrehkraft (Anzugsmoment) über das Schraubengewinde in einen Anpressdruck (Klemmkraft) umgesetzt, der auf die verschraubten Werkstücke wirkt.

Als **Drehmoment** (Md) bezeichnet man die physikalische Kraft, die über einen definierten Hebel rechtwinklig auf eine Drehachse wirkt (senkrechte Rotationsbeschleunigung). Das Drehmoment wird in Newtonmeter gemessen und ist das Vektorprodukt von Kraftarm mal Kraft.

Die **Vorspannung** (F) wirkt axial im Schraubenschaft zwischen Schraubenkopf und Schraubenmutter und erzeugt die **Klemmkraft**, mit welcher die zu verschraubenden Komponenten aufeinander gepresst werden. Ab dem Zeitpunkt, wo der Schraubenkopf bzw. die Schraubenmutter auf dem zu verschraubenden Material anliegt (Kopfauf- lage), wirkt die Vorspannung. Die Vorspannkraft bewirkt eine gleichbleibende und dauerhafte Verbindung der unterschiedlichen Werkstücke miteinander.



Handhabungsfehler und Umgebungseinflüsse

Ein häufiger Fehler bei der Handhabung von Schrauben ist, dass Verbindungselement und Werkzeug sich nicht im korrekten Winkel zueinander befinden. Häufig wird der Werkzeugtrigger (Startknopf) zu früh losgelassen, oder der Trigger wird doppelt betätigt. Gar nicht mal so selten kommt es auch zum doppelten Anzug ein und derselben Schraubverbindung.

Zu den häufigen Umgebungseinflüssen zählen neben Leckagen im Druckluftsystem, falsch gewählten Luftschlauch-Durchmessern und zu geringen Fließdruckkapazitäten auch verschlissene Steckschlüssel und/oder Verlängerungen.

Beim Einsatz von motorisierten Werkzeugen sollte man unbedingt auf verchromte Steckschlüssel und Adapter verzichten. Diese bergen ein hohes potenzielles Verletzungsrisiko.

Verwenden Sie in jedem Fall nur passgenaue Kraftsteckschlüssel. Der Antriebsvierkant des Kraftsteckschlüssels soll das gleiche Maß aufweisen wie der Abtriebsvierkant des Schraubers. Adapter und Reduzierstücke sollten möglichst vermieden werden.

Auch auf den guten Zustand der verwendeten Kraftsteckschlüssel sollte hohes Augenmerk gelegt werden. Verschlissene Steckschlüssel führen zu Drehmomentverlust, wodurch die Drehmomentwiederholgenauigkeit verringert wird, bewirken eine inkorrekte Verschraubungsposition und erzeugen zusätzliche Vibrationen mit den damit verbundenen Nachteilen und Risiken (z.B. RSI).

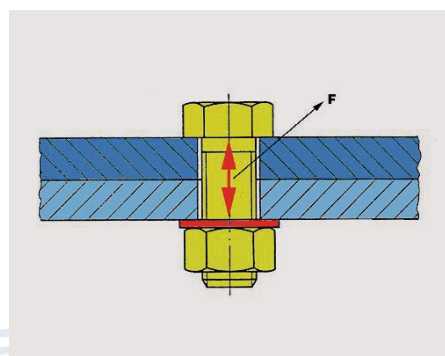
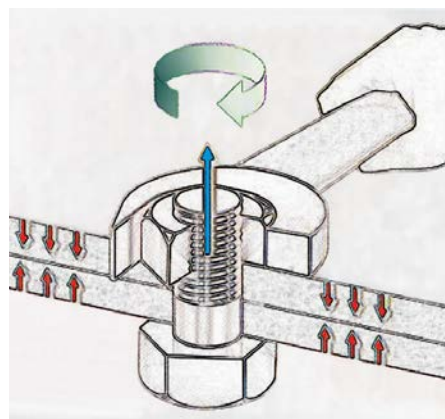

Das richtige Werkzeug

Schraubverbindungen sind komplexe physikalische Gefüge, in denen zahlreiche Einflussfaktoren mitbestimmend sind. Der größte Teil des aufgetragenen Drehmoments wird durch die Kopf- und Gewindereibung absorbiert. Nur ein kleiner Teil von etwa 10 % wird direkt in Vorspannkraft umgesetzt. Grundsätzlich gilt: je weicher der Schraubfall, desto höher die Reibungsverluste und desto geringer die erreichte Vorspannung.

So muss jede Verschraubung individuell betrachtet werden, da die im obigen Diagramm genannten Hauptgrößen je nach Schraubfall unterschiedlich gewichtet einwirken. Die „richtige“ Beurteilung erfordert viel Erfahrung und Kenntnis. Unser kompetentes Team hilft Ihnen gern bei der Auswahl des geeigneten Werkzeugs.



Wo die Kraft bleibt

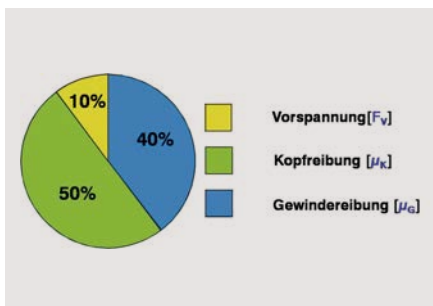

Reibverluste und Schraubfallhärte

Reibungswiderstände im Schraubengewinde (μ_G) und am Schraubenkopf (μ_k) vermindern erheblich die Umsetzung des Anzugsmoments (M₀) in Vorspannung (F_v). Sie hängen im wesentlichen vom Material, der Bearbeitung und den vorhandenen Reibflächen ab. Die Reibkräfte wirken dem Drehmoment entgegen, d. h. sie verhindern, dass ein aufgetragtes Drehmoment voll in Vorspannkraft umgesetzt werden kann.

Rund 90% des aufgetragenen Drehmoments gehen durch Reibverluste verloren:

- 50% durch Kopfreibung
- 40% durch Gewindereibung

Das bedeutet, nur 10% des aufgetragenen Drehmoments bewirken Vorspannkraft in der Schraubverbindung.

Jede Schraube kann sich, nachdem sie mit dem Kopf auf dem Werkstück aufliegt (Kopfauf- lage), um einen bestimmten Betrag drehen, bis das Enddrehmoment erreicht ist. Gemessen wird diese Drehung in Winkelgraden. Ist der Drehwinkel zwischen Kopfauf- lage und Enddrehmoment niedrig, so spricht man von einem harten Schraubfall, ist er hoch, von einem weichen Schraubfall.

Die Schraubfallhärte wird beeinflusst durch die Festigkeit der verwendeten Materialien, die Gewindesteigung, die Anzahl der Werkstücke (z.B. mehrere Blechteile) sowie die verwendeten Sicherungssysteme (z.B. Unterlegscheiben).

Drehmoment überwachen

Das direkte Messen der Vorspannkraft kann nur im Labor oder per Ultraschall erfolgen, ist also sehr aufwändig und somit kostenträchtig. Deshalb wird die Vorspannkraft in der überwiegenden Mehrzahl der Fälle über das Drehmoment (Anziehungsmoment) bestimmt. Das Drehmoment ist mit vertretbarem Aufwand im Fertigungsprozess messbar. Erfasste Drehmomentschwankungen erlauben Rückschlüsse auf:

- Bauteilveränderungen,
- Schlechtes Montagewerkzeug,
- Handhabungsfehler, etc.

Zum Überprüfen haben sich drei verschiedene Vorgehensweisen etabliert:

1. dynamisch an der Schraubstelle während der laufenden Fertigung,
2. mittels Messschlüssel an der Schraub- stelle nach der Montage, oder
3. stationär am Werkzeug während der Wartung oder Reparatur.

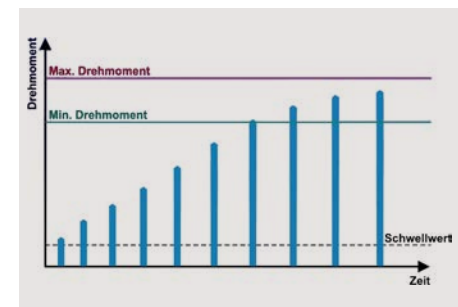

Wir bieten Ihnen auch eine reichhaltige Auswahl an hochpräziser Drehmoment-Messtechnik. Fragen Sie unsere Fachberater.





Besonderheiten der Action® Kraftsteckschlüssel



Der Vierkantantrieb

Die Kontur des Vierkants der Action® Kraftsteckschlüssel ist in den Ecken nach außen gerundet. Dadurch erhält zum einen die Antriebs-spindel des Schraubers eine ausgezeichnete Passung. Zum anderen wird dadurch das Drehmoment nicht nur in den Ecken des Kraftsteckschlüssels sondern vorwiegend an den Flanken übertragen. Dies erhöht sowohl die Lebensdauer des Kraftsteckschlüssels als auch der Antriebsspindel des Schraubers.



Der Sechskant

Abgerundete Innenecken der Action® Sechskant-Kraftsteckschlüssel bewirken ein gewisses Spiel in den Ecken des Sechskants im Schraubenkopf. Dies führt zu vergrößerter Kraftauflage an den Flanken. Außerdem bewirkt dies, dass der Verschleiß an Schraubenkopf- oder Mutterecken reduziert wird. Für Zwölfkant-Kraftsteckschlüssel gilt Ähnliches.



Surface Drive

Action® Kraftsteckschlüssel mit Surface Drive wurden entwickelt, um nur die Flankenmitte der Schraube oder Mutter anzutreiben. Der Surface-Drive ist empfohlen bei Muttern mit abgenutzten Ecken oder bei Muttern aus weicherem Material sowie bei polierten Muttern und Schrauben.

Das erleichterte „Finden“ des Steckschlüssels, der Mutter oder Schraube, ermöglicht es, mit langsam drehendem Schrauber den Steckschlüssel aufzusetzen und die Anzahl der Verschraubungen schneller auszuführen.

Bei kontinuierlich drehenden Antrieben hat das zusätzliche Spiel keinen Einfluss auf die Drehmomentgenauigkeit. Bei Impulsschraubern hingegen ist dieses zusätzliche Spiel sehr nachteilig, da es dann bei jedem Impuls zu einem Rückschlag kommt, anstatt eines kontinuierlichen Kontakts mit der Stecknuss. ‚Surface Drive‘ Steckschlüssel sollten daher **nicht für Impulsschrauber** benutzt werden.



VORSICHT!



- Schützen Sie Ihre Gesundheit. Tragen Sie Persönliche Schutzausrüstung beim Arbeiten mit Kraftwerkzeugen (Schutzbrille, Arbeitshandschuhe usw.).
- Halten Sie maschinell drehende Teile niemals mit der Hand fest!
- Wechseln Sie verschlissene Kraftsteckschlüssel frühzeitig aus.
- Gemäß EU-Direktive 2006/42/EG (Maschinenrichtlinie) und EN/ISO 11148-6 dürfen auf Motorwerkzeugen nur Kraftsteckschlüssel verwendet werden.



Der passende Biteinsatz

Bedingt durch die Größe der Bauteile oder durch das spezielle Fertigungsverfahren sind Schrauben mit Innenantrieb aus der Welt der Werkzeuge nicht wegzudenken. Das gebräuchlichste Werkzeug dafür ist der Schraubeinsatz – weltweit bekannt unter dem Kurznamen Bit (engl.: insert bit).

Der Bereich der sicherheitsrelevanten Verschraubungen nimmt ständig zu. Sei es die Schraube, die den Zugang zur Steuerung des Bremssystems nur dem autorisierten Fachmann erlauben soll. Sei es die Verbindung, welche die Demontage von Bauteilen erschweren oder verhindern soll. Solche Schrauben weisen die verschiedensten Antriebsprofile auf.

Sollten Sie einmal ein Profil benötigen, das nicht im Katalog aufgeführt ist, senden Sie uns Ihre Anfrage zu. Wir helfen Ihnen gern, das erforderliche Werkzeug zu bekommen.

Die Anforderungen an dieses Werkzeug bezüglich Standzeit und des maximal zu übertragenden Drehmoments auf die Schraube sind in den letzten Jahren enorm gestiegen. Grund für diese Anforderungen sind immer kürzere Taktzeiten und der steigende Bedarf an schnellen handgehaltenen Schraubsystemen und Schraubautomaten bei der Herstellung von Produkten. Dieser Fertigungsweg lässt unzuverlässigen Werkzeugen keine Chance mehr. Aktuell erhältliche Bits haben mit den vor 10 Jahren gefertigten Bits nicht viel mehr als die Geometrie des Abtriebs gemein.

bedeutet, man arbeitet mit einem hoch belastbaren und passgenauen Werkzeug, das ein optimales Preis-Leistungs-Verhältnis bietet.

Der positive Effekt für den Anwender ist, dass die Bits im vorliegenden Katalog bezüglich Standzeit und maximaler Drehmomentübertragung durch exakte Passform und ausgereifte Härte-technologie an der Grenze des technisch Machbaren sind. Dies

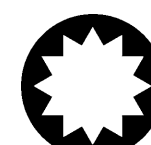
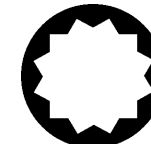
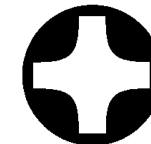

Kreuzschlitz

Das in den frühen 1930er Jahren von Henry Phillips erfundene Kreuzschlitz-Schraubenkopfprofil (PH) ist innenwärts gerundet. (Ironischerweise hat die heute existierende Phillips Screw Company noch nie PH-Schrauben oder -Schraubendreher hergestellt.)

Das Pozidriv®-Profil unterscheidet sich durch rechtwinklige „Führungsnasen“, die den Halt des Werkzeugs im Schraubenkopf verstärken.

Heute existiert eine Reihe von Variationen des Kreuzschlitz-Profiles, wie beispielsweise Phillips II®, Phillips Square-Driv® (3. Abb. v. o.) oder Pozisquare-Driv®, u.a.m.

Weniger verbreitet, aber leicht mit „PH“ verwechselbar ist der „Frearson“ Kreuzschlitz, der echte 90°-Flanken aufweist.

Zwölfkant

Das Vielzahn-Profil, auch XZN genannt, besteht aus drei gegeneinander versetzten Quadraten. Dadurch hat es außen 12 rechtwinklige Kanten. Im Englischen wird es daher „Triple Square“ (dt. Dreifach-Quadrat) genannt.

Das Doppelsechskant-Profil weist ebenfalls 12 Außenkanten auf. Es entsteht jedoch aus zwei symmetrisch versetzten Sechsecken, die zwölf „stumpfe“ Kanten (à 120°) ergeben.

Es gibt aber auch noch weitere 12-kantige Profile, wie sie z.B. aus vier versetzten Dreiecken mit spitzen Kanten (à 60°) entstehen, u.a.m.

Sechsrund

Das im Jahre 1967 von Camcar® (Textron) unter dem Markennamen Torx® entwickelte Sechsrund-Profil weist abwechselnde radial gekrümmte Vorsprünge und Auskehlungen auf. Frei von Camout-Effekt, ermöglichte es eine deutlich höhere Kraftübertragung als alle bis dahin bekannten Antriebsprofile.

Auch hier entstand im Laufe der Zeit eine Reihe von Abwandlungen und Weiterentwicklungen, wie beispielsweise Torx® Tamper Resistant, auch: Tamper Proof (kl. Abb. u.) oder Security Torx®, sowie schließlich das lange Jahre unübertroffene TorxPlus® -Profil mit annähernd echtem Null-Grad-Antriebswinkel.

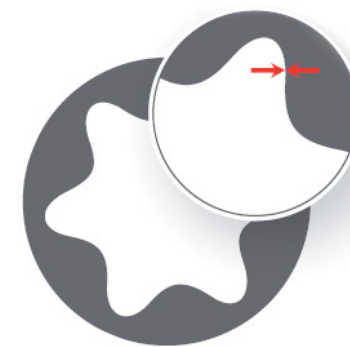

TORX®

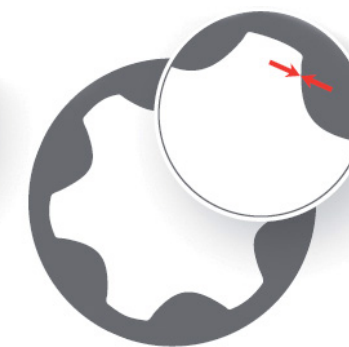

TORX PLUS®



Tamper-Resistant Torx® (TR)



Tamper-Resistant TorxPlus® (IPR)



1/4 Kraftsteckschlüssel mit 1/4" Vierkanttrieb nach DIN 3121 G 6,3



Sechskant – normal

Modell	Best.-Nr.	SW mm	L mm	D1 mm	D2 mm	L2 mm	VE
K1/4-4	210011	4	23	7,6	13	4,0	5
K1/4-4.5	210012	4,5	23	8,2	13	5,0	5
K1/4-5	210013	5	23	8,8	13	5,0	5
K1/4-5.5	210014	5,5	23	9,5	13	5,0	5
K1/4-6	210015	6	23	10,0	13	6,0	5
K1/4-7	210016	7	23	11,3	13	6,0	5
K1/4-8	210017	8	23	12,5	13	7,0	5
K1/4-9	210018	9	23	13,8	13	7,0	5
K1/4-10	210019	10	23	15,0	13	7,0	5
K1/4-11	210020	11	23	16,3	13	8,0	5
K1/4-12	210021	12	23	17,0	13	8,0	5
K1/4-13	210022	13	23	18,8	13	8,0	5
K1/4-14	210023	14	23	20,0	13	8,0	5
K1/4-15	210024	15	23	21,0	13	8,0	5



Sechskant – tief

Modell	Best.-Nr.	SW	L	D1	D2	L2	VE
K1/4-4L	210306	4	50	8,2	13	4,0	5
K1/4-4.5L	210307	4,5	50	8,2	13	6,0	5
K1/4-5L	210308	5	50	8,8	13	6,0	5
K1/4-6L	210309	6	50	10,0	13	7,0	5
K1/4-7L	210310	7	50	11,3	13	5,0	5
K1/4-8L	210311	8	50	12,5	13	5,0	5
K1/4-9L	210312	9	50	13,8	13	5,0	5
K1/4-10L	210313	10	50	15,0	13	9,0	5
K1/4-11L	210314	11	50	16,3	13	9,0	5
K1/4-12L	210315	12	50	17,0	13	9,0	5
K1/4-13L	210316	13	50	18,8	13	9,0	5
K1/4-14L	210318	14	50	20,0	13	9,0	5
K1/4-15L	210317	15	50	21,0	13	9,0	5



Sechskant – normal – Zoll

Modell	Best.-Nr.	SW Zoll	L mm	D1 mm	D2 mm	L2 mm	VE
K1/4-3/16	210050	3/16	23	8,5	13	5,0	5
K1/4-1/4	210051	1/4	23	10,3	13	6,0	5
K1/4-5/16	210052	5/16	23	12,5	13	7,0	5
K1/4-3/8	210053	3/8	23	15,0	13	7,0	5
K1/4-7/16	210054	7/16	23	16,3	13	8,0	5
K1/4-1/2	210055	1/2	23	18,8	13	8,0	5



Sechskant – mit Gelenk*

Modell	Best.-Nr.	SW mm	L mm	D1 mm	D2 mm	L2 mm	VE
KG1/4-5	210550	5	43	8,8	15	5,0	5
KG1/4-5.5	210551	5,5	43	9,5	15	6,0	5
KG1/4-6	210552	6	43	10,0	15	6,0	5
KG1/4-7	210553	7	43	11,5	15	8,0	5
KG1/4-8	210554	8	43	12,5	15	8,0	5
KG1/4-9	210555	9	43	14,0	15	8,0	5
KG1/4-10	210556	10	43	15,0	15	8,0	5
KG1/4-11	210557	11	43	16,5	15	8,0	5
KG1/4-12	210558	12	48	16,8	16	8,0	5
KG1/4-13	210559	13	48	18,8	16	8,0	5
KG1/4-14	210560	14	48	19,8	16	8,0	5
KG1/4-15	210561	15	48	20,8	16	8,0	5



Sechskant – extrahart

Modell	Best.-Nr.	SW mm	L mm	D1 mm	D2 mm	L2 mm	VE
K1/4-5.5-XH	210210	5,5	23	9,5	13	3,0	5
K1/4-6-XH	210211	6	23	10,0	13	3,0	5
K1/4-7-XH	210212	7	23	11,3	13	3,0	5
K1/4-8-XH	210213	8	23	12,5	13	3,0	5
K1/4-9-XH	210214	9	23	13,8	13	4,0	5
K1/4-10-XH	210215	10	23	15,0	13	4,0	5

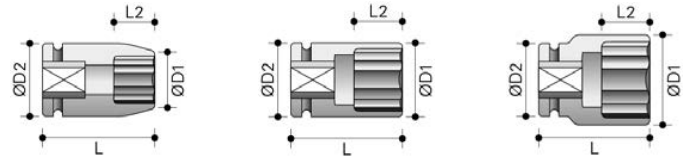

* von der Herstellergarantie ausgenommen.

Weitere Infos auf unserer Website.



1/4 Kraftsteckschlüssel mit 1/4" Vierkanttrieb nach DIN 3121 G 6,3



Surface Drive – normal

Modell	Best.-Nr.	SW mm	L mm	D1 mm	D2 mm	L2 mm	VE
K1/4-4-SD	210408	4	23	7,6	13	4,0	5
K1/4-4.5-SD	210409	4,5	23	8,2	13	5,0	5
K1/4-5-SD	210410	5	23	8,8	13	5,0	5
K1/4-5.5-SD	210411	5,5	23	9,5	13	5,0	5
K1/4-6-SD	210412	6	23	10,0	13	6,0	5
K1/4-7-SD	210413	7	23	11,3	13	6,0	5
K1/4-8-SD	210414	8	23	12,5	13	7,0	5
K1/4-9-SD	210415	9	23	13,8	13	7,0	5
K1/4-10-SD	210416	10	23	15,0	13	7,0	5
K1/4-11-SD	210417	11	23	16,3	13	8,0	5
K1/4-12-SD	210418	12	23	17,0	13	8,0	5
K1/4-13-SD	210419	13	23	18,8	13	8,0	5
K1/4-14-SD	210420	14	23	20,0	13	8,0	5
K1/4-15-SD	210421	15	23	21,0	13	8,0	5



Surface Drive – tief

Modell	Best.-Nr.	SW mm	L mm	D1 mm	D2 mm	L2 mm	VE
K1/4-4-SDL	210510	4	50	7,6	13	4,0	5
K1/4-4.5-SDL	210511	4,5	50	8,2	13	6,0	5
K1/4-5-SDL	210512	5	50	8,8	13	6,0	5
K1/4-5.5-SDL	210513	5,5	50	9,5	13	6,0	5
K1/4-6-SDL	210514	6	50	10,0	13	7,0	5
K1/4-7-SDL	210515	7	50	11,3	13	7,0	5
K1/4-8-SDL	210516	8	50	12,5	13	9,0	5
K1/4-9-SDL	210517	9	50	13,8	13	9,0	5
K1/4-10-SDL	210518	10	50	15,0	13	9,0	5
K1/4-11-SDL	210519	11	50	16,3	13	9,0	5
K1/4-12-SDL	210520	12	50	17,0	13	9,0	5
K1/4-13-SDL	210521	13	50	18,8	13	9,0	5
K1/4-14-SDL	210522	14	50	20,0	13	9,0	5
K1/4-15-SDL	210523	15	50	21,0	13	9,0	5

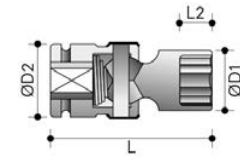

* von der Herstellergarantie ausgenommen.

Weitere Infos auf unserer Website.



Sechsrund Torx® E – normal

Modell	Best.-Nr.	SW #	L mm	D1 mm	D2 mm	L2 mm	VE
K1/4-E4	210710	E4	25	7,2	13	4,0	5
K1/4-E5	210711	E5	25	8,0	13	4,5	5
K1/4-E6	210712	E6	25	9,0	13	5,0	5
K1/4-E7	210713	E7	25	9,5	13	6,0	5
K1/4-E8	210714	E8	25	10,0	13	6,0	5
K1/4-E10	210715	E10	25	12,5	13	7,5	5
K1/4-E11	210716	E11	25	13,0	13	8,0	5
K1/4-E12	210717	E12	25	14,5	14,5	8,5	5



Sechsrund Torx® E – dünnwandig*

Modell	Best.-Nr.	SW #	L mm	D1 mm	D2 mm	L2 mm	VE
K1/4-E4-DW	210810	E4	25	6,5	13	4,0	5
K1/4-E5-DW	210811	E5	25	7,5	13	4,5	5
K1/4-E6-DW	210812	E6	25	8,5	13	5,0	5
K1/4-E7-DW	210813	E7	25	9,0	13	6,0	5
K1/4-E8-DW	210814	E8	25	9,8	13	6,0	5
K1/4-E10-DW	210815	E10	25	12,0	13	6,5	5
K1/4-E11-DW	210816	E11	25	12,7	13	8,0	5
K1/4-E12-DW	210817	E12	25	14,0	14,5	8,5	5

1/4 Kraftsteckschlüssel mit 1/4" Vierkantantrieb nach DIN 3121 G 6,3



Innensechskant Inbus® – normal

Modell	Best.-Nr.	SW mm	L mm	D1 mm	D2 mm	L1 mm	VE
K1/4-A2.5	210730	2,5	35	-	13	4,0	5
K1/4-A3	210731	3	35	-	13	6,0	5
K1/4-A4	210732	4	35	-	13	6,0	5
K1/4-A5	210733	5	35	-	13	6,0	5
K1/4-A6	210734	6	35	-	13	8,0	5
K1/4-A7	210735	7	35	-	13	8,0	5
K1/4-A8	210736	8	35	-	13	8,0	5
K1/4-A9	210737	9	35	-	13	10	5
K1/4-A10	210738	10	35	-	13	10	5



Gummiring & Sicherungsstift

Modell	Best.-Nr.	Größe Zoll	-	D1 mm	D2 mm	-	VE
RS-1/4	210950	1/4	-	-	13	-	5



Innensechsrund Torx® TX – normal

Modell	Best.-Nr.	SW #	L mm	D1 mm	D2 mm	L1 mm	VE
K1/4-T5	210850	T5	35	-	13	2,0	5
K1/4-T6	210851	T6	35	-	13	2,0	5
K1/4-T7	210852	T7	35	-	13	2,0	5
K1/4-T8	210853	T8	35	-	13	2,0	5
K1/4-T9	210854	T9	35	-	13	2,0	5
K1/4-T10	210855	T10	35	-	13	2,8	5
K1/4-T15	210856	T15	35	-	13	2,8	5
K1/4-T20	210857	T20	35	-	13	2,8	5
K1/4-T25	210858	T25	35	-	13	3,0	5
K1/4-T27	210859	T27	35	-	13	3,0	5
K1/4-T30	210860	T30	35	-	13	3,8	5

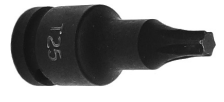

Innensechsrund Torx® TR (Tamper Resistant)

Modell	Best.-Nr.	SW #	L mm	D1 mm	D2 mm	L1 mm	VE
K1/4-TR8	210913	TR 8	35	-	13	2,0	5
K1/4-TR9	210914	TR 9	35	-	13	2,0	5
K1/4-TR10	210915	TR 10	35	-	13	2,8	5
K1/4-TR15	210916	TR 15	35	-	13	2,8	5
K1/4-TR20	210917	TR 20	35	-	13	2,8	5
K1/4-TR25	210918	TR 25	35	-	13	3,0	5
K1/4-TR27	210919	TR 27	35	-	13	3,0	5
K1/4-TR30	210920	TR 30	35	-	13	3,8	5

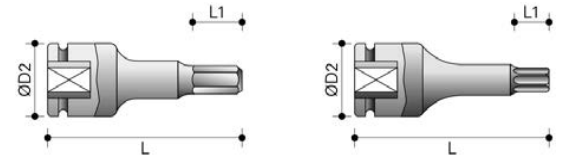

1/4 Kraftsteckschlüssel mit 1/4" Vierkantantrieb nach DIN 3121 G 6,3



Sechskant mit Magnet – normal

Modell	Best.-Nr.	SW mm	L mm	D1 mm	D2 mm	L2 mm	VE
KM1/4-5	210110	5	23	8,8	13	3,0	5
KM1/4-5.5	210111	5,5	23	9,5	13	3,0	5
KM1/4-6	210112	6	23	10,0	13	3,0	5
KM1/4-7	210113	7	23	11,3	13	3,0	5
KM1/4-8	210114	8	23	12,5	13	3,0	5
KM1/4-9	210115	9	23	13,8	13	4,0	5
KM1/4-10	210116	10	23	15,0	13	4,0	5
KM1/4-11	210117	11	23	16,3	13	5,0	5
KM1/4-12	210118	12	23	17,0	13	5,0	5
KM1/4-13	210119	13	23	18,8	13	5,0	5
KM1/4-14	210120	14	23	20,0	13	6,0	5
KM1/4-15	210121	15	23	21,0	13	6,0	5



Sechskant mit Magnet – extrahart

Modell	Best.-Nr.	SW mm	L mm	D1 mm	D2 mm	L2 mm	VE
KM1/4-5-XH	210249	5	23	-	13	3,0	5
KM1/4-5.5-XH	210250	5,5	23	10,0	13	3,0	5
KM1/4-7-XH	210252	7	23	12,5	13	3,0	5
KM1/4-8-XH	210253	8	23	13,8	13	4,0	5
KM1/4-9-XH	210254	9	23	15,0	13	4,0	5
KM1/4-10-XH	210255	10	23	16,3	13	5,0	5
KM1/4-11-XH	210256	11	23	-	13	5,0	5
KM1/4-13-XH	210258	13	23	-	13	5,0	5



Sechskant mit Magnet – Zoll

Modell	Best.-Nr.	SW Zoll	L mm	D1 mm	D2 mm	L2 mm	VE
KM1/4-1/4	210150	1/4	23	11,3	13	3,0	5
KM1/4-5/16	210151	5/16	23	13,2	13	3,0	5
KM1/4-3/8	210152	3/8	23	16,0	13	3,0	5
KM1/4-1/2	210153	1/2	23	18,0	13	4,0	5

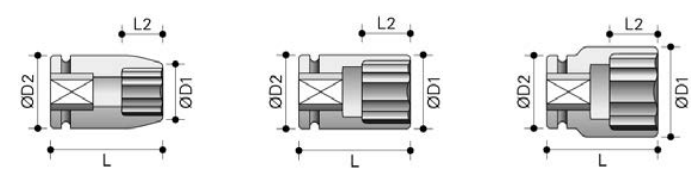

Sechskant mit Magnet – tief

Modell	Best.-Nr.	SW mm	L mm	D1 mm	D2 mm	L2 mm	VE
KM1/4-5L	210346	5	50	8,8	13	3,0	5
KM1/4-5.5L	210347	5,5	50	9,5	13	3,0	5
KM1/4-6L	210349	6	50	10,0	13	3,0	5
KM1/4-7L	210350	7	50	11,3	13	3,0	5
KM1/4-8L	210351	8	50	12,5	13	3,0	5
KM1/4-9L	210352	9	50	13,8	13	4,0	5
KM1/4-10L	210353	10	50	15,0	13	4,0	5
KM1/4-11L	210354	11	50	16,3	13	5,0	5
KM1/4-12L	210355	12	50	17,0	13	5,0	5
KM1/4-13L	210356	13	50	18,8	13	5,0	5
KM1/4-14L	210357	14	50	20,0	13	6,0	5
KM1/4-15L	210358	15	50	21,0	13	6,0	5



Surface Drive mit Magnet – normal

Modell	Best.-Nr.	SW mm	L mm	D1 mm	D2 mm	L2 mm	VE
KM1/4-7-SD	210450	7	23	11,3	13	3,0	5
KM1/4-8-SD	210451	8	23	12,5	13	3,5	5
KM1/4-10-SD	210453	10	23	15,0	13	4,2	5
KM1/4-13-SD	210455	13	23	18,8	13	6,0	5



Sechsrund Torx® E mit Magnet – normal

Modell	Best.-Nr.	SW #	L mm	D1 mm	D2 mm	L2 mm	VE
KM1/4-E6	210750	E6	25	8,5	13	5,0	5
KM1/4-E8	210751	E8	25	9,8	13	6,0	5
KM1/4-E10	210752	E10	25	12,0	13	7,5	5
KM1/4-E12	210753	E12	25	14,0	13	8,5	5



3/8 Kraftsteckschlüssel mit 3/8" Vierkantantrieb nach DIN 3121 G 10



Sechskant – normal

Modell	Best.-Nr.	SW mm	L mm	D1 mm	D2 mm	L2 mm	VE
K3/8-6	220050	6	30	11,0	19	4,0	5
K3/8-7	220051	7	30	12,5	19	8,0	5
K3/8-8	220052	8	30	14,0	19	8,0	5
K3/8-9	220053	9	30	15,0	19	8,0	5
K3/8-10	220054	10	30	16,0	19	8,0	5
K3/8-11	220055	11	30	17,5	19	9,0	5
K3/8-12	220056	12	30	19,0	19	9,0	5
K3/8-13	220057	13	30	20,0	22	9,0	5
K3/8-14	220058	14	30	21,0	22	9,0	5
K3/8-15	220059	15	30	22,0	22	11,0	5
K3/8-16	220060	16	30	24,0	22	11,0	5
K3/8-17	220061	17	30	25,0	22	11,0	5
K3/8-18	220062	18	30	26,0	22	11,0	5
K3/8-19	220063	19	30	27,5	22	11,0	5
K3/8-20	220064	20	30	28,0	22	12,0	5
K3/8-21	220065	21	30	30,0	22	13,0	5
K3/8-22	220066	22	30	32,0	23	13,0	5
K3/8-24	220067	24	30	34,0	23	13,0	5

Sechskant – tief

Modell	Best.-Nr.	SW mm	L mm	D1 mm	D2 mm	L2 mm	VE
K3/8-6-L	220209	6	65	11,0	19	12,0	5
K3/8-7-L	220210	7	65	12,5	19	12,0	5
K3/8-8-L	220211	8	65	13,8	19	12,0	5
K3/8-9-L	220212	9	65	15,0	19	12,0	5
K3/8-10-L	220213	10	65	16,0	19	12,0	5
K3/8-11-L	220214	11	65	17,5	19	25,0	5
K3/8-12-L	220215	12	65	19,0	19	25,0	5
K3/8-13-L	220216	13	65	20,0	22	25,0	5
K3/8-14-L	220217	14	65	21,0	22	25,0	5
K3/8-15-L	220218	15	65	22,0	22	25,0	5
K3/8-16-L	220219	16	65	24,0	22	25,0	5
K3/8-17-L	220220	17	65	25,0	22	25,0	5
K3/8-18-L	220221	18	65	26,0	22	25,0	5
K3/8-19-L	220222	19	65	27,5	22	25,0	5
K3/8-20-L	220223	20	65	28,0	22	25,0	5
K3/8-21-L	220224	21	65	30,0	22	25,0	5
K3/8-22-L	220225	22	65	32,0	23	25,0	5
K3/8-24-L	220226	24	65	34,0	23	25,0	5

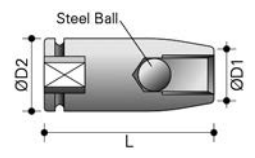

Sechskant – normal – Zoll

Modell	Best.-Nr.	SW Zoll	L mm	D1 mm	D2 mm	L2 mm	VE
K3/8-5/16	220080	5/16	30	12,5	19	8,0	5
K3/8-3/8	220081	3/8	30	14,5	19	8,0	5
K3/8-7/16	220082	7/16	30	17,0	19	9,0	5
K3/8-1/2	220083	1/2	30	19,0	22	9,0	5
K3/8-9/16	220084	9/16	30	20,0	20	9,0	5
K3/8-5/8	220085	5/8	30	24,0	24	11,0	5
K3/8-11/16	220086	11/16	30	24,0	24	11,0	5

Stehbolzensetzer

Modell	Best.-Nr.	Gewinde	D1 mm	D2 mm	L mm	VE
SB3/8-M5-0.8	222150	M5 × 0.8	12	22	50	
SB3/8-M6-1.0	222153	M6 × 1.0	12.5	22	50	
SB3/8-M7-1.0	222156	M7 × 1.0	13	22	50	
SB3/8-M8-1.0	222159	M8 × 1.0	15	22	50	
SB3/8-M8-1.25	222160	M8 × 1.25	14.5	22	50	
SB3/8-M10-1.25	222162	M10 × 1.25	18	22	50	
SB3/8-M10-1.5	222163	M10 × 1.5	17	22	50	
SB3/8-M12-1.75	222166	M12 × 1.75	19	22	50	

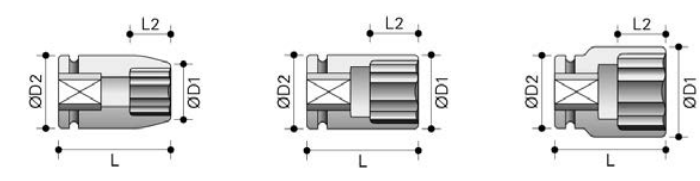

3/8 Kraftsteckschlüssel mit 3/8" Vierkantantrieb nach DIN 3121 G 10



Sechskant – XL & XXL

Modell	Best.-Nr.	SW mm	L mm	D1 mm	D2 mm	L2 mm	VE
K3/8-6-150	220310	6	150	11,0	19	4,0	-
K3/8-8-150	220311	8	150	13,0	19	8,0	-
K3/8-10-150	220312	10	150	16,0	19	8,0	-
K3/8-12-150	220313	12	150	18,5	19	9,0	-
K3/8-13-150	220314	13	150	20,0	22	9,0	-
K3/8-14-150	220315	14	150	21,0	22	9,0	-
K3/8-15-150	220316	15	150	22,0	22	11,0	-
K3/8-16-150	220317	16	150	24,0	22	11,0	-
K3/8-17-150	220318	17	150	25,0	22	11,0	-
K3/8-18-150	220319	18	150	26,0	22	12,0	-
K3/8-6-200	220350	6	200	11,0	19	4,0	-
K3/8-8-200	220351	8	200	13,0	19	8,0	-
K3/8-10-200	220352	10	200	16,0	19	8,0	-
K3/8-12-200	220353	12	200	18,5	19	9,0	-
K3/8-13-200	220354	13	200	20,0	22	9,0	-
K3/8-14-200	220355	14	200	21,0	22	9,0	-
K3/8-15-200	220356	15	200	22,0	22	11,0	-
K3/8-16-200	220357	16	200	24,0	22	11,0	-
K3/8-17-200	220358	17	200	25,0	22	11,0	-
K3/8-6-250	220410	6	250	11,0	19	4,0	-
K3/8-8-250	220411	8	250	13,0	19	8,0	-
K3/8-10-250	220412	10	250	16,0	19	8,0	-
K3/8-12-250	220413	12	250	18,5	19	9,0	-
K3/8-13-250	220414	13	250	20,0	22	9,0	-
K3/8-14-250	220415	14	250	21,0	22	9,0	-
K3/8-15-250	220416	15	250	22,0	22	11,0	-
K3/8-16-250	220417	16	250	24,0	22	11,0	-
K3/8-17-250	220418	17	250	25,0	22	11,0	-

Sechskant – mit Gelenk* – normal

Modell	Best.-Nr.	SW mm	L mm	D1 mm	D2 mm	L2 mm	VE
KG3/8-9-K	220750	9	53	15,0	24	9,0	-
KG3/8-10-K	220751	10	53	15,0	24	9,0	-
KG3/8-11-K	220752	11	53	17,0	24	9,0	-
KG3/8-12-K	220753	12	53	19,0	24	12,0	-
KG3/8-13-K	220754	13	53	19,0	24	13,0	-
KG3/8-14-K	220755	14	53	21,0	24	13,0	-
KG3/8-15-K	220756	15	53	22,0	24	13,0	-
KG3/8-16-K	220757	16	53	23,0	24	13,0	-
KG3/8-17-K	220758	17	53	25,0	24	13,0	-
KG3/8-18-K	220759	18	53	25,0	24	13,0	-
KG3/8-19-K	220760	19	53	27,0	24	13,0	-
KG3/8-20-K	220761	20	53	30,0	24	13,0	-
KG3/8-21-K	220762	21	53	30,0	24	13,0	-
KG3/8-22-K	220763	22	53	32,0	24	13,0	-



Sechskant – mit Gelenk* – tief

Modell	Best.-Nr.	SW mm	L mm	D1 mm	D2 mm	L2 mm	VE
KG3/8-9	220810	9	78	15,0	24	20,0	-
KG3/8-10	220811	10	78	15,0	24	20,0	-
KG3/8-11	220812	11	80	17,0	24	20,0	-
KG3/8-12	220813	12	80	19,0	24	20,0	-
KG3/8-13	220814	13	80	19,0	24	20,0	-
KG3/8-14	220815	14	80	21,0	24	20,0	-
KG3/8-15	220816	15	80	22,0	24	20,0	-
KG3/8-16	220817	16	80	23,0	24	20,0	-
KG3/8-17	220818	17	80	25,0	24	20,0	-
KG3/8-18	220819	18	80	25,0	24	20,0	-
KG3/8-19	220820	19	80	27,0	24	25,0	-
KG3/8-20	220821	20	80	30,0	24	25,0	-
KG3/8-21	220822	21	80	30,0	24	25,0	-
KG3/8-22	220823	22	80	32,0	24	25,0	-



Sechskant – mit Gelenk* – XL

Modell	Best.-Nr.	SW mm	L mm	D1 mm	D2 mm	L2 mm	VE
KG3/8-10-EL	220910	10	150	14,3	19	7,0	-
KG3/8-12-EL	220912	12	150	18,0	19	8,0	-
KG3/8-13-EL	220913	13	150	19,3	19	8,5	-

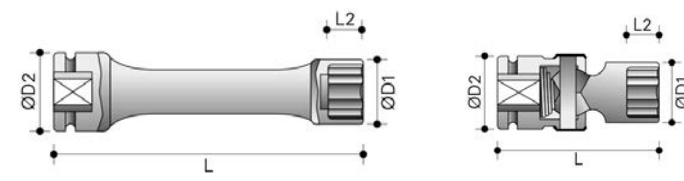

3/8 Kraftsteckschlüssel mit 3/8" Vierkantantrieb nach DIN 3121 G 10



Sechskant – dünnwandig* – normal

Modell	Best.-Nr.	SW mm	L mm	D1 mm	D2 mm	L2 mm	VE
K3/8-6-DW	220948	6	30	10,5	19,0	4,0	5
K3/8-7-DW	220949	7	30	11,5	19,0	8,0	5
K3/8-8-DW	220950	8	30	12,3	18,5	5,0	5
K3/8-9-DW	220951	9	30	13,5	18,5	6,0	5
K3/8-10-DW	220952	10	30	14,8	18,5	6,0	5
K3/8-11-DW	220953	11	30	16,0	18,5	7,0	5
K3/8-12-DW	220954	12	30	17,3	18,5	8,0	5
K3/8-13-DW	220955	13	30	18,5	21,5	10,0	5
K3/8-14-DW	220956	14	30	19,8	21,5	10,0	5



Surface Drive – normal

Modell	Best.-Nr.	SW mm	L mm	D1 mm	D2 mm	L2 mm	VE
K3/8-8-SD	220450	8	32	13,8	19	8,0	5
K3/8-9-SD	220451	9	32	15,0	19	8,0	5
K3/8-10-SD	220452	10	32	16,0	19	8,0	5
K3/8-11-SD	220453	11	32	17,5	19	9,0	5
K3/8-12-SD	220454	12	32	19,0	19	9,0	5
K3/8-13-SD	220455	13	32	20,0	22	9,0	5
K3/8-14-SD	220456	14	32	22,0	22	9,0	5
K3/8-15-SD	220457	15	32	22,0	22	11,0	5
K3/8-16-SD	220458	16	32	24,0	22	11,0	5
K3/8-17-SD	220459	17	32	25,0	22	11,0	5
K3/8-18-SD	220460	18	32	26,0	22	11,0	5
K3/8-19-SD	220461	19	32	28,0	22	11,0	5



Surface Drive – normal – Zoll

Modell	Best.-Nr.	SW Zoll	L mm	D1 mm	D2 mm	L2 mm	VE
K3/8-1/4-SD	220510	1/4	32	11,5	19	4,0	5
K3/8-5/16-SD	220511	5/16	32	13,8	19	8,0	5
K3/8-3/8-SD	220512	3/8	32	15,5	19	8,0	5
K3/8-7/16-SD	220513	7/16	32	17,5	19	9,0	5
K3/8-1/2-SD	220514	1/2	32	20,0	22	9,0	5
K3/8-9/16-SD	220515	9/16	32	22,0	22	11,0	5
K3/8-5/8-SD	220516	5/8	32	24,0	22	11,0	5
K3/8-11/16-SD	220517	11/16	32	26,0	22	11,0	5
K3/8-3/4-SD	220518	3/4	32	28,0	22	11,0	5



Sechskant – dünnwandig* – tief

Modell	Best.-Nr.	SW mm	L mm	D1 mm	D2 mm	L2 mm	VE
K3/8-7-DWL	221010	7	65	11,5	19	12,0	5
K3/8-8-DWL	221011	8	65	12,5	19	12,0	5
K3/8-9-DWL	221012	9	65	14,0	19	12,0	5
K3/8-10-DWL	221013	10	65	15,0	19	25,0	5
K3/8-11-DWL	221014	11	65	17,0	19	25,0	5
K3/8-12-DWL	221015	12	65	17,5	19	25,0	5
K3/8-13-DWL	221016	13	65	19,0	19	25,0	5
K3/8-14-DWL	221017	14	65	20,0	20	25,0	5
K3/8-15-DWL	221018	15	65	21,0	22	25,0	5
K3/8-16-DWL	221019	16	65	22,5	22	25,0	5
K3/8-17-DWL	221020	17	65	24,0	22	25,0	5
K3/8-18-DWL	221021	18	65	25,0	22	25,0	5
K3/8-19-DWL	221022	19	65	26,0	22	25,0	5
K3/8-20-DWL	221023	20	65	27,0	22	25,0	5
K3/8-21-DWL	221024	21	65	28,0	22	25,0	5
K3/8-22-DWL	221025	22	65	30,0	23	25,0	5



Sechskant Fast Lead – normal

Modell	Best.-Nr.	SW mm	L mm	D1 mm	D2 mm	L2 mm	VE
K3/8-10-FL	220710	10	32	15,8	19	8,0	5
K3/8-11-FL	220711	11	32	17,0	19	8,0	5
K3/8-12-FL	220712	12	32	18,3	19	9,0	5
K3/8-13-FL	220713	13	32	19,5	22	9,0	5
K3/8-14-FL	220714	14	32	20,8	22	11,0	5
K3/8-15-FL	220715	15	32	22,0	22	11,0	5
K3/8-16-FL	220716	16	32	23,3	22	11,0	5
K3/8-17-FL	220717	17	32	24,5	22	12,0	5
K3/8-18-FL	220718	18	32	25,8	22	13,0	5
K3/8-19-FL	220719	19	32	27,0	22	13,0	5

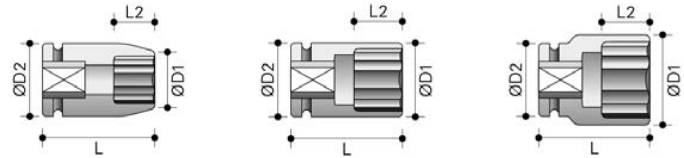

* von der Herstellergarantie ausgenommen.
 Weitere Infos auf unserer Website.

3/8 Kraftsteckschlüssel mit 3/8" Vierkantantrieb nach DIN 3121 G 10



Surface Drive – tief

Modell	Best.-Nr.	SW mm	L mm	D1 mm	D2 mm	L2 mm	VE
K3/8-8-SDL	220610	8	80	13,8	19	12,0	-
K3/8-9-SDL	220611	9	80	15,0	19	12,0	-
K3/8-10-SDL	220612	10	80	16,0	19	12,0	-
K3/8-11-SDL	220613	11	80	17,5	19	25,0	-
K3/8-12-SDL	220614	12	80	19,0	19	25,0	-
K3/8-13-SDL	220615	13	80	20,0	22	25,0	-
K3/8-14-SDL	220616	14	80	22,0	22	25,0	-
K3/8-15-SDL	220617	15	80	22,0	22	25,0	-
K3/8-16-SDL	220618	16	80	24,0	22	25,0	-
K3/8-17-SDL	220619	17	80	25,0	22	25,0	-
K3/8-18-SDL	220620	18	80	26,0	22	25,0	-
K3/8-19-SDL	220621	19	80	28,0	22	25,0	-



Surface Drive – tief – Zoll

Modell	Best.-Nr.	SW Zoll	L mm	D1 mm	D2 mm	L2 mm	VE
K3/8-5/16-SDL	220650	5/16	80	13,8	19	12,0	-
K3/8-3/8-SDL	220651	3/8	80	15,5	19	12,0	-
K3/8-7/16-SDL	220652	7/16	80	17,5	19	25,0	-
K3/8-1/2-SDL	220653	1/2	80	20,0	22	25,0	-
K3/8-9/16-SDL	220654	9/16	80	22,0	22	25,0	-
K3/8-5/8-SDL	220655	5/8	80	24,0	22	25,0	-
K3/8-11/16-SDL	220656	11/16	80	26,0	22	25,0	-
K3/8-3/4-SDL	220657	3/4	80	28,0	22	25,0	-

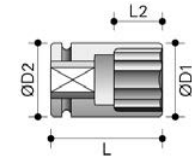

* von der Herstellergarantie ausgenommen.
 Weitere Infos auf unserer Website.



Surface Drive – dünnwandig* – tief

Modell	Best.-Nr.	SW mm	L mm	D1 mm	D2 mm	L2 mm	VE
K3/8-8-DWSDL	221150	8	65	12,3	18,5	7,0	5
K3/8-9-DWSDL	221151	9	65	13,5	18,5	9,0	5
K3/8-10-DWSDL	221152	10	65	14,8	18,5	9,0	5
K3/8-11-DWSDL	221153	11	65	16,0	18,5	10,5	5
K3/8-12-DWSDL	221154	12	65	17,3	18,5	12,0	5
K3/8-13-DWSDL	221155	13	65	18,5	21,5	12,0	5
K3/8-15-DWSDL	221157	15	65	21,0	21,5	15,0	5
K3/8-16-DWSDL	221158	16	65	22,3	21,5	15,0	5
K3/8-17-DWSDL	221159	17	65	23,5	21,5	15,0	5
K3/8-18-DWSDL	221160	18	65	24,8	21,5	18,0	5
K3/8-19-DWSDL	221161	19	65	26,0	21,5	18,0	5



Doppelsechskant – normal

Modell	Best.-Nr.	SW mm	L mm	D1 mm	D2 mm	L2 mm	VE
K3/8-6-DSK	221210	6	30	11,0	19	5,0	5
K3/8-7-DSK	221211	7	30	12,0	19	8,0	5
K3/8-8-DSK	221212	8	30	13,0	19	8,0	5
K3/8-9-DSK	221213	9	30	15,0	19	8,0	5
K3/8-10-DSK	221214	10	30	16,0	19	8,0	5
K3/8-11-DSK	221215	11	30	17,5	19	9,0	5
K3/8-12-DSK	221216	12	30	18,5	19	9,0	5
K3/8-13-DSK	221217	13	30	20,0	22	10,0	5
K3/8-14-DSK	221218	14	30	21,0	22	11,0	5
K3/8-15-DSK	221219	15	30	22,0	22	12,0	5
K3/8-16-DSK	221220	16	30	24,0	22	12,0	5
K3/8-17-DSK	221221	17	30	25,0	22	12,0	5
K3/8-18-DSK	221222	18	30	26,0	22	13,0	5
K3/8-19-DSK	221223	19	30	27,0	22	13,0	5
K3/8-20-DSK	221224	20	30	28,0	22	13,0	5
K3/8-21-DSK	221225	21	30	30,0	22	14,0	5
K3/8-22-DSK	221226	22	30	31,0	23	15,0	5
K3/8-23-DSK	221227	23	30	32,0	23	15,0	5
K3/8-24-DSK	221228	24	30	34,0	23	16,0	5
K3/8-25-DSK	221229	25	30	35,0	23	16,0	5
K3/8-26-DSK	221230	26	30	36,0	23	16,0	5

3/8 Kraftsteckschlüssel mit 3/8" Vierkantantrieb nach DIN 3121 G 10



Doppelsechskant – tief

Modell	Best.-Nr.	SW mm	L mm	D1 mm	D2 mm	L2 mm	VE
K3/8-6-DSKL	221250	6	63	11,0	19	5,0	5
K3/8-7-DSKL	221251	7	63	12,0	19	12,0	5
K3/8-8-DSKL	221252	8	63	13,0	19	12,0	5
K3/8-9-DSKL	221253	9	65	15,0	19	12,0	5
K3/8-10-DSKL	221254	10	65	16,0	19	22,0	5
K3/8-11-DSKL	221255	11	65	17,5	19	22,0	5
K3/8-12-DSKL	221256	12	65	18,5	19	22,0	5
K3/8-13-DSKL	221257	13	65	20,0	22	22,0	5
K3/8-14-DSKL	221258	14	65	21,0	22	22,0	5
K3/8-15-DSKL	221259	15	65	22,0	22	22,0	5
K3/8-16-DSKL	221260	16	65	24,0	22	24,0	5
K3/8-17-DSKL	221261	17	65	25,0	22	24,0	5
K3/8-18-DSKL	221262	18	65	26,0	22	24,0	5
K3/8-19-DSKL	221263	19	65	27,0	22	24,0	5
K3/8-20-DSKL	221264	20	65	28,0	22	24,0	5
K3/8-21-DSKL	221265	21	65	30,0	22	24,0	5
K3/8-22-DSKL	221266	22	65	31,0	23	24,0	5
K3/8-23-DSKL	221267	23	65	32,0	23	24,0	5
K3/8-24-DSKL	221268	24	65	34,0	23	24,0	5
K3/8-25-DSKL	221269	25	65	35,0	23	24,0	5
K3/8-26-DSKL	221270	26	65	36,0	23	24,0	5



Sechsrund Torx® – normal

Modell	Best.-Nr.	SW #	L mm	D1 mm	D2 mm	L2 mm	VE
K3/8-E5	221510	E5	32	9,0	19	4,5	5
K3/8-E6	221511	E6	32	10,0	19	5,0	5
K3/8-E7	221512	E7	32	10,0	19	6,0	5
K3/8-E8	221513	E8	32	10,5	19	6,0	5
K3/8-E10	221514	E10	32	12,5	19	7,5	5
K3/8-E11	221515	E11	32	14,5	19	8,0	5
K3/8-E12	221516	E12	32	15,0	19	8,5	5
K3/8-E14	221517	E14	32	17,5	19	10,0	5
K3/8-E16	221518	E16	32	19,0	19	11,0	5
K3/8-E18	221519	E18	34	21,0	21	12,5	5



Sechsrund Torx® E – dünnwandig*

Modell	Best.-Nr.	SW #	L mm	D1 mm	D2 mm	L2 mm	VE
K3/8-E5-DW	221610	E5	32	8,0	19	4,5	5
K3/8-E6-DW	221611	E6	32	9,0	19	5,0	5
K3/8-E7-DW	221612	E7	32	9,3	19	6,0	5
K3/8-E8-DW	221613	E8	32	10,0	19	6,0	5
K3/8-E10-DW	221614	E10	32	12,3	19	7,5	5
K3/8-E11-DW	221615	E11	32	13,0	19	8,0	5
K3/8-E12-DW	221616	E12	32	14,0	19	8,5	5
K3/8-E14-DW	221617	E14	32	16,5	19	10,0	5
K3/8-E16-DW	221618	E16	32	18,4	19	11,0	5



Sechsrund Torx® E – mit Gelenk*

Modell	Best.-Nr.	SW #	L mm	D1 mm	D2 mm	L2 mm	VE
KG3/8-E5	221550	E5	50	-	24	4,5	5
KG3/8-E6	221551	E6	50	-	24	5,0	5
KG3/8-E7	221552	E7	50	-	24	6,0	5
KG3/8-E8	221553	E8	50	-	24	6,0	5
KG3/8-E10	221554	E10	50	-	24	7,5	5
KG3/8-E12	221555	E12	50	-	24	8,5	5
KG3/8-E14	221556	E14	50	-	24	10,0	5
KG3/8-E16	221557	E16	50	-	24	11,0	5

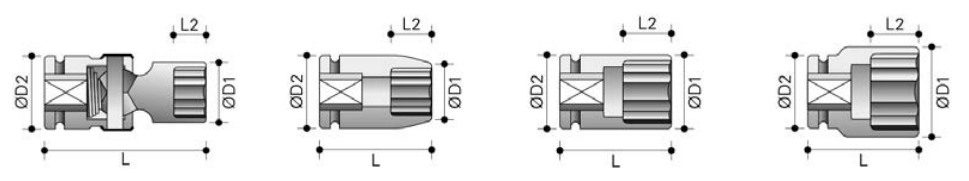

* von der Herstellergarantie ausgenommen.

Weitere Infos auf unserer Website.

24/7

3/8 Kraftsteckschlüssel mit 3/8" Vierkantantrieb nach DIN 3121 G 10



Innensechskant Inbus® – normal

Modell	Best.-Nr.	SW mm	L mm	D1 mm	D2 mm	L1 mm	VE
K3/8-A3	221310	3	50	-	19	16	5
K3/8-A4	221311	4	50	-	19	16	5
K3/8-A5	221312	5	50	-	19	16	5
K3/8-A6	221313	6	50	-	19	16	5
K3/8-A7	221314	7	50	-	19	16	5
K3/8-A8	221315	8	50	-	19	16	5
K3/8-A9	221316	9	50	-	19	16	5
K3/8-A10	221317	10	50	-	19	16	5
K3/8-A11	221318	11	50	-	19	16	5
K3/8-A12	221319	12	50	-	19	16	5
K3/8-A13	221320	13	50	-	19	16	5
K3/8-A14	221321	14	50	-	19	16	5
K3/8-A15	221322	15	50	-	19	16	5
K3/8-A16	221323	16	50	-	19	16	5



Innensechskant Inbus® – tief

Modell	Best.-Nr.	SW mm	L mm	D1 mm	D2 mm	L1 mm	VE
K3/8-A3L	221330	3	150	-	19	16	5
K3/8-A4L	221331	4	150	-	19	16	5
K3/8-A5L	221332	5	150	-	19	16	5
K3/8-A6L	221333	6	150	-	19	16	5
K3/8-A7L	221334	7	150	-	19	16	5
K3/8-A8L	221335	8	150	-	19	16	5
K3/8-A9L	221336	9	150	-	19	16	5
K3/8-A10L	221337	10	150	-	19	16	5
K3/8-A11L	221338	11	150	-	19	16	5
K3/8-A12L	221339	12	150	-	19	16	5
K3/8-A13L	221340	13	150	-	19	16	5
K3/8-A14L	221341	14	150	-	19	16	5
K3/8-A15L	221342	15	150	-	19	16	5
K3/8-A16L	221343	16	150	-	19	16	5

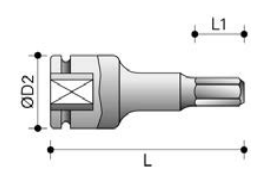

* von der Herstellergarantie ausgenommen.

Weitere Infos auf unserer Website.

24/7



Innensechskant Inbus® – mit Gelenk*

Modell	Best.-Nr.	SW mm	L mm	D1 mm	D2 mm	L1 mm	VE
KG3/8-A5	221350	5	60	-	24	11	5
KG3/8-A6	221351	6	60	-	24	11	5
KG3/8-A7	221352	7	60	-	24	15	5
KG3/8-A8	221353	8	60	-	24	15	5
KG3/8-A9	221354	9	60	-	24	15	5
KG3/8-A10	221355	10	60	-	24	15	5
KG3/8-A11	221356	11	60	-	24	15	5
KG3/8-A12	221357	12	60	-	24	15	5
KG3/8-A13	221358	13	60	-	24	15	5
KG3/8-A14	221359	14	60	-	24	15	5
KG3/8-A15	221360	15	60	-	24	15	5
KG3/8-A16	221361	16	60	-	24	15	5



Halter & auswechselbare Einsätze

Modell	Best.-Nr.	SW	L mm	D1 mm	D2 mm	T mm	VE
K3/8-AWE7/16	221410	7/16	32	22,0	22	-	-
AWE7/16-A5	221450	5	35	-	-	-	5
AWE7/16-A6	221451	6	35	-	-	-	5
AWE7/16-A8	221452	8	35	-	-	-	5
AWE7/16-A10	221453	10	35	-	-	-	5
AWE7/16-A12	221454	12	35	-	-	-	5
AWE7/16-A14	221455	14	35	-	-	-	5
AWE7/16-A17	221456	17	35	-	-	-	5

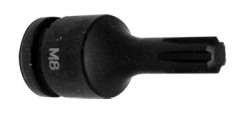

Innensechskant RIBE® – normal

Modell	Best.-Nr.	SW #	L mm	D1 mm	D2 mm	L1 mm	VE
K3/8-R5	221830	R5	50	-	19	4,5	5
K3/8-R6	221831	R6	50	-	19	5,0	5
K3/8-R7	221832	R7	50	-	19	6,5	5
K3/8-R8	221833	R8	50	-	19	7,5	5
K3/8-R10	221834	R10	50	-	19	9,0	5
K3/8-R12	221835	R12	50	-	19	10,0	5
K3/8-R14	221836	R14	50	-	19	12,0	5
K3/8-R16	221837	R16	50	-	19	14,0	5

3/8 Kraftsteckschlüssel mit 3/8" Vierkantantrieb nach DIN 3121 G 10



Innensechsrund Torx® TX – normal ¹⁾

Modell	Best.-Nr.	SW #	L mm	D1 mm	D2 mm	L1 mm	VE
K3/8-T9	221650	T9	50	-	19	2,8	5
K3/8-T10	221651	T10	50	-	19	2,8	5
K3/8-T15	221652	T15	50	-	19	2,8	5
K3/8-T20	221653	T20	50	-	19	3,0	5
K3/8-T25	221654	T25	50	-	19	3,0	5
K3/8-T27	221655	T27	50	-	19	3,8	5
K3/8-T30	221656	T30	50	-	19	3,8	5
K3/8-T40	221657	T40	50	-	19	4,3	5
K3/8-T45	221658	T45	50	-	19	5,0	5
K3/8-T47	221659	T47	50	-	19	5,0	5
K3/8-T50	221660	T50	50	-	19	5,5	5

¹⁾ Größe T20 bis T55 auch in Länge 150 mm lieferbar.



Innensechsrund Torx® TX – mit Gelenk*

Modell	Best.-Nr.	SW #	L mm	D1 mm	D2 mm	L1 mm	VE
KG3/8-T20	221710	T20	60	-	24	3,0	5
KG3/8-T25	221711	T25	60	-	24	3,0	5
KG3/8-T27	221712	T27	60	-	24	3,8	5
KG3/8-T30	221713	T30	60	-	24	3,8	5
KG3/8-T40	221714	T40	60	-	24	4,3	5
KG3/8-T45	221715	T45	60	-	24	5,0	5
KG3/8-T47	221716	T47	60	-	24	5,0	5
KG3/8-T50	221717	T50	60	-	24	5,5	5
KG3/8-T55	221718	T55	60	-	24	5,5	5



Innensechsrund Torx® TR – Tamper Resistant

Modell	Best.-Nr.	SW #	L mm	D1 mm	D2 mm	L1 mm	VE
K3/8-TR20	221750	TR20	50	-	19	3,0	5
K3/8-TR25	221751	TR25	50	-	19	3,0	5
K3/8-TR27	221752	TR27	50	-	19	3,8	5
K3/8-TR30	221753	TR30	50	-	19	3,8	5
K3/8-TR40	221754	TR40	50	-	19	4,3	5
K3/8-TR45	221755	TR45	50	-	19	5,0	5
K3/8-TR47	221756	TR47	50	-	19	5,0	5
K3/8-TR50	221757	TR50	50	-	19	5,5	5
K3/8-TR55	221758	TR55	50	-	19	5,5	5



Innenvielzahn XZN – normal

Modell	Best.-Nr.	SW #	L mm	D1 mm	D2 mm	L1 mm	VE
K3/8-XZN5	221810	M5	50	-	19	7,0	5
K3/8-XZN6	221811	M6	50	-	19	7,0	5
K3/8-XZN8	221812	M8	50	-	19	9,0	5
K3/8-XZN10	221813	M10	50	-	19	9,0	5
K3/8-XZN12	221814	M12	50	-	19	11,0	5
K3/8-XZN14	221815	M14	50	-	19	11,0	5
K3/8-XZN16	221816	M16	50	-	19	13,0	5



Innenvielzahn XZN – tief

Modell	Best.-Nr.	SW #	L mm	D1 mm	D2 mm	L1 mm	VE
K3/8-XZN5-L	221850	M5	100	-	19	7,0	5
K3/8-XZN6-L	221851	M6	100	-	19	7,0	5
K3/8-XZN8-L	221852	M8	100	-	19	9,0	5
K3/8-XZN10-L	221853	M10	100	-	19	9,0	5
K3/8-XZN12-L	221854	M12	100	-	19	11,0	5
K3/8-XZN14-L	221855	M14	100	-	19	11,0	5
K3/8-XZN16-L	221856	M16	100	-	19	13,0	5
K3/8-XZN5-120	221870	M5	120	-	19	7,0	5
K3/8-XZN6-120	221871	M6	120	-	19	7,0	5
K3/8-XZN8-120	221872	M8	120	-	19	9,0	5
K3/8-XZN10-120	221873	M10	120	-	19	9,0	5
K3/8-XZN12-120	221874	M12	120	-	19	11,0	5
K3/8-XZN14-120	221875	M14	120	-	19	11,0	5
K3/8-XZN16-120	221876	M16	120	-	19	13,0	5



Gummiring & Sicherungsstift

Modell	Best.-Nr.	Größe Zoll	-	D1 mm	D2 mm	-	VE
RS-3/8	222050	3/8	-	-	13	-	5

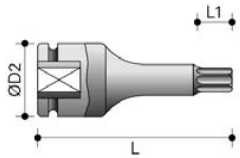

* von der Herstellergarantie ausgenommen.

Weitere Infos auf unserer Website. 

3/8 Kraftsteckschlüssel mit 3/8" Vierkantantrieb nach DIN 3121 G 10



Sechskant mit Magnet – normal

Modell	Best.-Nr.	SW mm	L mm	D1 mm	D2 mm	L2 mm	VE
KM3/8-6	220110	6	30	11,5	19	3,0	5
KM3/8-7	220111	7	30	12,5	19	3,0	5
KM3/8-8	220112	8	30	14,0	19	3,0	5
KM3/8-9	220113	9	30	15,0	19	4,0	5
KM3/8-10	220114	10	30	16,5	19	4,0	5
KM3/8-11	220115	11	30	17,5	19	5,0	5
KM3/8-12	220116	12	30	19,0	19	5,0	5
KM3/8-13	220117	13	30	20,0	22	5,0	5
KM3/8-14	220118	14	30	21,5	22	6,0	5
KM3/8-15	220119	15	30	22,0	22	6,0	5
KM3/8-16	220120	16	30	24,0	22	6,0	5
KM3/8-17	220121	17	30	25,0	22	6,0	5
KM3/8-18	220122	18	30	26,0	22	7,0	5
KM3/8-19	220123	19	30	27,5	22	7,0	5



Sechskant mit Magnet – tief

Modell	Best.-Nr.	SW mm	L mm	D1 mm	D2 mm	L2 mm	VE
KM3/8-6-L	220250	6	55	11,5	19	3,0	5
KM3/8-7-L	220251	7	55	12,5	19	3,0	5
KM3/8-8-L	220252	8	55	14,0	19	3,0	5
KM3/8-9-L	220253	9	55	15,0	19	4,0	5
KM3/8-10-L	220254	10	55	16,5	19	4,0	5
KM3/8-11-L	220255	11	55	17,5	19	5,0	5
KM3/8-12-L	220256	12	55	19,0	19	5,0	5
KM3/8-13-L	220257	13	55	20,0	22	5,0	5
KM3/8-14-L	220258	14	55	21,5	22	6,0	5
KM3/8-15-L	220259	15	55	22,0	22	6,0	5
KM3/8-16-L	220260	16	55	24,0	22	6,0	5
KM3/8-17-L	220261	17	55	25,0	22	6,0	5
KM3/8-18-L	220262	18	55	26,0	22	7,0	5
KM3/8-19-L	220263	19	55	27,5	22	7,0	5



Sechskant mit Magnet – normal – Zoll

Modell	Best.-Nr.	SW Zoll	L mm	D1 mm	D2 mm	L2 mm	VE
KM3/8-5/16	220150	5/16	34	13,8	19	3,5	5
KM3/8-3/8	220151	3/8	34	16,4	19	3,5	5
KM3/8-1/2	220152	1/2	34	20,2	22	6,0	5



Sechsrund Torx® E mit Magnet – normal

Modell	Best.-Nr.	SW #	L mm	D1 mm	D2 mm	L2 mm	VE
KM3/8-E8	220170	E8	32	11,5	19	5,0	5
KM3/8-E10	220171	E10	32	13,5	19	5,0	5
KM3/8-E11	220172	E11	32	14,0	19	5,0	5
KM3/8-E12	220173	E12	32	15,5	19	6,0	5
KM3/8-E14	220174	E14	32	17,5	19	8,0	5
KM3/8-E16	220175	E16	32	19,0	19	9,0	5
KM3/8-E18	220176	E18	32	21,0	20	9,0	5



Surface Drive mit Magnet – normal

Modell	Best.-Nr.	SW mm	L mm	D1 mm	D2 mm	L2 mm	VE
KM3/8-10-SD	220550	10	32	16,0	19	4,5	-
KM3/8-13-SD	220552	13	32	20,0	22	6,0	-
KM3/8-16-SD	220554	16	32	24,0	22	7,5	-
KM3/8-17-SD	220555	17	32	25,0	22	7,5	-

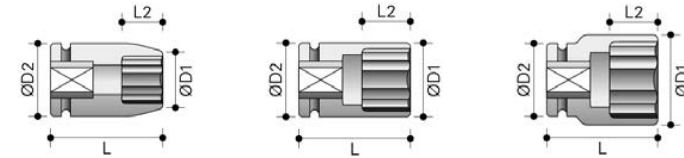

Weitere Infos auf unserer Website. 



1/2 Kraftsteckschlüssel mit 1/2" Vierkantantrieb nach DIN 3121 G 12,5



Vierkant – normal

Modell	Best.-Nr.	SW mm	L mm	D1 mm	D2 mm	L2 mm	VE
K1/2-7-VK	230487	7	40	17,5	25	8,0	5
K1/2-8-VK	230470	8	40	19,0	25	9,0	5
K1/2-10-VK	230471	10	40	21,5	25	10,0	5
K1/2-11-VK	230472	11	40	23,0	25	11,0	5
K1/2-12-VK	230473	12	40	24,0	25	12,0	5
K1/2-13-VK	230474	13	40	26,0	30	12,0	5
K1/2-14-VK	230475	14	40	27,5	30	20,0	5
K1/2-15-VK	230476	15	40	28,5	30	20,0	5
K1/2-16-VK	230477	16	40	30,0	30	20,0	5
K1/2-17-VK	230478	17	40	32,0	30	20,0	5
K1/2-18-VK	230479	18	45	34,0	30	20,0	5
K1/2-19-VK	230480	19	45	36,0	30	20,0	5
K1/2-21-VK	230481	21	45	40,0	30	20,0	5
K1/2-22-VK	230482	22	45	42,0	30	20,0	5
K1/2-24-VK	230483	24	50	44,0	30	22,0	5
K1/2-30-VK	230485	30	50	53,0	30	22,0	5
K1/2-32-VK	230486	32	50	56,0	30	22,0	5

Sechskant – normal

Modell	Best.-Nr.	SW mm	L mm	D1 mm	D2 mm	L2 mm	VE
K1/2-8	230010	8	38	14,5	25	9,0	5
K1/2-9	230011	9	38	16,0	25	12,0	5
K1/2-10	230012	10	38	17,0	25	12,0	5
K1/2-11	230013	11	38	19,0	25	12,0	5
K1/2-12	230014	12	38	20,0	24	12,0	5
K1/2-13	230015	13	38	21,0	25	12,0	5
K1/2-14	230016	14	38	22,0	25	12,0	5
K1/2-15	230017	15	38	24,0	30	12,0	5
K1/2-16	230018	16	38	25,0	30	12,0	5
K1/2-17	230019	17	38	26,0	30	13,0	5
K1/2-18	230021	18	38	27,5	30	13,0	5
K1/2-19	230022	19	38	29,0	30	13,0	5
K1/2-20	230024	20	38	30,0	30	13,0	5
K1/2-21	230025	21	38	32,0	30	13,0	5
K1/2-22	230026	22	38	32,0	30	13,0	5
K1/2-23	230027	23	38	32,5	30	13,0	5
K1/2-24	230028	24	45	35,0	30	20,0	5
K1/2-25	230029	25	45	36,0	30	20,0	5
K1/2-26	230030	26	45	37,5	30	22,0	5
K1/2-27	230031	27	50	39,0	30	22,0	5
K1/2-28	230032	28	50	40,0	30	22,0	5
K1/2-29	230033	29	50	41,0	30	22,0	5
K1/2-30	230034	30	50	42,5	30	22,0	5
K1/2-32	230035	32	50	44,0	30	28,0	5
K1/2-34	230036	34	50	45,0	30	28,0	5
K1/2-36	230037	36	50	48,0	30	28,0	5
K1/2-38	230038	38	50	53,0	38	24,0	
K1/2-41	230039	41	60	58,0	44	27,0	
K1/2-46	230040	46	70	65,0	44	30,0	
K1/2-50	230041	50	70	70,0	52	32,0	



Sechskant – normal – Zoll

Modell	Best.-Nr.	SW Zoll	L mm	D1 mm	D2 mm	L2 mm	VE
K1/2-3/8	230050	3/8	38	16,0	22	12,0	5
K1/2-7/16	230051	7/16	38	18,0	22	12,0	5
K1/2-1/2	230052	1/2	38	20,0	22	12,0	5
K1/2-9/16	230053	9/16	38	22,0	24	12,0	5
K1/2-5/8	230054	5/8	38	25,0	25	12,0	5
K1/2-11/16	230055	11/16	38	26,0	26	13,0	5
K1/2-3/4	230056	3/4	38	28,0	28	13,0	5
K1/2-13/16	230057	13/16	38	30,0	30	13,0	5
K1/2-7/8	230058	7/8	38	32,0	32	13,0	5
K1/2-15/16	230059	15/16	38	34,0	34	13,0	5
K1/2-1	230060	1	38	36,0	36	14,0	5
K1/2-1.1/16	230061	1 1/16	40	38,0	38	16,0	5
K1/2-1.1/8	230062	1 1/8	40	40,0	38	16,0	5
K1/2-1.3/16	230063	1 3/16	40	42,0	38	16,0	5
K1/2-1.1/4	230064	1 1/4	40	44,0	38	18,0	5
K1/2-1.3/8	230065	1 3/8	50	48,5	38	26,0	
K1/2-1.7/16	230066	1 7/16	50	50,5	38	26,0	
K1/2-1.1/2	230067	1 1/2	50	52,5	38	26,0	

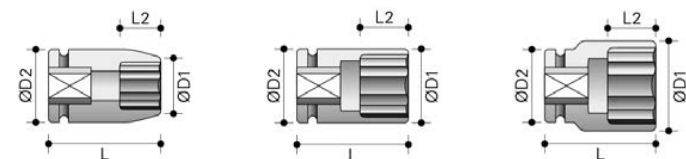

1/2 Kraftsteckschlüssel mit 1/2" Vierkantantrieb nach DIN 3121 G 12,5



Sechskant – tief

Modell	Best.-Nr.	SW mm	L mm	D1 mm	D2 mm	L2 mm	VE
K1/2-8-L	230210	8	78	14,5	25	13,0	5
K1/2-9-L	230211	9	78	16,0	25	14,0	5
K1/2-10-L	230212	10	78	17,0	25	14,0	5
K1/2-11-L	230213	11	78	18,0	25	14,0	5
K1/2-12-L	230214	12	78	19,5	25	14,0	5
K1/2-13-L	230215	13	78	21,0	25	14,0	5
K1/2-14-L	230216	14	78	22,0	25	17,0	5
K1/2-15-L	230217	15	78	23,5	30	17,0	5
K1/2-16-L	230218	16	78	23,5	30	17,0	5
K1/2-17-L	230219	17	78	26,0	30	17,0	5
K1/2-18-L	230220	18	78	26,0	30	17,0	5
K1/2-19-L	230221	19	78	28,0	30	19,0	5
K1/2-20-L	230222	20	78	30,5	30	19,0	5
K1/2-21-L	230223	21	78	31,0	30	24,0	5
K1/2-22-L	230224	22	78	32,5	30	24,0	5
K1/2-23-L	230225	23	78	32,5	30	24,0	5
K1/2-24-L	230226	24	78	35,0	30	24,0	5
K1/2-25-L	230227	25	78	36,0	30	24,0	5
K1/2-26-L	230228	26	78	37,5	30	24,0	5
K1/2-27-L	230229	27	78	38,0	30	24,0	5
K1/2-28-L	230230	28	78	40,0	30	24,0	5
K1/2-29-L	230231	29	78	40,0	30	24,0	5
K1/2-30-L	230232	30	78	42,0	30	24,0	5
K1/2-31-L	230233	31	78	43,0	30	24,0	5
K1/2-32-L	230234	32	78	45,0	30	24,0	5
K1/2-33-L	230235	33	78	45,0	30	24,0	5
K1/2-34-L	230236	34	78	45,0	30	24,0	5
K1/2-35-L	230237	35	78	47,0	30	24,0	5
K1/2-36-L	230238	36	78	49,0	30	24,0	5
K1/2-38-L	230239	38	93	53,0	38	24,0	
K1/2-41-L	230240	41	93	48,0	44	58,0	
K1/2-46-L	230241	46	93	65,0	44	58,0	

Sechskant – tief – Zoll

Modell	Best.-Nr.	SW Zoll	L mm	D1 mm	D2 mm	L2 mm	VE
K1/2-3/8-L	230258	3/8	78	16,0	22	14,0	5
K1/2-7/16-L	230250	7/16	78	18,0	22	14,0	5
K1/2-1/2-L	230251	1/2	78	20,0	22	14,0	5
K1/2-9/16-L	230252	9/16	78	22,0	24	17,0	5
K1/2-5/8-L	230253	5/8	78	26,0	26	17,0	5
K1/2-11/16-L	230254	11/16	78	26,0	26	17,0	5
K1/2-3/4-L	230255	3/4	78	28,0	28	19,0	5
K1/2-13/16-L	230256	13/16	78	30,0	30	24,0	5
K1/2-7/8-L	230257	7/8	78	32,0	32	24,0	5
K1/2-15/16-L	230259	15/16	78	34,0	34	24,0	
K1/2-1-L	230260	1"	78	36,0	36	24,0	
K1/2-1.1/16-L	230261	1 1/16	78	38,0	38	24,0	
K1/2-1.1/8-L	230262	1 1/8	78	40,0	38	24,0	
K1/2-1.3/16-L	230263	1 3/16	78	42,0	38	24,0	
K1/2-1.1/4-L	230264	1 1/4	78	44,0	38	24,0	
K1/2-1.5/16-L	230265	1 5/16	78	45,0	38	24,0	
K1/2-1.3/8-L	230266	1 3/8	78	48,5	38	24,0	
K1/2-1.7/16-L	230267	1 7/16	78	50,5	38	24,0	
K1/2-1.1/2-L	230268	1 1/2	78	52,5	38	24,0	

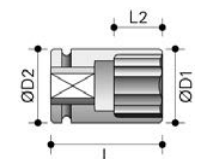

1/2 Kraftsteckschlüssel mit 1/2" Vierkantantrieb nach DIN 3121 G 12,5



Sechskant – XL & XXL

Modell	Best.-Nr.	SW mm	L mm	D1 mm	D2 mm	L2 mm	VE
K1/2-8-150	230350	8	150	15,0	25	10,0	-
K1/2-10-150	230351	10	150	17,0	25	12,0	-
K1/2-12-150	230352	12	150	19,5	25	12,0	-
K1/2-13-150	230353	13	150	20,5	25	12,0	-
K1/2-14-150	230354	14	150	22,0	25	12,0	-
K1/2-15-150	230355	15	150	23,0	25	12,0	-
K1/2-17-150	230356	17	150	25,5	25	13,0	-
K1/2-19-150	230357	19	150	28,0	25	13,0	-
K1/2-20-150	230358	20	150	30,0	25	13,0	-
K1/2-21-150	230359	21	150	30,0	25	13,0	-
K1/2-22-150	230360	22	150	32,0	30	14,0	-
K1/2-24-150	230361	24	150	34,0	30	14,0	-
K1/2-25-150	230362	25	150	36,0	30	15,0	-
K1/2-8-200	230410	8	200	15,0	25	10,0	-
K1/2-10-200	230411	10	200	17,0	25	12,0	-
K1/2-12-200	230412	12	200	19,5	25	12,0	-
K1/2-13-200	230413	13	200	20,5	25	12,0	-
K1/2-14-200	230414	14	200	22,0	25	12,0	-
K1/2-15-200	230415	15	200	23,0	25	12,0	-
K1/2-17-200	230416	17	200	25,5	25	13,0	-
K1/2-19-200	230417	19	200	28,0	25	13,0	-
K1/2-20-200	230418	20	200	30,0	25	13,0	-
K1/2-21-200	230419	21	200	30,0	25	13,0	-
K1/2-8-250	230450	8	250	15,0	25	10,0	-
K1/2-10-250	230451	10	250	17,0	25	12,0	-
K1/2-12-250	230452	12	250	19,5	25	12,0	-
K1/2-13-250	230453	13	250	20,5	25	12,0	-
K1/2-14-250	230454	14	250	22,0	25	12,0	-
K1/2-15-250	230455	15	250	23,0	25	12,0	-
K1/2-17-250	230456	17	250	25,5	25	13,0	-
K1/2-19-250	230457	19	250	28,0	25	13,0	-
K1/2-20-250	230458	20	250	30,0	25	13,0	-
K1/2-21-250	230459	21	250	30,0	25	13,0	-
K1/2-22-250	230460	22	250	32,0	30	14,0	-

Sechskant – mit Gelenk*

Modell	Best.-Nr.	SW mm	L mm	D1 mm	D2 mm	L2 mm	VE
KG1/2-10	230710	10	65	15,0	28	14,0	-
KG1/2-11	230711	11	65	17,0	28	14,0	-
KG1/2-12	230712	12	65	19,0	28	14,0	-
KG1/2-13	230713	13	65	20,0	28	14,0	-
KG1/2-14	230714	14	65	22,0	28	14,0	-
KG1/2-15	230715	15	65	23,0	28	14,0	-
KG1/2-16	230716	16	65	23,0	28	14,0	-
KG1/2-17	230717	17	65	26,0	32	14,0	-
KG1/2-18	230718	18	65	26,0	32	14,0	-
KG1/2-19	230719	19	65	28,0	32	14,0	-
KG1/2-20	230720	20	65	30,0	32	14,0	-
KG1/2-21	230721	21	65	30,0	32	14,0	-
KG1/2-22	230722	22	65	32,0	32	14,0	-
KG1/2-23	230723	23	65	32,0	32	14,0	-
KG1/2-24	230724	24	65	34,0	32	14,0	-
KG1/2-10-L	230750	10	90	15,0	28	14,0	-
KG1/2-11-L	230751	11	90	17,0	28	20,0	-
KG1/2-12-L	230752	12	90	19,0	28	20,0	-
KG1/2-13-L	230753	13	90	20,0	28	20,0	-
KG1/2-14-L	230754	14	90	22,0	28	20,0	-
KG1/2-15-L	230755	15	90	23,0	28	20,0	-
KG1/2-16-L	230756	16	90	23,0	28	20,0	-
KG1/2-17-L	230757	17	90	26,0	32	20,0	-
KG1/2-18-L	230758	18	90	26,0	32	20,0	-
KG1/2-19-L	230759	19	90	28,0	32	25,0	-
KG1/2-20-L	230760	20	90	30,0	32	25,0	-
KG1/2-21-L	230761	21	90	30,0	32	25,0	-
KG1/2-22-L	230762	22	90	32,0	32	25,0	-
KG1/2-23-L	230763	23	90	32,0	32	25,0	-
KG1/2-24-L	230764	24	90	34,0	32	25,0	-
KG1/2-15-EL	230812	15	150	22,0	25	9,0	-
KG1/2-16-EL	230813	16	150	23,0	25	9,5	-
KG1/2-17-EL	230814	17	150	25,0	25	9,5	-
KG1/2-18-EL	230815	18	150	26,0	25	11,0	-
KG1/2-19-EL	230816	19	150	28,0	25	11,5	-

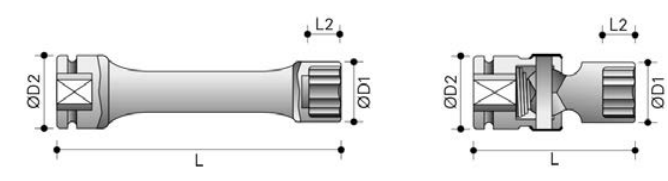

* von der Herstellergarantie ausgenommen.

Weitere Infos auf unserer Website.

24/7

1/2 Kraftsteckschlüssel mit 1/2" Vierkantantrieb nach DIN 3121 G 12,5



Sechskant – dünnwandig* – normal

Modell	Best.-Nr.	SW mm	L mm	D1 mm	D2 mm	L2 mm	VE
K1/2-8-DW	230848	8	38	13,0	25	6,0	5
K1/2-9-DW	230849	9	38	14,5	25	6,0	5
K1/2-10-DW	230850	10	38	15,5	25	7,0	5
K1/2-11-DW	230851	11	38	16,7	25	8,0	5
K1/2-12-DW	230852	12	38	18,0	25	9,0	5
K1/2-13-DW	230853	13	38	19,2	25	9,0	5
K1/2-14-DW	230854	14	38	21,0	25	11,0	5
K1/2-15-DW	230855	15	38	21,7	30	11,0	5
K1/2-16-DW	230856	16	38	23,0	30	11,0	5
K1/2-17-DW	230857	17	38	24,0	30	11,0	5
K1/2-18-DW	230858	18	38	25,0	30	13,0	5
K1/2-19-DW	230859	19	38	26,0	30	13,0	5
K1/2-20-DW	230862	20	38	27,5	30	13,0	5
K1/2-21-DW	230860	21	38	28,0	30	15,0	5
K1/2-22-DW	230861	22	38	29,5	30	15,0	5
K1/2-23-DW	230863	23	38	30,5	30	15,0	5
K1/2-24-DW	230864	24	45	32,0	30	18,0	5
K1/2-30-DW	230865	30	50	40,0	30	21,0	5

Sechskant – dünnwandig* – tief

Modell	Best.-Nr.	SW mm	L mm	D1 mm	D2 mm	L2 mm	VE
K1/2-8-DWL	230910	8	78	14,0	22	13,0	5
K1/2-9-DWL	230911	9	78	14,5	22	14,0	5
K1/2-10-DWL	230912	10	78	15,5	22	14,0	5
K1/2-11-DWL	230913	11	78	16,7	22	14,0	5
K1/2-12-DWL	230914	12	78	18,0	22	14,0	5
K1/2-13-DWL	230915	13	78	19,2	24	14,0	5
K1/2-14-DWL	230916	14	78	21,0	24	17,0	5
K1/2-15-DWL	230917	15	78	21,7	24	17,0	5
K1/2-16-DWL	230918	16	78	23,0	24	17,0	5
K1/2-17-DWL	230919	17	78	24,0	24	17,0	5
K1/2-18-DWL	230920	18	78	25,0	25	17,0	5
K1/2-19-DWL	230921	19	78	26,0	26	19,0	5
K1/2-20-DWL	230922	20	78	27,5	28	19,0	5
K1/2-21-DWL	230923	21	78	28,0	28	24,0	5
K1/2-22-DWL	230924	22	78	29,5	30	24,0	5
K1/2-23-DWL	230925	23	78	30,5	31	24,0	5
K1/2-24-DWL	230926	24	78	32,0	32	24,0	5
K1/2-25-DWL	230927	25	78	33,0	33	24,0	5
K1/2-26-DWL	230928	26	78	35,0	35	24,0	5
K1/2-27-DWL	230929	27	78	36,0	36	24,0	5
K1/2-28-DWL	230930	28	78	37,5	37,5	24,0	5
K1/2-30-DWL	230932	30	78	40,0	38	54,0	5
K1/2-31-DWL	230933	31	78	41,0	38	54,0	5
K1/2-32-DWL	230934	32	78	42,0	38	54,0	5



Sechskant Fast Lead – normal

Modell	Best.-Nr.	SW mm	L mm	D1 mm	D2 mm	L2 mm	VE
K1/2-10-FL	230610	10	38	17,0	25	8,0	5
K1/2-13-FL	230613	13	38	20,8	25	9,0	5
K1/2-15-FL	230615	15	38	23,5	30	11,0	5
K1/2-16-FL	230616	16	38	24,5	30	11,0	5
K1/2-17-FL	230617	17	38	25,7	30	12,0	5
K1/2-18-FL	230618	18	38	27,0	30	13,0	5
K1/2-19-FL	230619	19	38	28,2	30	13,0	5
K1/2-21-FL	230621	21	38	30,7	30	14,0	5
K1/2-22-FL	230622	22	38	32,0	30	15,0	5
K1/2-24-FL	230623	24	38	34,5	30	15,0	5
K1/2-27-FL	230624	27	40	38,2	30	16,0	5



Doppelvierkant – normal

Modell	Best.-Nr.	SW mm	L mm	D1 mm	D2 mm	L2 mm	VE
K1/2-10-DVK	230870	10	38	20,0	22	7,0	5
K1/2-14-DVK	230874	14	38	26,0	26	11,0	5
K1/2-17-DVK	230877	17	38	30,0	30	11,0	5
K1/2-19-DVK	230879	19	40	34,0	34	13,0	5
K1/2-22-DVK	230882	22	40	38,0	38	15,0	5
K1/2-24-DVK	230884	24	45	42,0	38	18,0	5
K1/2-27-DVK	230887	27	50	46,5	46,5	19,0	5
K1/2-28-DVK	230888	28	50	49,0	49	19,0	5

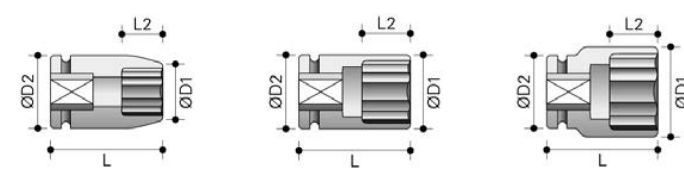

* von der Herstellergarantie ausgenommen.

Weitere Infos auf unserer Website.

24/7

1/2 Kraftsteckschlüssel mit 1/2" Vierkantantrieb nach DIN 3121 G 12,5



Surface Drive – normal

Modell	Best.-Nr.	SW mm	L mm	D1 mm	D2 mm	L2 mm	VE
K1/2-10-SD	230511	10	38	17,5	25	12,0	5
K1/2-11-SD	230512	11	38	18,7	25	12,0	5
K1/2-12-SD	230513	12	38	20,0	25	12,0	5
K1/2-13-SD	230514	13	38	21,0	25	12,0	5
K1/2-14-SD	230515	14	38	22,5	25	12,0	5
K1/2-15-SD	230516	15	38	23,7	30	12,0	5
K1/2-16-SD	230517	16	38	25,0	30	12,0	5
K1/2-17-SD	230518	17	38	26,0	30	13,0	5
K1/2-18-SD	230519	18	38	27,5	30	13,0	5
K1/2-19-SD	230520	19	38	28,7	30	13,0	5
K1/2-20-SD	230521	20	38	30,0	30	13,0	5
K1/2-21-SD	230522	21	38	30,0	30	13,0	5
K1/2-22-SD	230523	22	38	32,0	30	13,0	5
K1/2-23-SD	230524	23	38	32,0	30	13,0	5
K1/2-24-SD	230525	24	45	35,0	30	20,0	5
K1/2-26-SD	230526	26	50	38,0	30	22,0	5
K1/2-27-SD	230527	27	50	38,7	30	22,0	5
K1/2-29-SD	230528	29	50	40,0	30	22,0	5
K1/2-30-SD	230529	30	50	42,0	30	22,0	5
K1/2-32-SD	230530	32	50	44,0	30	28,0	5

Surface Drive – tief

Modell	Best.-Nr.	SW mm	L mm	D1 mm	D2 mm	L2 mm	VE
K1/2-10-SDL	230550	10	83	17,5	25	14,0	5
K1/2-11-SDL	230551	11	83	18,7	25	14,0	5
K1/2-12-SDL	230552	12	83	20,0	25	14,0	5
K1/2-13-SDL	230553	13	83	21,0	25	14,0	5
K1/2-14-SDL	230554	14	83	22,5	25	17,0	5
K1/2-15-SDL	230555	15	83	23,7	30	17,0	5
K1/2-16-SDL	230556	16	83	25,0	30	17,0	5
K1/2-17-SDL	230557	17	83	26,0	30	17,0	5
K1/2-18-SDL	230558	18	83	27,5	30	17,0	5
K1/2-19-SDL	230559	19	83	28,7	30	19,0	5
K1/2-20-SDL	230560	20	83	30,0	30	19,0	5
K1/2-21-SDL	230561	21	83	30,0	30	24,0	5
K1/2-22-SDL	230562	22	90	32,0	30	24,0	5
K1/2-23-SDL	230563	23	90	32,0	30	24,0	5
K1/2-24-SDL	230564	24	90	35,0	30	24,0	5
K1/2-26-SDL	230565	26	90	38,0	30	24,0	5
K1/2-27-SDL	230566	27	90	38,7	30	24,0	5
K1/2-29-SDL	230567	29	90	40,0	30	24,0	5
K1/2-30-SDL	230568	30	90	42,0	30	24,0	5
K1/2-32-SDL	230569	32	90	44,0	30	24,0	5



Surface Drive – dünnwandig* – normal

Modell	Best.-Nr.	SW mm	L mm	D1 mm	D2 mm	L2 mm	VE
K1/2-10-DWSD	230950	10	38	15,5	22	12,0	5
K1/2-11-DWSD	230951	11	38	16,7	22	12,0	5
K1/2-13-DWSD	230952	13	38	19,2	22	12,0	5
K1/2-14-DWSD	230960	14	38	21,0	24	12,0	5
K1/2-15-DWSD	230953	15	38	21,7	24	12,0	5
K1/2-16-DWSD	230954	16	38	23,0	24	12,0	5
K1/2-17-DWSD	230955	17	38	24,0	24	13,0	5
K1/2-18-DWSD	230956	18	38	25,0	25	13,0	5
K1/2-19-DWSD	230957	19	38	26,0	26	13,0	5
K1/2-21-DWSD	230958	21	38	29,5	28	13,0	5
K1/2-22-DWSD	230959	22	38	30,9	29,5	13,0	5

Surface Drive – dünnwandig* – tief

Modell	Best.-Nr.	SW mm	L mm	D1 mm	D2 mm	L2 mm	VE
K1/2-10-DWSDL	231010	10	83	15,5	22	14,0	5
K1/2-12-DWSDL	231012	12	83	18,0	22	14,0	5
K1/2-13-DWSDL	231013	13	83	19,2	24	14,0	5
K1/2-14-DWSDL	231014	14	83	21,0	24	17,0	5
K1/2-15-DWSDL	231015	15	83	21,7	24	17,0	5
K1/2-16-DWSDL	231016	16	83	23,0	24	17,0	5
K1/2-17-DWSDL	231017	17	83	24,0	24	17,0	5
K1/2-18-DWSDL	231018	18	83	25,0	25	17,0	5

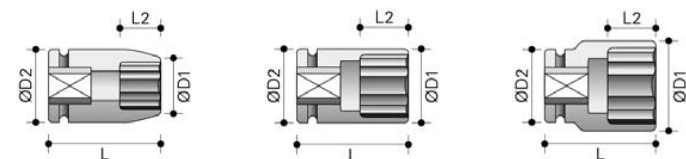

* von der Herstellergarantie ausgenommen.

Weitere Infos auf unserer Website.



1/2 Kraftsteckschlüssel mit 1/2" Vierkantantrieb nach DIN 3121 G 12,5



Doppelsechskant – normal

Modell	Best.-Nr.	SW mm	L mm	D1 mm	D2 mm	L2 mm	VE
K1/2-6-DSK	231048	6	38	13,0	25	5,0	5
K1/2-8-DSK	231050	8	38	14,0	25	6,0	5
K1/2-9-DSK	231051	9	38	16,0	25	6,0	5
K1/2-10-DSK	231052	10	38	17,5	25	7,0	5
K1/2-11-DSK	231053	11	38	19,0	25	8,0	5
K1/2-12-DSK	231054	12	38	20,0	25	9,0	5
K1/2-13-DSK	231055	13	38	21,0	25	9,0	5
K1/2-14-DSK	231056	14	38	22,5	25	11,0	5
K1/2-15-DSK	231057	15	38	23,5	30	11,0	5
K1/2-16-DSK	231058	16	38	25,0	30	11,0	5
K1/2-17-DSK	231059	17	40	26,5	30	11,0	5
K1/2-18-DSK	231060	18	40	27,5	30	13,0	5
K1/2-19-DSK	231061	19	40	29,0	30	13,0	5
K1/2-20-DSK	231062	20	40	30,0	30	13,0	5
K1/2-21-DSK	231063	21	40	31,0	30	15,0	5
K1/2-22-DSK	231064	22	40	32,5	30	15,0	5
K1/2-23-DSK	231065	23	40	34,0	30	15,0	5
K1/2-24-DSK	231066	24	45	35,0	30	18,0	5
K1/2-25-DSK	231067	25	45	36,0	30	18,0	5
K1/2-26-DSK	231068	26	50	38,0	30	18,0	5
K1/2-27-DSK	231069	27	50	39,0	30	19,0	5
K1/2-28-DSK	231070	28	50	40,0	30	19,0	5
K1/2-29-DSK	231071	29	50	41,0	30	19,0	5
K1/2-30-DSK	231072	30	50	42,5	30	21,0	5
K1/2-32-DSK	231073	32	50	44,0	30	22,0	5
K1/2-33-DSK	231074	33	50	46,5	30	22,0	5
K1/2-36-DSK	231075	36	50	50,5	30	24,0	5
K1/2-41-DSK	231077	41	60	58,5	44	27,0	
K1/2-46-DSK	231079	46	70	65,0	44	30,0	



Doppelsechskant – tief

Modell	Best.-Nr.	SW mm	L mm	D1 mm	D2 mm	L2 mm	VE
K1/2-6-DSKL	231150	6	83	13,0	25	5,0	5
K1/2-7-DSKL	231151	7	83	14,0	25	5,0	5
K1/2-8-DSKL	231152	8	83	15,0	25	6,0	5
K1/2-9-DSKL	231153	9	83	16,0	25	6,0	5
K1/2-10-DSKL	231154	10	83	17,5	25	7,0	5
K1/2-11-DSKL	231155	11	83	19,0	25	8,0	5
K1/2-12-DSKL	231156	12	83	20,0	25	9,0	5
K1/2-13-DSKL	231157	13	83	21,0	25	9,0	5

Doppelsechskant – tief

Modell	Best.-Nr.	SW mm	L mm	D1 mm	D2 mm	L2 mm	VE
K1/2-14-DSKL	231158	14	83	22,5	25	11,0	5
K1/2-15-DSKL	231159	15	83	23,5	30	11,0	5
K1/2-16-DSKL	231160	16	83	25,0	30	11,0	5
K1/2-17-DSKL	231161	17	83	26,5	30	11,0	5
K1/2-18-DSKL	231162	18	83	27,5	30	13,0	5
K1/2-19-DSKL	231163	19	83	29,0	30	13,0	5
K1/2-20-DSKL	231164	20	83	30,0	30	13,0	5
K1/2-21-DSKL	231165	21	83	31,0	30	15,0	5
K1/2-22-DSKL	231166	22	90	32,5	30	15,0	5
K1/2-23-DSKL	231167	23	90	34,0	30	15,0	5
K1/2-24-DSKL	231168	24	90	35,0	30	18,0	5
K1/2-25-DSKL	231169	25	90	36,0	30	18,0	5
K1/2-26-DSKL	231170	26	90	38,0	30	18,0	5
K1/2-27-DSKL	231171	27	90	39,0	30	19,0	5
K1/2-28-DSKL	231172	28	90	40,0	30	19,0	5
K1/2-29-DSKL	231173	29	90	41,0	30	19,0	5
K1/2-30-DSKL	231174	30	90	42,5	30	21,0	5
K1/2-31-DSKL	231175	31	90	44,0	30	21,0	5
K1/2-32-DSKL	231176	32	90	45,0	30	22,0	5
K1/2-33-DSKL	231177	33	90	46,5	30	22,0	5
K1/2-34-DSKL	231178	34	90	48,0	30	22,0	5
K1/2-35-DSKL	231179	35	90	49,5	30	22,0	5
K1/2-36-DSKL	231180	36	90	50,5	30	24,0	5
K1/2-38-DSKL	231181	38	90	53,0	38	24,0	5
K1/2-39-DSKL	231185	39	93	54,5	44	24,0	5
K1/2-40-DSKL	231186	40	93	56,0	44	58,0	5
K1/2-41-DSKL	231182	41	93	58,0	44	58,0	
K1/2-42-DSKL	231183	42	93	60,0	44	58,0	
K1/2-43-DSKL	231187	43	93	61,0	44	58,0	
K1/2-44-DSKL	231188	44	93	63,0	44	58,0	
K1/2-45-DSKL	231189	45	93	64,0	44	58,0	
K1/2-46-DSKL	231184	46	93	65,0	44	58,0	
K1/2-47-DSKL	231190	47	93	66,5	44	58,0	
K1/2-48-DSKL	231191	48	93	68,0	44	58,0	
K1/2-49-DSKL	231192	49	93	69,0	44	58,0	
K1/2-50-DSKL	231193	50	93	70,0	52	58,0	
K1/2-52-DSKL	231195	52	93	72,5	52	58,0	
K1/2-54-DSKL	231196	54	93	75,0	52	58,0	
K1/2-56-DSKL	231197	56	93	77,0	52	58,0	
K1/2-57-DSKL	231198	57	93	78,0	52	58,0	
K1/2-58-DSKL	231199	58	93	79,0	52	58,0	

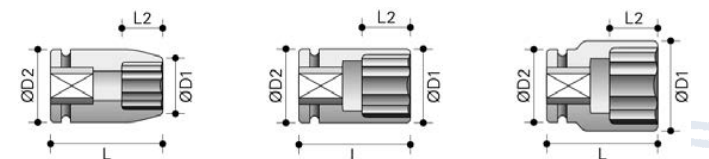

Weitere Infos auf unserer Website.

1/2 Kraftsteckschlüssel mit 1/2" Vierkantantrieb nach DIN 3121 G 12,5



Sechsrund Torx® E – normal

Modell	Best.-Nr.	SW #	L mm	D1 mm	D2 mm	L2 mm	VE
K1/2-E10	231450	E10	38	15,0	25	7,5	5
K1/2-E11	231451	E11	38	15,5	25	8,0	5
K1/2-E12	231452	E12	38	16,0	25	8,5	5
K1/2-E14	231453	E14	38	18,5	25	10,0	5
K1/2-E16	231454	E16	38	20,0	25	11,0	5
K1/2-E18	231455	E18	38	22,0	25	12,0	5
K1/2-E20	231456	E20	38	25,0	30	13,5	5
K1/2-E22	231457	E22	45	26,5	30	18,0	5
K1/2-E24	231458	E24	45	28,5	30	18,0	5



Sechsrund Torx® E – tief

Modell	Best.-Nr.	SW #	L mm	D1 mm	D2 mm	L2 mm	VE
K1/2-E10-L	231550	E10	80	14,0	25	7,0	5
K1/2-E12-L	231551	E12	80	15,0	25	8,0	5
K1/2-E14-L	231552	E14	80	18,0	25	9,0	5
K1/2-E16-L	231553	E16	80	19,0	25	10,0	5
K1/2-E18-L	231554	E18	80	22,0	30	11,0	5
K1/2-E20-L	231555	E20	80	24,0	30	13,0	5



Sechsrund Torx® E – mit Gelenk*

Modell	Best.-Nr.	SW #	L mm	D1 mm	D2 mm	T mm	VE
KG1/2-E10	231610	E10	65	13,0	28	7,5	5
KG1/2-E11	231611	E11	65	14,0	28	8,0	5
KG1/2-E12	231612	E12	65	15,0	28	8,5	5
KG1/2-E14	231613	E14	65	17,0	28	10,0	5
KG1/2-E16	231614	E16	65	18,5	28	11,0	5
KG1/2-E18	231615	E18	65	20,5	28	12,0	5
KG1/2-E20	231616	E20	70	22,5	32	13,5	5
KG1/2-E22	231617	E22	70	24,5	32	15,0	5
KG1/2-E24	231618	E24	70	26,5	32	17,0	5



Sechsrund Torx® E – dünnwandig*

Modell	Best.-Nr.	SW #	L mm	D1 mm	D2 mm	L2 mm	VE
K1/2-E10-DW	231650	E10	38	13,0	25	7,5	5
K1/2-E11-DW	231651	E11	38	14,0	25	8,0	5
K1/2-E12-DW	231652	E12	38	15,0	25	8,5	5
K1/2-E14-DW	231653	E14	38	17,0	25	10,0	5
K1/2-E16-DW	231654	E16	38	18,5	25	11,0	5
K1/2-E18-DW	231655	E18	38	20,5	25	12,0	5
K1/2-E20-DW	231656	E20	38	22,5	30	13,5	5
K1/2-E22-DW	231657	E22	45	24,5	30	18,0	5
K1/2-E24-DW	231658	E24	45	26,5	30	18,0	5

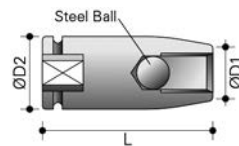

Stehbolzensetzer

Modell	Best.-Nr.	Gewinde	D1 mm	D2 mm	L mm	VE
SB1/2-M6-1.0	241210	M6 × 1.0	13	25	55	
SB1/2-M8-1.0	241217	M8 × 1.0	15	25	55	
SB1/2-M8-1.25	241218	M8 × 1.25	15	25	55	
SB1/2-M10-1.0	241220	M10 × 1.0	18	25	55	
SB1/2-M10-1.25	241221	M10 × 1.25	18	25	55	
SB1/2-M10-1.5	241222	M10 × 1.5	17	25	55	
SB1/2-M12-1.25	241225	M12 × 1.25	19	25	55	
SB1/2-M12-1.5	241226	M12 × 1.5	19	25	55	
SB1/2-M12-1.75	241227	M12 × 1.75	19	25	55	
SB1/2-M14-1.5	241230	M14 × 1.5	23	25	55	
SB1/2-M14-2.0	241231	M14 × 2.0	22	25	55	
SB1/2-M16-1.5	241234	M16 × 1.5	28	30	75	
SB1/2-M16-2.0	241235	M16 × 2.0	27	30	75	
SB1/2-M18-2.5	241236	M15 × 1.5	29.5	30	75	
SB1/2-M18-2.5	241238	M18 × 2.5	29	30	75	
SB1/2-M20-1.5	241240	M20 × 1.5	30	30	75	
SB1/2-M20-2.5	241241	M20 × 2.5	30	30	75	

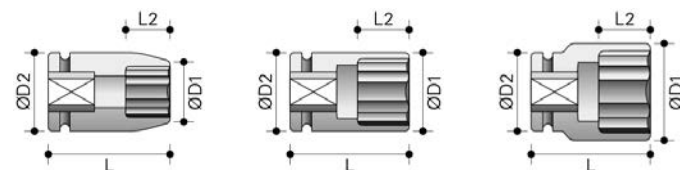

* von der Herstellergarantie ausgenommen.

Weitere Infos auf unserer Website.



24/7

1/2 Kraftsteckschlüssel mit 1/2" Vierkantantrieb nach DIN 3121 G 12,5



Halter & auswechselbare Einsätze

Modell	Best.-Nr.	SW	L mm	D1 mm	D2 mm	T mm	VE
K1/2-AWE7/16	231350	7/16	38	22,0	30	-	-
AWE7/16-A4	231417	4	56	-	-	-	5
AWE7/16-A5	231410	5	55	-	-	-	5
AWE7/16-A6	231411	6	55	-	-	-	5
AWE7/16-A7	231418	7	55	-	-	-	5
AWE7/16-A8	231412	8	55	-	-	-	5
AWE7/16-A10	231413	10	55	-	-	-	5
AWE7/16-A12	231414	12	55	-	-	-	5
AWE7/16-A14	231415	14	55	-	-	-	5
AWE7/16-A17	231416	17	55	-	-	-	5
AWE7/16-A19	231419	19	58	-	-	-	5



Innensechskant Inbus® – mit Gelenk*

Modell	Best.-Nr.	SW mm	L mm	D1 mm	D2 mm	L1 mm	VE
KG1/2-A6	231310	6	75	-	28	13,0	5
KG1/2-A7	231311	7	75	-	28	13,0	5
KG1/2-A8	231312	8	75	-	28	20,0	5
KG1/2-A9	231313	9	75	-	28	20,0	5
KG1/2-A10	231314	10	75	-	28	20,0	5
KG1/2-A11	231315	11	75	-	28	20,0	5
KG1/2-A12	231316	12	75	-	28	20,0	5
KG1/2-A13	231317	13	75	-	28	20,0	5
KG1/2-A14	231318	14	75	-	28	20,0	5
KG1/2-A15	231319	15	75	-	28	20,0	5
KG1/2-A16	231320	16	75	-	28	20,0	5
KG1/2-A17	231321	17	75	-	28	20,0	5
KG1/2-A18	231322	18	75	-	28	20,0	5
KG1/2-A19	231323	19	75	-	28	20,0	5

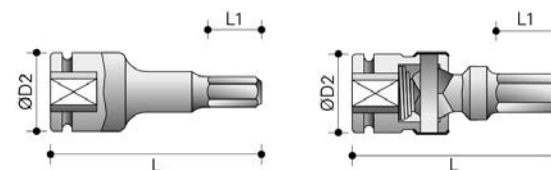

* von der Herstellergarantie ausgenommen.



Weitere Infos auf unserer Website.

24/7



Innensechskant Inbus® – normal

Modell	Best.-Nr.	SW mm	L mm	D1 mm	D2 mm	L1 mm	VE
K1/2-A4-75	231250	4	75	-	25	11,0	5
K1/2-A5-75	231251	5	75	-	25	15,0	5
K1/2-A6-75	231252	6	75	-	25	15,0	5
K1/2-A7-75	231253	7	75	-	25	15,0	5
K1/2-A8-75	231254	8	75	-	25	16,0	5
K1/2-A9-75	231255	9	75	-	25	16,0	5
K1/2-A10-75	231256	10	75	-	25	16,0	5
K1/2-A11-75	231257	11	75	-	25	16,0	5
K1/2-A12-75	231258	12	75	-	25	16,0	5
K1/2-A13-75	231259	13	75	-	25	16,0	5
K1/2-A14-75	231260	14	75	-	25	16,0	5
K1/2-A15-75	231261	15	75	-	25	16,0	5
K1/2-A16-75	231262	16	75	-	25	16,0	5
K1/2-A17-75	231263	17	75	-	25	16,0	5
K1/2-A19-75	231264	19	75	-	25	16,0	5
K1/2-A21-75	231265	21	75	-	30	16,0	5
K1/2-A22-75	231266	22	75	-	30	16,0	5
K1/2-A24-75	231267	24	75	-	30	16,0	5



Innensechskant Inbus® – tief

Modell	Best.-Nr.	SW mm	L mm	D1 mm	D2 mm	L1 mm	VE
K1/2-A6-100	231270	6	100	-	25	15,0	5
K1/2-A8-100	231272	8	100	-	25	16,0	5
K1/2-A10-100	231274	10	100	-	25	16,0	5
K1/2-A12-100	231276	12	100	-	25	16,0	5
K1/2-A14-100	231278	14	100	-	25	16,0	5
K1/2-A6-125	231286	6	125	-	25	15,0	5
K1/2-A8-125	231288	8	125	-	25	16,0	5
K1/2-A10-125	231290	10	125	-	25	16,0	5

1/2 Kraftsteckschlüssel mit 1/2" Vierkantantrieb nach DIN 3121 G 12,5



Innensechsrund Torx® TX – normal

Modell	Best.-Nr.	SW #	L mm	D1 mm	D2 mm	L1 mm	VE
K1/2-T20	240010	T20	55	-	25	2,8	5
K1/2-T25	240011	T25	55	-	25	3,0	5
K1/2-T27	240012	T27	55	-	25	3,0	5
K1/2-T30	240013	T30	55	-	25	3,8	5
K1/2-T40	240014	T40	55	-	25	3,8	5
K1/2-T45	240015	T45	55	-	25	4,3	5
K1/2-T47	240016	T47	55	-	25	5,0	5
K1/2-T50	240017	T50	55	-	25	5,0	5
K1/2-T55	240018	T55	55	-	25	5,5	5
K1/2-T60	240019	T60	55	-	25	8,0	5
K1/2-T70	240020	T70	55	-	25	9,4	5



Innensechsrund Torx® TR – normal

Modell	Best.-Nr.	SW #	L mm	D1 mm	D2 mm	L1 mm	VE
K1/2-TR20	240150	TR20	55	-	25	2,8	5
K1/2-TR25	240151	TR25	55	-	25	3,0	5
K1/2-TR27	240152	TR27	55	-	25	3,0	5
K1/2-TR30	240153	TR30	55	-	25	3,8	5
K1/2-TR40	240154	TR40	55	-	25	3,8	5
K1/2-TR45	240155	TR45	55	-	25	4,3	5
K1/2-TR47	240156	TR47	55	-	25	5,0	5
K1/2-TR50	240157	TR50	55	-	25	5,0	5
K1/2-TR55	240158	TR55	55	-	25	5,5	5
K1/2-TR60	240159	TR60	55	-	25	8,0	5
K1/2-TR70	240160	TR70	55	-	25	9,4	5



Innensechsrund Torx® TX – tief

Modell	Best.-Nr.	SW #	L mm	D1 mm	D2 mm	L1 mm	VE
K1/2-T20L	240050	T20	75	-	25	2,8	5
K1/2-T25L	240051	T25	75	-	25	3,0	5
K1/2-T27L	240052	T27	75	-	25	3,0	5
K1/2-T30L	240053	T30	75	-	25	3,8	5
K1/2-T40L	240054	T40	75	-	25	3,8	5
K1/2-T45L	240055	T45	75	-	25	4,3	5
K1/2-T47L	240056	T47	75	-	25	5,0	5
K1/2-T50L	240057	T50	75	-	25	5,0	5
K1/2-T55L	240058	T55	75	-	25	5,5	5
K1/2-T60L	240059	T60	75	-	25	8,0	5
K1/2-T70L	240060	T70	75	-	25	9,4	5
K1/2-T25-150	240075	T25	150	-	25	3,0	5
K1/2-T27-150	240076	T27	150	-	25	3,0	5
K1/2-T30-150	240077	T30	150	-	25	3,8	5
K1/2-T40-150	240078	T40	150	-	25	3,8	5
K1/2-T45-150	240079	T45	150	-	25	4,3	5



Innensechsrund Torx® TR – tief

Modell	Best.-Nr.	SW #	L mm	D1 mm	D2 mm	L1 mm	VE
K1/2-TR20L	240210	TR20	75	-	25	2,8	5
K1/2-TR25L	240211	TR25	75	-	25	3,0	5
K1/2-TR27L	240212	TR27	75	-	25	3,0	5
K1/2-TR30L	240213	TR30	75	-	25	3,8	5
K1/2-TR40L	240214	TR40	75	-	25	3,8	5
K1/2-TR45L	240215	TR45	75	-	25	4,3	5
K1/2-TR47L	240216	TR47	75	-	25	5,0	5
K1/2-TR50L	240217	TR50	75	-	25	5,0	5
K1/2-TR55L	240218	TR55	75	-	25	5,5	5
K1/2-TR60L	240219	TR60	75	-	25	8,0	5
K1/2-TR70L	240220	TR70	75	-	25	9,4	5

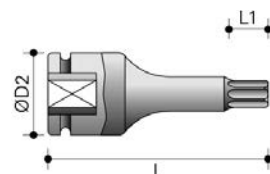

Weitere Infos auf unserer Website.



24/7

1/2 Kraftsteckschlüssel mit 1/2" Vierkantantrieb nach DIN 3121 G 12,5



Innensechsrund Torx® – mit Gelenk*

Modell	Best.-Nr.	SW #	L mm	D1 mm	D2 mm	L1 mm	VE
KG1/2-T25	240110	T25	70	-	28	3,0	5
KG1/2-T27	240111	T27	70	-	28	3,0	5
KG1/2-T30	240112	T30	70	-	28	3,8	5
KG1/2-T40	240113	T40	70	-	28	3,8	5
KG1/2-T45	240114	T45	70	-	28	4,3	5
KG1/2-T47	240115	T47	70	-	28	5,0	5
KG1/2-T50	240116	T50	70	-	28	5,0	5
KG1/2-T55	240117	T55	70	-	28	5,5	5
KG1/2-T60	240118	T60	70	-	28	8,0	5



Innensechskeil RIBE® – normal

Modell	Best.-Nr.	SW #	L mm	D1 mm	D2 mm	L1 mm	VE
K1/2-R6	240330	M6	55	-	25	5,0	5
K1/2-R7	240331	M7	55	-	25	6,5	5
K1/2-R8	240332	M8	55	-	25	7,5	5
K1/2-R10	240333	M10	55	-	25	9,0	5
K1/2-R12	240334	M12	55	-	25	10,0	5
K1/2-R14	240335	M14	55	-	25	12,0	5
K1/2-R16	240336	M16	55	-	25	14,0	5
K1/2-R18	240337	M18	55	-	25	16,0	5

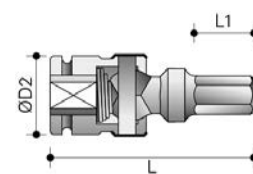

Weitere Infos auf unserer Website.

24/7



Innenvielzahn XZN – normal

Modell	Best.-Nr.	SW #	L mm	D1 mm	D2 mm	L1 mm	VE
K1/2-XZN-5	240250	M5	55	-	25	7,0	5
K1/2-XZN-6	240251	M6	55	-	25	7,0	5
K1/2-XZN-8	240252	M8	55	-	25	9,0	5
K1/2-XZN-10	240253	M10	55	-	25	9,0	5
K1/2-XZN-12	240254	M12	55	-	25	11,0	5
K1/2-XZN-14	240255	M14	55	-	25	11,0	5
K1/2-XZN-16	240256	M16	55	-	25	13,0	5



Innenvielzahn XZN – tief

Modell	Best.-Nr.	SW #	L mm	D1 mm	D2 mm	L1 mm	VE
K1/2-XZN-5L	240310	M5	100	-	25	7,0	5
K1/2-XZN-6L	240311	M6	100	-	25	7,0	5
K1/2-XZN-8L	240312	M8	100	-	25	9,0	5
K1/2-XZN-10L	240313	M10	100	-	25	9,0	5
K1/2-XZN-12L	240314	M12	100	-	25	11,0	5
K1/2-XZN-14L	240315	M14	100	-	25	11,0	5
K1/2-XZN-16L	240316	M16	100	-	25	13,0	5
K1/2-XZN-18L	240317	M18	100	-	25	13,0	5
K1/2-XZN8-120	240360	M8	120	-	25	9,0	
K1/2-XZN10-120	240361	M10	120	-	25	9,0	
K1/2-XZN12-120	240362	M12	120	-	25	11,0	
K1/2-XZN18-120	240365	M18	120	-	25	14,0	



Gumming & Sicherungsstift

Modell	Best.-Nr.	Größe Zoll	-	D1 mm	D2 mm	-	VE
RS-1/2	240510	1/2	-	-	-	-	5

1/2 Kraftsteckschlüssel mit 1/2" Vierkantantrieb nach DIN 3121 G 12,5



Sechskant mit Magnet – normal

Modell	Best.-Nr.	SW mm	L mm	D1 mm	D2 mm	L2 mm	VE
KM1/2-8	230110	8	38	15,0	25	3,0	5
KM1/2-9	230111	9	38	16,0	25	4,0	5
KM1/2-10	230112	10	38	17,5	25	4,0	5
KM1/2-11	230113	11	38	18,5	25	5,0	5
KM1/2-12	230114	12	38	20,0	25	5,0	5
KM1/2-13	230115	13	38	21,0	25	6,0	5
KM1/2-14	230116	14	38	22,5	25	6,0	5
KM1/2-15	230117	15	38	23,7	30	6,0	5
KM1/2-16	230118	16	38	25,0	30	6,0	5
KM1/2-17	230119	17	38	26,5	30	6,0	5
KM1/2-18	230120	18	38	27,5	30	7,0	5
KM1/2-19	230121	19	38	29,0	30	7,0	5
KM1/2-20	230122	20	38	30,0	30	7,0	5
KM1/2-21	230123	21	38	31,0	30	8,0	5
KM1/2-22	230124	22	38	32,5	30	8,0	5
KM1/2-24	230125	24	45	35,0	30	10,0	5

Sechsrund Torx® E mit Magnet

Modell	Best.-Nr.	SW #	L mm	D1 mm	D2 mm	L2 mm	VE
KM1/2-E10	231510	E10	38	14,5	25	5,0	5
KM1/2-E11	231515	E11	38	15,0	25	5,0	5
KM1/2-E12	231511	E12	38	16,0	25	6,0	5
KM1/2-E14	231512	E14	38	18,0	25	8,0	5
KM1/2-E16	231513	E16	38	20,0	25	9,0	5
KM1/2-E18	231514	E18	38	22,0	25	9,0	5
KM1/2-E20	231516	E20	38	25,0	30	10,0	5
KM1/2-E22	231517	E22	45	27,0	30	10,0	5
KM1/2-E24	231518	E24	45	29,0	30	11,0	5



Sechskant mit Magnet – Zoll

Modell	Best.-Nr.	SW Zoll	L mm	D1 mm	D2 mm	L2 mm	VE
KM1/2-3/8	230150	3/8	38	-	-	-	5
KM1/2-1/2	230151	1/2	38	-	-	-	5



Sechskant mit Magnet – tief

Modell	Best.-Nr.	SW mm	L mm	D1 mm	D2 mm	L2 mm	VE
KM1/2-8-L	230310	8	78	15,0	25	3,0	5
KM1/2-9-L	230311	9	78	16,0	25	4,0	5
KM1/2-10-L	230312	10	78	17,5	25	4,0	5
KM1/2-11-L	230313	11	78	18,5	25	5,0	5
KM1/2-12-L	230314	12	78	20,0	25	5,0	5
KM1/2-13-L	230315	13	78	21,0	25	5,0	5
KM1/2-14-L	230316	14	78	22,5	25	6,0	5
KM1/2-15-L	230317	15	78	23,7	30	6,0	5
KM1/2-16-L	230318	16	78	25,0	30	6,0	5
KM1/2-17-L	230319	17	78	26,5	30	6,0	5
KM1/2-18-L	230320	18	78	27,5	30	7,0	5
KM1/2-19-L	230321	19	78	29,0	30	7,0	5
KM1/2-20-L	230322	20	78	30,0	30	7,0	5
KM1/2-21-L	230323	21	78	31,0	30	8,0	5
KM1/2-22-L	230324	22	78	32,5	30	8,0	5
KM1/2-24-L	230325	24	78	35,0	30	10,0	5

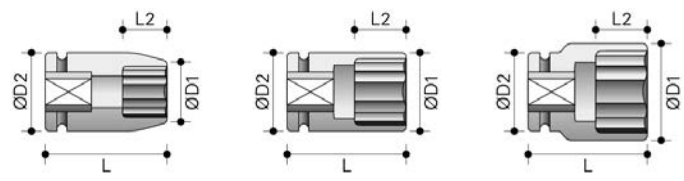

3/4 Kraftsteckschlüssel mit 3/4" Vierkantantrieb nach DIN 3121 H 20



Vierkant – normal

Modell	Best.-Nr.	SW mm	L mm	D1 mm	D2 mm	L2 mm	VE
K3/4-16-VK	250070	16	52	40,0	40	22	
K3/4-17-VK	250071	17	52	40,0	40	22	
K3/4-19-VK	250072	19	52	40,0	40	22	
K3/4-20-VK	250073	20	52	42,0	42	22	
K3/4-21-VK	250074	21	52	42,0	42	22	
K3/4-22-VK	250075	22	52	44	44	24	
K3/4-24-VK	250076	24	52	47,0	42	24	



Sechskant – normal

Modell	Best.-Nr.	SW mm	L mm	D1 mm	D2 mm	L2 mm	VE
K3/4-13	250010	13	50	25,0	44	9	-
K3/4-14	250011	14	50	25,0	44	11	-
K3/4-15	250012	15	50	26,0	44	11	-
K3/4-16	250013	16	50	27,0	44	11	-
K3/4-17	250014	17	50	31,0	44	12	-
K3/4-18	250015	18	50	32,0	44	13	-
K3/4-19	250016	19	50	33,0	44	13	-
K3/4-20	250017	20	50	34,0	44	14	-
K3/4-21	250018	21	50	35,0	44	15	-
K3/4-22	250019	22	50	37,0	44	15	-
K3/4-23	250020	23	50	38,0	44	16	-
K3/4-24	250021	24	50	40,0	44	16	-
K3/4-25	250022	25	50	40,0	44	16	-
K3/4-26	250023	26	50	41,0	44	16	-
K3/4-27	250024	27	54	43,0	44	19	-
K3/4-28	250025	28	54	44,0	44	19	-
K3/4-29	250026	29	54	45,0	44	21	-
K3/4-30	250027	30	54	47,0	44	21	-
K3/4-31	250028	31	56	48,0	44	21	-
K3/4-32	250029	32	56	49,0	44	22	-
K3/4-33	250030	33	56	51,0	44	22	-
K3/4-34	250031	34	56	52,0	44	22	-
K3/4-35	250032	35	56	53,0	44	22	-
K3/4-36	250033	36	56	54,0	44	25	-

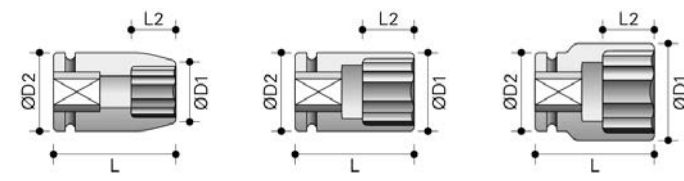

Sechskant – normal

Modell	Best.-Nr.	SW mm	L mm	D1 mm	D2 mm	L2 mm	VE
K3/4-37	250034	37	58	56,0	44	25	-
K3/4-38	250035	38	58	57,0	44	25	-
K3/4-39	250036	39	58	58,0	44	25	-
K3/4-40	250037	40	58	58,0	44	25	-
K3/4-41	250038	41	58	60,0	44	27	-
K3/4-42	250039	42	58	62,0	44	27	-
K3/4-43	250040	43	63	63,0	44	27	-
K3/4-44	250051	44	63	63,0	44	27	-
K3/4-45	250052	45	63	66,0	44	27	-
K3/4-46	250041	46	63	67,0	44	30	-
K3/4-47	250042	47	68	68,0	44	30	-
K3/4-49	250044	49	70	70,0	44	30	-
K3/4-50	250045	50	72	71,0	54	32	-
K3/4-55	250046	55	74	77,0	54	35	-
K3/4-56	250053	56	74	80,0	54	35	-
K3/4-57	250054	57	74	84,0	54	35	-
K3/4-60	250047	60	75	84,0	54	37	-
K3/4-63	250048	63	75	86,0	54	37	-
K3/4-65	250049	65	78	88,0	54	40	-
K3/4-67	250050	67	80	90,0	54	40	-
K3/4-70	250055	70	80	90,0	54	40	-
K3/4-75	250056	75	83	102	64	42	-



Sechskant – normal – Zoll

Modell	Best.-Nr.	SW Zoll	L mm	D1 mm	D2 mm	L2 mm	VE
K3/4-11/16	250110	11/16	50	29,0	38	12	-
K3/4-3/4	250111	3/4	50	30,0	38	14	-
K3/4-13/16	250112	13/16	52	32,0	38	16	-
K3/4-7/8	250113	7/8	52	34,0	38	16	-
K3/4-15/16	250114	15/16	52	36,0	38	16	-
K3/4-1	250115	1"	52	40,0	38	16	-
K3/4-1.1/16	250116	1 1/16	52	40,0	38	16	-
K3/4-1.1/8	250117	1 1/8	52	42,0	42	20	-
K3/4-1.3/16	250118	1 3/16	52	44,0	44	20	-
K3/4-1.1/4	250119	1 1/4	52	44,0	44	20	-
K3/4-1.5/16	250120	1 5/16	56	47,0	44	23	-
K3/4-1.3/8	250121	1 3/8	56	50,0	44	23	-
K3/4-1.7/16	250122	1 7/16	56	51,0	44	23	-
K3/4-1.1/2	250123	1 1/2	56	53,0	44	23	-
K3/4-1.3/4	250125	1 3/4	56	65,0	44	27	-
K3/4-1.13/16	250124	1 13/16	56	67,0	44	32	-



Sechskant – tief

Modell	Best.-Nr.	SW mm	L mm	D1 mm	D2 mm	L2 mm	VE
K3/4-13L	250150	13	95	25,0	44	13	-
K3/4-14L	250151	14	95	25,0	44	14	-
K3/4-15L	250152	15	95	26,0	44	15	-
K3/4-17L	250154	17	95	31,0	44	17	-
K3/4-18L	250155	18	95	32,0	44	18	-
K3/4-19L	250156	19	95	33,0	44	19	-
K3/4-20L	250157	20	95	34,0	44	20	-
K3/4-21L	250158	21	95	36,0	44	21	-
K3/4-22L	250159	22	95	37,0	44	22	-
K3/4-23L	250160	23	95	38,0	44	23	-
K3/4-24L	250161	24	95	39,5	44	24	-
K3/4-25L	250162	25	95	40,0	44	25	-
K3/4-26L	250163	26	95	41,0	44	26	-
K3/4-27L	250164	27	95	43,0	44	27	-
K3/4-28L	250165	28	95	44,0	44	28	-
K3/4-29L	250166	29	95	45,0	44	29	-
K3/4-30L	250167	30	95	47,0	44	31	-
K3/4-31L	250168	31	95	48,0	44	31	-
K3/4-32L	250169	32	95	49,0	44	32	-
K3/4-33L	250170	33	95	51,0	44	33	-
K3/4-34L	250171	34	95	52,0	44	34	-
K3/4-35L	250172	35	95	54,0	44	35	-
K3/4-36L	250173	36	95	55,0	44	36	-
K3/4-37L	250174	37	95	55,0	44	37	-
K3/4-38L	250175	38	95	57,0	44	38	-
K3/4-39L	250176	39	95	58,0	44	38	-
K3/4-40L	250177	40	95	58,0	44	38	-
K3/4-41L	250178	41	95	60,0	44	38	-
K3/4-42L	250179	42	95	62,0	44	38	-
K3/4-43L	250180	43	95	63,0	44	38	-
K3/4-44L	250181	44	95	65,0	44	38	-
K3/4-46L	250183	46	95	67,0	44	38	-
K3/4-47L	250184	47	95	68,0	44	38	-
K3/4-48L	250185	48	95	69,0	44	38	-
K3/4-49L	250186	49	95	70,0	44	38	-
K3/4-50L	250187	50	95	71,0	54	38	-
K3/4-52L	250188	52	95	74,0	54	40	-
K3/4-55L	250189	55	100	77,0	54	40	-
K3/4-60L	250190	60	105	84,0	54	42	-
K3/4-65L	250191	65	105	88,0	54	66	-

Sechskant – tief – Zoll

Modell	Best.-Nr.	SW Zoll	L mm	D1 mm	D2 mm	L2 mm	VE
K3/4-13/16-L	250210	13/16	85	32,0	38	23	-
K3/4-7/8-L	250211	7/8	85	34,0	38	23	-
K3/4-15/16-L	250212	15/16	85	36,0	38	41	-
K3/4-1-L	250213	1"	85	40,0	38	41	-
K3/4-1 1/8-L	250214	1 1/8	85	42,0	42	52	-
K3/4-1.3/16-L	250215	1 3/16	85	44,0	44	52	-
K3/4-1.1/4-L	250216	1 1/4	85	44,0	44	52	-
K3/4-1.5/16-L	250217	1 5/16	85	47,0	44	52	-
K3/4-1.7/16-L	250218	1 7/16	85	51,0	44	52	-
K3/4-1.1/2-L	250219	1 1/2	85	53,0	44	60	-



Sechskant – XL & XXL

Modell	Best.-Nr.	SW mm	L mm	D1 mm	D2 mm	L2 mm	VE
K3/4-24-270	250250	24	270	38,9	44	24	-
K3/4-27-270	250251	27	270	42,5	44	27	-
K3/4-30-270	250252	30	270	46,5	44	30	-
K3/4-32-270	250253	32	270	48,8	44	32	-
K3/4-33-270	250254	33	270	50,0	44	32	-
K3/4-36-270	250255	36	270	53,8	44	32	-
K3/4-46-270	250259	46	270	63,0	44	38	-
K3/4-24-400	250270	24	400	38,5	44	24	-
K3/4-27-400	250271	27	400	42,0	44	27	-
K3/4-30-400	250272	30	400	45,0	44	30	-
K3/4-32-400	250273	32	400	47,0	44	32	-
K3/4-33-400	250274	33	400	48,0	44	32	-
K3/4-36-400	250275	36	400	53,5	44	32	-



Sechskant – mit Gelenk* – XL

Modell	Best.-Nr.	SW mm	L mm	D1 mm	D2 mm	L2 mm	VE
KG3/4-19	250351	19	150	38,0	44	13	-
KG3/4-24	250353	24	150	43,0	44	15	-

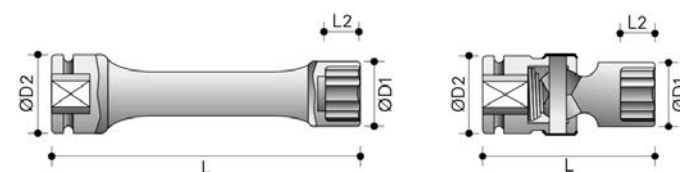

* von der Herstellergarantie ausgenommen.

Weitere Infos auf unserer Website.



Sechskant – dünnwandig* – tief

Modell	Best.-Nr.	SW mm	L mm	D1 mm	D2 mm	L2 mm	VE
K3/4-17-DWL	250311	17	95	25,5	44	17	-
K3/4-19-DWL	250313	19	95	28,5	44	19	-
K3/4-22-DWL	250315	22	95	33,5	44	22	-
K3/4-24-DWL	250316	24	95	36,5	44	24	-
K3/4-27-DWL	250317	27	95	40,5	44	27	-
K3/4-30-DWL	250318	30	95	43,5	44	30	-
K3/4-32-DWL	250319	32	95	46,5	44	32	-
K3/4-33-DWL	250320	33	95	47,5	44	33	-
K3/4-36-DWL	250322	36	95	52,0	44	36	-
K3/4-38-DWL	250323	38	95	54,0	44	38	-
K3/4-41-DWL	250324	41	95	57,0	44	38	-



Sechskant – extra dünnwandig* – tief

Modell	Best.-Nr.	SW mm	L mm	D1 mm	D2 mm	L2 mm	VE
K3/4-27-DW-108	250330	27	108	40,0	43	43	-
K3/4-32-DW-108	250332	32	108	45,0	45	43	-
K3/4-41-DW-108	250337	41	108	54,5	45	43	-



Doppelvierkant – normal

Modell	Best.-Nr.	SW mm	L mm	D1 mm	D2 mm	L2 mm	VE
K3/4-19-DVK	250080	19	52	41	41,0	15	-
K3/4-24-DVK	250081	24	52	46	44,5	20	-
K3/4-27-DVK	250082	27	56	53	44,5	24	-
K3/4-30-DVK	250083	30	60	60	44,5	28	-
K3/4-32-DVK	250084	32	60	60	44,5	28	-
K3/4-38-DVK	250085	38	64	70	44,5	32	-

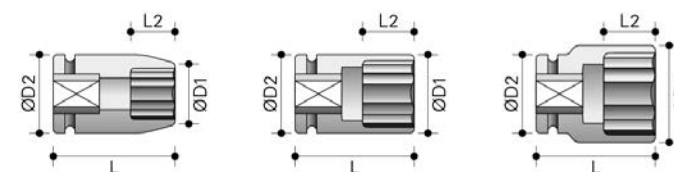

* von der Herstellergarantie ausgenommen.

Weitere Infos auf unserer Website.



3/4 Kraftsteckschlüssel mit 3/4" Vierkantantrieb nach DIN 3121 H 20



Doppelsechskant – tief

Modell	Best.-Nr.	SW mm	L mm	D1 mm	D2 mm	L2 mm	VE
K3/4-13DSKL	250450	13	95	24,5	44	13	-
K3/4-14DSKL	250451	14	95	25,5	44	14	-
K3/4-15DSKL	250452	15	95	27,0	44	15	-
K3/4-16DSKL	250453	16	95	28,0	44	16	-
K3/4-17DSKL	250454	17	95	29,5	44	17	-
K3/4-18DSKL	250455	18	95	31,0	44	18	-
K3/4-19DSKL	250456	19	95	32,0	44	19	-
K3/4-20DSKL	250457	20	95	34,0	44	20	-
K3/4-21DSKL	250458	21	95	35,0	44	21	-
K3/4-22DSKL	250459	22	95	37,0	44	22	-
K3/4-23DSKL	250460	23	95	38,0	44	23	-
K3/4-24DSKL	250461	24	95	39,0	44	24	-
K3/4-25DSKL	250462	25	95	41,0	44	25	-
K3/4-26DSKL	250463	26	95	42,0	44	26	-
K3/4-27DSKL	250464	27	95	43,0	44	27	-
K3/4-28DSKL	250465	28	95	44,0	44	28	-
K3/4-29DSKL	250466	29	95	46,0	44	29	-
K3/4-30DSKL	250467	30	95	47,0	44	30	-
K3/4-31DSKL	250468	31	95	48,0	44	31	-
K3/4-32DSKL	250469	32	95	49,0	44	32	-
K3/4-33DSKL	250470	33	95	51,0	44	33	-
K3/4-34DSKL	250471	34	95	52,0	44	34	-
K3/4-35DSKL	250472	35	95	53,0	44	35	-
K3/4-36DSKL	250473	36	95	54,0	44	36	-
K3/4-37DSKL	250474	37	95	56,0	44	37	-
K3/4-38DSKL	250475	38	95	57,0	44	38	-
K3/4-39DSKL	250476	39	95	58,0	44	38	-
K3/4-40DSKL	250477	40	95	59,5	44	38	-
K3/4-41DSKL	250478	41	95	61,0	44	38	-
K3/4-42DSKL	250479	42	95	62,0	44	38	-
K3/4-43DSKL	250480	43	95	63,5	44	38	-
K3/4-44DSKL	250481	44	95	64,5	44	38	-
K3/4-45DSKL	250482	45	95	65,5	44	38	-
K3/4-46DSKL	250483	46	100	66,5	44	38	-
K3/4-47DSKL	250484	47	100	68,0	44	38	-
K3/4-48DSKL	250485	48	100	69,0	44	38	-
K3/4-49DSKL	250486	49	100	70,0	44	38	-
K3/4-50DSKL	250487	50	100	71,0	54	38	-
K3/4-51DSKL	250488	51	100	72,0	54	40	-
K3/4-52DSKL	250489	52	100	74,0	54	40	-
K3/4-53DSKL	250490	53	100	75,0	54	40	-
K3/4-55DSKL	250492	55	105	78,0	54	40	-
K3/4-56DSKL	250493	56	105	79,0	54	40	-
K3/4-57DSKL	250494	57	105	80,0	54	40	-

Doppelsechskant – tief

Modell	Best.-Nr.	SW mm	L mm	D1 mm	D2 mm	L2 mm	VE
K3/4-58DSKL	250495	58	105	81,0	54	40	-
K3/4-60DSKL	250496	60	105	84,0	54	42	-
K3/4-63DSKL	250497	63	105	87,0	54	42	-
K3/4-65DSKL	250498	65	105	90,0	54	66	-
K3/4-67DSKL	250499	67	105	92,0	54	66	-
K3/4-68DSKL	250500	68	105	94,0	54	66	-
K3/4-70DSKL	250501	70	105	96,0	54	66	-
K3/4-73DSKL	250502	73	108	100	54	66	-
K3/4-75DSKL	250503	75	108	102	64	68	-



Sechsrund Torx® E – normal

Modell	Best.-Nr.	SW #	L mm	D1 mm	D2 mm	L2 mm	VE
K3/4-E18	250570	E18	56	25	44	12,5	-
K3/4-E20	250571	E20	56	27	44	14,0	-
K3/4-E24	250573	E24	56	33	44	16,5	-
K3/4-E32	250577	E32	56	44	44	24,5	-

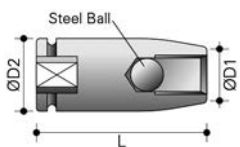

Stehbolzensetzer

Modell	Best.-Nr.	Gewinde	D1 mm	D2 mm	L mm	VE
SB3/4-M16-2.0	251162	M16 x 2.0	29	44	100	-
SB3/4-M20-2.5	251203	M20 x 2.5	35	44	100	-
SB3/4-M24-1.5	251241	M24 x 1.5	37	44	100	-
SB3/4-M24-3.0	251244	M24 x 3.0	37	44	100	-
SB3/4-M27-3.0	251274	M27 x 3.0	42	44	100	-
SB3/4-M28-3.5	251285	M28 x 3.5	42	44	100	-
SB3/4-M30-3.5	251305	M30 x 3.5	43	44	100	-

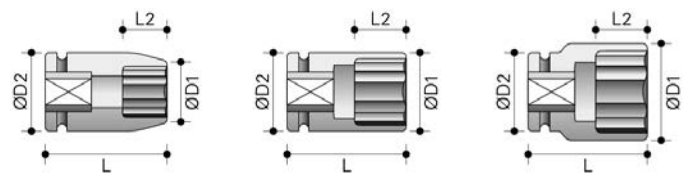

3/4 Kraftsteckschlüssel mit 3/4" Vierkantantrieb nach DIN 3121 H 20



Halter & auswechselbare Einsätze

Modell	Best.-Nr.	SW mm	L mm	D1 mm	D2 mm	T mm	VE
K3/4-AWE16	250650	16	52	32,0	44	16,0	-
AWE16-A10	250710	10	40	-	-	-	-
AWE16-A12	250711	12	40	-	-	-	-
AWE16-A14	250712	14	40	-	-	-	-
AWE16-A17	250713	17	40	-	-	-	-
AWE16-A19	250714	19	40	-	-	-	-
AWE16-A22	250715	22	40	-	-	-	-
AWE16-A24	250716	24	40	-	-	-	-



Innensechskant Inbus® – normal

Modell	Best.-Nr.	SW mm	L mm	D1 mm	D2 mm	L1 mm	VE
K3/4-A12	250549	12	62	-	44	11,0	-
K3/4-A14	250550	14	62	-	44	11,0	-
K3/4-A17	250551	17	62	-	44	13,0	-
K3/4-A19	250552	19	62	-	44	18,0	-
K3/4-A22	250553	22	62	-	44	18,0	-
K3/4-A24	250554	24	62	-	44	20,0	-
K3/4-A27	250555	27	62	-	44	20,0	-
K3/4-A30	250556	30	62	-	44	20,0	-
K3/4-A32	250557	32	62	-	44	20,0	-

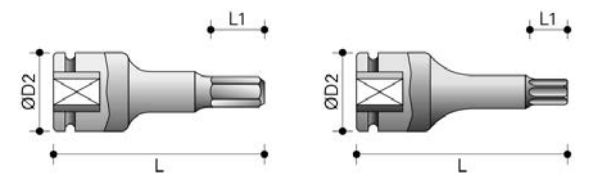

Innensechskant Inbus® – tief

Modell	Best.-Nr.	SW mm	L mm	D1 mm	D2 mm	L1 mm	VE
K3/4-A10-L	250610	10	100	-	44	20,0	-
K3/4-A12-L	250611	12	100	-	44	20,0	-
K3/4-A14-L	250612	14	100	-	44	20,0	-
K3/4-A17-L	250613	17	100	-	44	20,0	-
K3/4-A19-L	250614	19	100	-	44	20,0	-
K3/4-A22-L	250615	22	100	-	44	20,0	-
K3/4-A24-L	250616	24	100	-	44	20,0	-
K3/4-A27-L	250617	27	100	-	44	20,0	-
K3/4-A30-L	250618	30	100	-	44	20,0	-
K3/4-A32-L	250619	32	100	-	44	20,0	-
K3/4-A36-L	250620	36	100	-	44	20,0	-



Innensechsrund Torx® TX – tief

Modell	Best.-Nr.	SW #	L mm	D1 mm	D2 mm	L1 mm	VE
K3/4-T50L	250750	T50	100	-	44	5,0	-
K3/4-T55L	250751	T55	100	-	44	5,5	-
K3/4-T60L	250752	T60	100	-	44	8,0	-
K3/4-T70L	250753	T70	100	-	44	9,4	-
K3/4-T80L	250754	T80	100	-	44	10,5	-
K3/4-T90L	250755	T90	100	-	44	11,8	-
K3/4-T100L	250756	T100	100	-	44	13,1	-



Gummiring und Sicherungsstift

Modell	Best.-Nr.	Größe Zoll	-	D1 mm	D2 mm	-	VE
RS-3/4	250810	3/4	-	-	-	-	5

1 Kraftsteckschlüssel mit 1" Vierkantantrieb nach DIN 3121 H 25



Vierkant – normal

Modell	Best.-Nr.	SW #	L mm	D1 mm	D2 mm	L2 mm	VE
K1-17-VK	260001	17	57	52,0	52	24	
K1-19-VK	260002	19	57	52,0	52	24	
K1-20-VK	260003	20	57	52,0	52	24	
K1-21-VK	260004	21	57	52,0	52	24	
K1-1-VK	260201	1"	60	52,0	54	30	



Sechskant – normal

Modell	Best.-Nr.	SW mm	L mm	D1 mm	D2 mm	L2 mm	VE
K1-17	260010	17	60	34,0	54	12	-
K1-18	260011	18	60	35,0	54	13	-
K1-19	260012	19	60	35,5	54	13	-
K1-20	260013	20	60	37,0	54	14	-
K1-21	260014	21	60	37,5	54	15	-
K1-22	260015	22	60	40,0	54	15	-
K1-23	260016	23	60	41,0	54	16	-
K1-24	260017	24	60	42,0	54	18	-
K1-25	260018	25	60	43,0	54	18	-
K1-26	260019	26	60	44,5	54	18	-
K1-27	260020	27	60	46,0	54	19	-
K1-28	260021	28	62	47,0	54	19	-
K1-29	260022	29	62	48,0	54	19	-
K1-30	260023	30	62	50,0	54	21	-
K1-31	260024	31	62	51,0	54	21	-
K1-32	260025	32	62	52,0	54	22	-
K1-33	260026	33	62	53,0	54	22	-
K1-34	260027	34	62	55,0	54	22	-
K1-35	260028	35	65	56,0	54	22	-
K1-36	260029	36	67	57,0	54	25	-
K1-37	260030	37	67	59,0	54	25	-
K1-38	260031	38	67	59,5	54	25	-
K1-39	260032	39	70	60,0	54	25	-
K1-40	260033	40	70	62,0	54	25	-
K1-41	260034	41	70	64,0	54	27	-
K1-42	260035	42	74	65,0	54	27	-
K1-43	260036	43	74	66,0	54	27	-
K1-45	260037	45	74	68,0	54	27	-
K1-46	260038	46	76	69,5	54	30	-
K1-47	260039	47	76	72,0	54	32	-
K1-48	260040	48	76	73,0	54	32	-
K1-50	260041	50	80	74,0	54	35	-

Sechskant – normal

Modell	Best.-Nr.	SW mm	L mm	D1 mm	D2 mm	L2 mm	VE
K1-52	260042	52	84	77,0	54	35	-
K1-53	260043	53	84	78,0	54	35	-
K1-54	260044	54	84	79,0	54	35	-
K1-55	260045	55	84	81,0	54	35	-
K1-56	260046	56	84	83,0	54	40	-
K1-57	260047	57	84	84,0	54	40	-
K1-58	260048	58	87	85,0	54	40	-
K1-60	260049	60	87	87,0	54	42	-
K1-62	260050	62	87	89,0	54	42	-
K1-63	260051	63	87	90,0	54	42	-
K1-65	260052	65	90	93,0	54	42	-
K1-70	260053	70	96	100,0	54	42	-
K1-75	260054	75	98	106,0	86	45	-
K1-80	260055	80	100	112,0	86	48	-
K1-85	260056	85	105	118,0	86	52	-
K1-90	260057	90	105	125,0	86	52	-
K1-95	260058	95	115	131,0	86	52	-
K1-100	260059	100	115	137,0	95	58	-
K1-105	260060	105	115	143,0	95	58	-



Sechskant – normal – Zoll

Modell	Best.-Nr.	SW Zoll	L mm	D1 mm	D2 mm	L2 mm	VE
K1-1/1	260109	1"	58	42,0	51	18	-
K1-1.1/8	260110	1 1/8	58	46,0	51	19	-
K1-1.5/16	260111	1 5/16	62	53,0	52	21	-
K1-1.7/16	260112	1 7/16	62	56,0	52	26	-
K1-1.1/2	260113	1 1/2	62	58,0	52	26	-
K1-1.11/16	260114	1 11/16	64	65,0	52	27	-
K1-1.7/8	260115	1 7/8	66	70,0	58	28	-
K1-2.1/16	260116	2 1/16	70	75,0	58	31	-
K1-2.1/4	260117	2 1/4	75	84,0	62	34	-
K1-2.7/16	260118	2 7/16	78	89,0	62	35	-
K1-2.1/2	260119	2 1/2	80	91,0	62	36	-
K1-2.7/8	260120	2 7/8	87	102,0	62	41	-

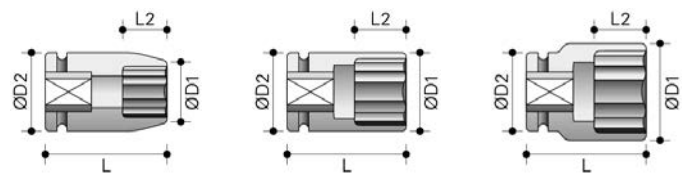

1 Kraftsteckschlüssel mit 1" Vierkantantrieb nach DIN 3121 H 25



Sechskant – tief

Modell	Best.-Nr.	SW mm	L mm	D1 mm	D2 mm	L2 mm	VE
K1-17-L	260150	17	100	34,0	54	17	-
K1-18-L	260151	18	100	34,0	54	18	-
K1-19-L	260152	19	100	35,5	54	19	-
K1-20-L	260153	20	100	36,5	54	20	-
K1-21-L	260154	21	100	37,5	54	21	-
K1-22-L	260155	22	100	40,0	54	22	-
K1-23-L	260156	23	100	41,0	54	23	-
K1-24-L	260157	24	100	42,0	54	24	-
K1-25-L	260158	25	100	43,0	54	25	-
K1-26-L	260159	26	100	44,5	54	26	-
K1-27-L	260160	27	100	46,0	54	27	-
K1-28-L	260161	28	100	47,0	54	28	-
K1-29-L	260162	29	100	48,0	54	29	-
K1-30-L	260163	30	100	50,0	54	30	-
K1-31-L	260164	31	100	51,0	54	31	-
K1-32-L	260165	32	100	52,0	54	32	-
K1-33-L	260166	33	100	53,0	54	33	-
K1-34-L	260167	34	100	55,0	54	34	-
K1-35-L	260168	35	100	56,0	54	35	-
K1-36-L	260169	36	100	57,0	54	36	-
K1-37-L	260170	37	100	57,0	54	37	-
K1-38-L	260171	38	100	59,5	54	38	-
K1-39-L	260172	39	100	61,0	54	38	-
K1-40-L	260173	40	100	62,0	54	38	-
K1-41-L	260174	41	100	64,0	54	38	-
K1-42-L	260175	42	100	65,0	54	38	-
K1-46-L	260176	46	100	69,5	54	38	-
K1-47-L	260177	47	100	71,5	54	38	-
K1-48-L	260178	48	100	72,5	54	38	-
K1-50-L	260179	50	100	75,0	54	38	-
K1-54-L	260180	54	100	80,0	54	40	-
K1-55-L	260181	55	100	81,0	54	40	-
K1-56-L	260182	56	100	82,0	54	40	-
K1-58-L	260183	58	105	85,0	54	40	-
K1-60-L	260184	60	105	87,0	54	42	-
K1-65-L	260185	65	120	93,0	54	42	-
K1-70-L	260186	70	125	100,0	54	42	-
K1-75-L	260187	75	135	106,0	86	45	-

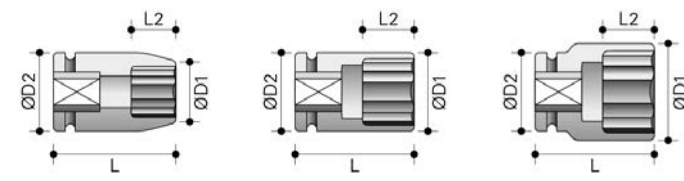

Sechskant – tief

Modell	Best.-Nr.	SW mm	L mm	D1 mm	D2 mm	L2 mm	VE
K1-80-L	260188	80	135	112,0	86	48	-
K1-85-L	260189	85	140	118,0	86	52	-
K1-90-L	260190	90	140	125,0	86	52	-
K1-95-L	260191	95	140	131,0	86	52	-
K1-100-L	260192	100	140	137,0	95	58	-
K1-105-L	260193	105	155	143,0	95	58	-
K1-110-L	260194	110	155	149,0	95	60	-
K1-115-L	260195	115	155	155,0	95	62	-



Sechskant – tief – Zoll

Modell	Best.-Nr.	SW Zoll	L mm	D1 mm	D2 mm	L2 mm	VE
K1-15/16-L	260250	15/16	90	40,0	51	21	-
K1-1-L	260255	1"	90	42,0	51	25	-
K1-1.1/16-L	250251	1 1/16	90	44,0	51	23	-
K1-1.3/16-L	250252	1 3/16	90	48,0	51	40	-
K1-1.5/16-L	260253	1 5/16	90	53,0	52	40	-
K1-1.1/2-L	260254	1 1/2	92	58,0	52	54	-



Sechskant – XL & XXL

Modell	Best.-Nr.	SW mm	L mm	D1 mm	D2 mm	L2 mm	VE
K1-24-270	260310	24	270	42,0	54	24	-
K1-27-270	260312	27	270	45,0	54	27	-
K1-30-270	260313	30	270	50,0	54	30	-
K1-32-270	260314	32	270	52,0	54	32	-
K1-33-270	260315	33	270	52,0	54	32	-
K1-36-270	260316	36	270	57,0	54	36	-
K1-32-400	260320	32	400	48,5	54	32	-
K1-33-400	260321	33	400	50,0	54	32	-

1 Kraftsteckschlüssel mit 1" Vierkantantrieb nach DIN 3121 H 25



Sechskant – dünnwandig – tief

Modell	Best.-Nr.	SW mm	L mm	D1 mm	D2 mm	L2 mm	VE
K1-19-DWL	260410	19	100	33,0	54	19	-
K1-24-DWL	260412	24	100	38,0	54	24	-
K1-27-DWL	260413	27	100	42,5	54	27	-
K1-28-DWL	260414	28	100	43,0	54	28	-
K1-30-DWL	260415	30	100	45,0	54	30	-
K1-32-DWL	260416	32	100	47,0	54	32	-
K1-33-DWL	260417	33	100	49,0	54	33	-
K1-36-DWL	260418	36	100	52,0	54	36	-
K1-41-DWL	260419	41	100	57,0	54	38	-



Doppelvierkant – normal

Modell	Best.-Nr.	SW mm	L mm	D1 mm	D2 mm	L2 mm	VE
K1-19-DVK	260080	19	60	45,0	54	13	-
K1-24-DVK	260081	24	60	52,0	54	18	-
K1-27-DVK	260082	27	60	56,5	54	19	-
K1-30-DVK	260083	30	62	61,0	54	21	-
K1-32-DVK	260084	32	62	64,0	54	22	-
K1-35-DVK	260085	35	65	68,5	58	22	-
K1-38-DVK	260086	38	67	73,0	58	24	-
K1-46-DVK	260087	46	76	86,0	62	30	-



Doppelsechskant – normal

Modell	Best.-Nr.	SW mm	L mm	D1 mm	D2 mm	L2 mm	VE
K1-16-DSK	260450	16	60	32,0	54	11	-
K1-17-DSK	260451	17	60	34,0	54	11	-
K1-18-DSK	260452	18	60	35,0	54	13	-
K1-19-DSK	260453	19	60	36,0	54	13	-
K1-20-DSK	260454	20	60	37,0	54	13	-
K1-21-DSK	260455	21	60	38,0	54	15	-
K1-22-DSK	260456	22	60	39,0	54	15	-
K1-23-DSK	260457	23	60	40,0	54	15	-
K1-24-DSK	260458	24	60	41,0	54	18	-
K1-25-DSK	260459	25	60	43,0	54	18	-
K1-26-DSK	260460	26	60	44,5	54	18	-
K1-27-DSK	260461	27	60	45,0	54	19	-
K1-28-DSK	260462	28	62	46,5	54	19	-
K1-29-DSK	260463	29	62	48,0	54	19	-
K1-30-DSK	260464	30	62	50,0	54	21	-
K1-31-DSK	260465	31	62	51,0	54	21	-
K1-32-DSK	260466	32	62	52,0	54	22	-
K1-33-DSK	260467	33	62	53,0	54	22	-
K1-34-DSK	260468	34	62	55,0	54	22	-
K1-35-DSK	240469	35	65	56,0	54	22	-
K1-36-DSK	260470	36	67	57,0	54	24	-
K1-37-DSK	260471	37	67	59,0	54	24	-
K1-38-DSK	260472	38	67	60,0	54	24	-
K1-39-DSK	260473	39	70	61,0	54	24	-
K1-40-DSK	260474	40	70	62,0	54	24	-
K1-41-DSK	260475	41	70	63,5	54	27	-
K1-42-DSK	260476	42	74	65,0	54	27	-
K1-43-DSK	260477	43	74	66,0	54	27	-
K1-44-DSK	260478	44	74	67,0	54	27	-
K1-45-DSK	260479	45	74	68,0	54	27	-
K1-46-DSK	260480	46	76	70,0	58	30	-
K1-47-DSK	260481	47	76	71,5	58	30	-
K1-48-DSK	260482	48	76	72,5	58	30	-
K1-50-DSK	260483	50	80	75,0	62	32	-
K1-51-DSK	260484	51	80	76,0	62	32	-
K1-52-DSK	260485	52	84	77,0	62	32	-
K1-53-DSK	260486	53	84	78,0	62	32	-
K1-54-DSK	260487	54	84	80,0	62	32	-

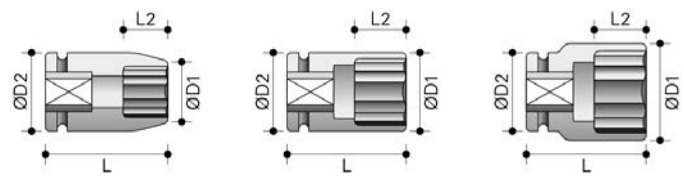

1 Kraftsteckschlüssel mit 1" Vierkantantrieb nach DIN 3121 H 25

Doppelsechskant – normal

Modell	Best.-Nr.	SW mm	L mm	D1 mm	D2 mm	L2 mm	VE
K1-55-DSK	260488	55	84	81,0	62	35	-
K1-56-DSK	260489	56	84	82,0	62	35	-
K1-57-DSK	260490	57	84	84,0	62	35	-
K1-58-DSK	260491	58	87	85,0	62	37	-
K1-60-DSK	260492	60	87	87,0	62	37	-
K1-62-DSK	260493	62	87	89,0	62	37	-
K1-63-DSK	260494	63	87	90,0	62	37	-
K1-65-DSK	260495	65	90	93,0	62	40	-
K1-67-DSK	260496	67	92	96,0	62	40	-
K1-70-DSK	260497	70	92	100,0	62	40	-
K1-75-DSK	260498	75	98	106,0	86	42	-
K1-76-DSK	260499	76	100	107,0	86	45	-
K1-77-DSK	260500	77	100	109,0	86	45	-
K1-78-DSK	260501	78	100	110,0	86	45	-
K1-80-DSK	260502	80	100	112,0	86	45	-
K1-85-DSK	260503	85	105	118,0	86	52	-
K1-90-DSK	260504	90	105	125,0	86	52	-
K1-95-DSK	260505	95	105	131,0	86	52	-
K1-100-DSK	260506	100	110	137,0	86	58	-
K1-105-DSK	260507	105	110	143,0	95	58	-
K1-110-DSK	260508	110	115	149,0	95	62	-
K1-115-DSK	260509	115	115	155,0	95	62	-



Doppelsechskant – tief

Modell	Best.-Nr.	SW mm	L mm	D1 mm	D2 mm	L2 mm	VE
K1-16-DSKL	260550	16	100	32,0	54	11	-
K1-17-DSKL	260551	17	100	34,0	54	11	-
K1-18-DSKL	260552	18	100	35,0	54	13	-
K1-19-DSKL	260553	19	100	36,0	54	13	-
K1-20-DSKL	260554	20	100	37,0	54	13	-
K1-21-DSKL	260555	21	100	38,0	54	15	-
K1-22-DSKL	260556	22	100	39,0	54	15	-
K1-23-DSKL	260557	23	100	40,0	54	15	-
K1-24-DSKL	260558	24	100	41,0	54	18	-
K1-25-DSKL	260559	25	100	43,0	54	18	-
K1-26-DSKL	260560	26	100	44,5	54	18	-
K1-27-DSKL	260561	27	100	45,0	54	19	-

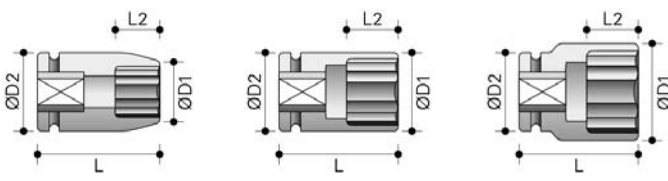

Doppelsechskant – tief

Modell	Best.-Nr.	SW mm	L mm	D1 mm	D2 mm	L2 mm	VE
K1-28-DSKL	260562	28	100	46,5	54	19	-
K1-29-DSKL	260563	29	100	48,0	54	19	-
K1-30-DSKL	260564	30	100	50,0	54	21	-
K1-31-DSKL	260565	31	100	51,0	54	21	-
K1-32-DSKL	260566	32	100	52,0	54	22	-
K1-33-DSKL	260567	33	100	53,0	54	22	-
K1-34-DSKL	260568	34	100	55,0	54	22	-
K1-35-DSKL	260569	35	100	56,0	54	22	-
K1-36-DSKL	260570	36	100	57,0	54	24	-
K1-37-DSKL	260571	37	100	59,0	54	24	-
K1-38-DSKL	260572	38	100	60,0	54	24	-
K1-39-DSKL	260573	39	100	61,0	54	24	-
K1-40-DSKL	260574	40	100	62,0	54	24	-
K1-41-DSKL	260575	41	100	63,5	54	27	-
K1-42-DSKL	260576	42	100	65,0	54	27	-
K1-43-DSKL	260577	43	100	66,0	54	27	-
K1-44-DSKL	260578	44	100	67,0	54	27	-
K1-45-DSKL	260579	45	100	68,0	54	27	-
K1-46-DSKL	260580	46	100	70,0	58	30	-
K1-47-DSKL	260581	47	100	71,5	58	30	-
K1-48-DSKL	260582	48	100	72,5	58	30	-
K1-50-DSKL	260583	50	100	75,0	62	32	-
K1-51-DSKL	260584	51	100	76,0	62	32	-
K1-52-DSKL	260585	52	100	77,0	62	32	-
K1-53-DSKL	260586	53	100	78,0	62	32	-
K1-54-DSKL	260587	54	100	80,0	62	32	-
K1-55-DSKL	260588	55	100	81,0	62	35	-
K1-56-DSKL	260589	56	105	82,0	62	35	-
K1-57-DSKL	260590	57	105	84,0	62	35	-
K1-58-DSKL	260591	58	105	85,0	62	37	-
K1-60-DSKL	260592	60	120	87,0	62	37	-
K1-62-DSKL	260593	62	120	89,0	62	37	-
K1-63-DSKL	260594	63	120	90,0	62	37	-
K1-65-DSKL	260595	65	125	93,0	62	40	-
K1-67-DSKL	260596	67	125	96,0	62	40	-
K1-70-DSKL	260597	70	125	100,0	62	40	-
K1-75-DSKL	260598	75	135	106,0	86	42	-
K1-76-DSKL	260599	76	135	107,0	86	45	-
K1-77-DSKL	260600	77	135	109,0	86	45	-
K1-78-DSKL	260601	78	135	110,0	86	45	-
K1-80-DSKL	260602	80	135	112,0	86	45	-
K1-85-DSKL	260603	85	140	118,0	86	52	-
K1-90-DSKL	260604	90	140	125,0	86	52	-
K1-95-DSKL	260605	95	140	131,0	86	52	-
K1-100-DSKL	260606	100	140	137,0	86	58	-
K1-105-DSKL	260607	105	155	143,0	95	58	-
K1-110-DSKL	260608	110	155	149,0	95	62	-
K1-115-DSKL	260609	115	155	155,0	95	62	-

1 Kraftsteckschlüssel mit 1" Vierkantantrieb nach DIN 3121 H 25



Halter & auswechselbare Einsätze

Modell	Best.-Nr.	SW mm	L mm	D1 mm	D2 mm	T mm	VE
K1-AWE22	260750	22	70	44,0	54	-	-
AWE22-A14	260810	14	50	-	-	-	-
AWE22-A17	260811	17	50	-	-	-	-
AWE22-A19	260812	19	50	-	-	-	-
AWE22-A22	260813	22	50	-	-	-	-
AWE22-A24	260814	24	50	-	-	-	-
AWE22-A27	260815	27	50	-	-	-	-
AWE22-A30	260816	30	50	-	-	-	-
AWE22-A32	260817	32	50	-	-	-	-
AWE22-A36	260818	36	50	-	-	-	-



Innensechskant Inbus® – normal

Modell	Best.-Nr.	SW mm	L mm	D1 mm	D2 mm	L1 mm	VE
K1-A14	260649	14	75	-	54	12	-
K1-A17	260650	17	75	-	54	15	-
K1-A19	260651	19	75	-	54	17	-
K1-A22	260652	22	75	-	54	20	-
K1-A24	260653	24	75	-	54	20	-
K1-A27	260654	27	75	-	54	20	-
K1-A30	260655	30	75	-	54	20	-
K1-A32	260656	32	75	-	54	20	-
K1-A36	260657	36	75	-	54	20	-



Innensechskant Inbus® – tief

Modell	Best.-Nr.	SW mm	L mm	D1 mm	D2 mm	L1 mm	VE
K1-A10-L	260710	10	100	-	54	20	-
K1-A12-L	260711	12	100	-	54	20	-
K1-A14-L	260712	14	100	-	54	20	-
K1-A17-L	260713	17	100	-	54	20	-
K1-A19-L	260714	19	100	-	54	20	-
K1-A22-L	260715	22	100	-	54	20	-
K1-A24-L	260717	24	100	-	54	20	-
K1-A27-L	260718	27	100	-	54	20	-
K1-A30-L	260719	30	100	-	54	24	-
K1-A32-L	260720	32	100	-	54	24	-
K1-A36-L	260722	36	100	-	54	28	-
K1-A22-EL	260716	22	140	-	54	20	-



Gummiring & Sicherungsstift

Modell	Best.-Nr.	Größe Zoll	-	D1 mm	D2 mm	-	VE
RS-1	260850	1	-	-	54	-	5
D01100-0-086	260851	1	-	-	86	-	5
D01100-0-095	260852	1	-	-	95	-	5

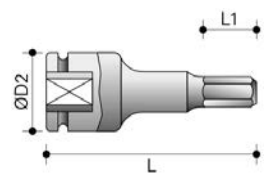

Weitere Infos auf unserer Website.

24/7

1.5 Kraftsteckschlüssel mit 1,5" Vierkantantrieb nach DIN 3121 H 40



Sechskant – normal

Modell	Best.-Nr.	SW mm	L mm	D1 mm	D2 mm	L2 mm	VE
K1.1/2-30	270010	30	78	56	86	21	-
K1.1/2-32	270011	32	78	58	86	22	-
K1.1/2-35	270012	35	78	62	86	22	-
K1.1/2-36	270013	36	78	64	86	24	-
K1.1/2-37	270014	37	78	65	86	24	-
K1.1/2-38	270015	38	78	66	86	26	-
K1.1/2-40	270016	40	78	68	86	28	-
K1.1/2-41	270017	41	80	70	86	28	-
K1.1/2-45	270019	45	84	75	86	30	-
K1.1/2-46	270020	46	84	76	86	30	-
K1.1/2-47	270021	47	84	77	86	32	-
K1.1/2-48	270022	48	84	79	86	32	-
K1.1/2-50	270023	50	87	81	86	32	-
K1.1/2-52	270024	52	87	83	86	34	-
K1.1/2-54	270025	54	90	86	86	37	-
K1.1/2-55	270026	55	90	86	86	37	-
K1.1/2-56	270027	56	92	86	86	37	-
K1.1/2-58	270028	58	92	92	86	39	-
K1.1/2-60	270029	60	92	93	86	39	-
K1.1/2-61	270030	61	95	95	86	42	-
K1.1/2-62	270031	62	95	96	86	42	-
K1.1/2-65	270032	65	95	97	86	42	-
K1.1/2-68	270033	68	100	104	86	46	-
K1.1/2-70	270034	70	100	105	86	46	-
K1.1/2-72	270035	72	108	108	86	49	-
K1.1/2-75	270036	75	108	110	86	49	-
K1.1/2-78	270037	78	115	115	86	53	-
K1.1/2-80	270038	80	115	116	86	53	-
K1.1/2-85	270039	85	118	125	86	56	-
K1.1/2-90	270040	90	123	130	86	59	-
K1.1/2-95	270041	95	123	137	95	62	-
K1.1/2-100	270042	100	130	140	95	65	-
K1.1/2-105	270043	105	130	150	95	68	-
K1.1/2-110	270044	110	135	156	95	72	-
K1.1/2-115	270045	115	140	160	95	77	-
K1.1/2-125	270047	125	140	175	127	77	-



Sechskant – tief

Modell	Best.-Nr.	SW mm	L mm	D1 mm	D2 mm	L2 mm	VE
K1.1/2-36-L	270109	36	115	64	86	24	-
K1.1/2-41-L	270110	41	115	70	86	28	-
K1.1/2-42-L	270111	42	115	71	86	28	-
K1.1/2-46-L	270112	46	115	76	86	30	-
K1.1/2-50-L	270113	50	135	81	86	34	-
K1.1/2-54-L	270114	54	140	86	86	37	-
K1.1/2-55-L	270115	55	140	86	86	37	-
K1.1/2-56-L	270132	56	140	88	86	37	-
K1.1/2-60-L	270116	60	150	94	86	39	-
K1.1/2-63-L	270117	63	150	97	86	42	-
K1.1/2-65-L	270118	65	150	100	86	42	-
K1.1/2-70-L	270119	70	160	106	86	46	-
K1.1/2-75-L	270120	75	170	112	86	49	-
K1.1/2-80-L	270121	80	170	119	86	53	-
K1.1/2-85-L	270122	85	170	125	86	56	-
K1.1/2-90-L	270123	90	175	131	86	59	-
K1.1/2-95-L	270124	95	180	137	95	61	-
K1.1/2-100-L	270125	100	190	144	95	65	-
K1.1/2-105-L	270126	105	190	154	95	68	-
K1.1/2-110-L	270127	110	200	157	95	72	-
K1.1/2-115-L	270128	115	210	164	95	77	-
K1.1/2-120-L	270129	120	210	167	95	77	-
K1.1/2-125-L	270130	125	210	174	127	77	-

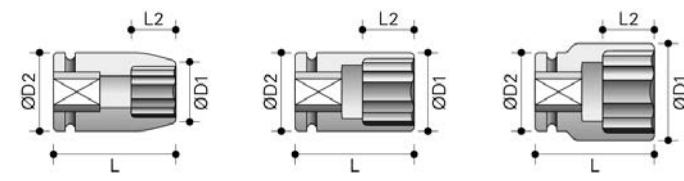

Weitere Infos auf unserer Website.

24/7

1.5 Kraftsteckschlüssel mit 1,5" Vierkantantrieb nach DIN 3121 H 40



Innensechskant Inbus® – normal

Modell	Best.-Nr.	SW mm	L mm	D1 mm	D2 mm	L1 mm	VE
K1.1/2-A19	270158	19	105	-	86	20	-
K1.1/2-A22	270159	22	105	-	86	20	-
K1.1/2-A24	270160	24	105	-	86	20	-
K1.1/2-A27	270161	27	105	-	86	20	-
K1.1/2-A30	270162	30	105	-	86	20	-
K1.1/2-A32	270163	32	105	-	86	20	-
K1.1/2-A33	270164	33	105	-	86	20	-
K1.1/2-A41	270157	41	105	-	86	20	-
K1.1/2-A46	270165	46	105	-	86	20	-
K1.1/2-A50	270166	50	105	-	86	20	-
K1.1/2-A55	270167	55	105	-	86	20	-

Gummiring & Sicherungsstift

Modell	Best.-Nr.	Größe Zoll	-	D1 mm	D2 mm	-	VE
RS-1.1/2	270210	1 1/2	-	-	86	-	5
D01112-0-095	270211	1 1/2	-	-	95	-	5
D01112-0-127	270212	1 1/2	-	-	127	-	5



Innensechskant Inbus® – tief

Modell	Best.-Nr.	SW mm	L mm	D1 mm	D2 mm	L1 mm	VE
K1.1/2-A19-L	270150	19	120	-	86	20	-
K1.1/2-A22-L	270151	22	120	-	86	20	-
K1.1/2-A24-L	270152	24	120	-	86	20	-
K1.1/2-A27-L	270153	27	120	-	86	20	-
K1.1/2-A30-L	270154	30	120	-	86	24	-
K1.1/2-A32-L	270155	32	120	-	86	24	-
K1.1/2-A33-L	270168	33	120	-	86	24	-
K1.1/2-A36-L	270156	36	120	-	86	28	-
K1.1/2-A38-L	270169	38	120	-	86	28	-
K1.1/2-A41-L	270170	41	120	-	86	34	-
K1.1/2-A46-L	270171	46	120	-	86	38	-
K1.1/2-A50-L	270172	50	120	-	86	38	-
K1.1/2-A55-L	270173	55	120	-	86	43	-

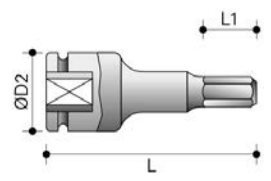

Weitere Infos auf unserer Website.  24/7

2.5 Kraftsteckschlüssel mit 2,5" Vierkantantrieb nach DIN 3121 H 63



Sechskant – normal

Modell	Best.-Nr.	SW mm	L mm	D1 mm	D2 mm	L2 mm	VE
K2.1/2-60	280010	60	125	99	127	37	-
K2.1/2-65	280011	65	130	105	127	40	-
K2.1/2-70	280012	70	130	110	127	40	-
K2.1/2-75	280013	75	140	118	127	42	-
K2.1/2-80	280015	80	140	124	127	45	-
K2.1/2-85	280016	85	140	130	127	52	-
K2.1/2-90	280017	90	145	136	127	52	-
K2.1/2-95	280018	95	145	143	127	52	-
K2.1/2-100	280019	100	150	149	127	58	-
K2.1/2-105	280020	105	155	155	127	58	-
K2.1/2-110	280021	110	160	161	127	60	-
K2.1/2-115	280022	115	165	167	127	62	-
K2.1/2-120	280023	120	170	176	127	67	-
K2.1/2-125	280024	125	175	184	127	72	-
K2.1/2-130	280025	130	175	188	152	72	-
K2.1/2-135	280026	135	180	195	152	77	-
K2.1/2-140	280027	140	180	204	152	77	-
K2.1/2-145	280028	145	185	207	152	83	-
K2.1/2-150	280029	150	185	214	152	83	-
K2.1/2-155	280030	155	190	224	152	90	-
K2.1/2-160	280031	160	190	227	152	90	-
K2.1/2-165	280032	165	195	234	152	95	-
K2.1/2-170	280033	170	195	244	152	95	-
K2.1/2-175	280034	175	200	247	152	100	-
K2.1/2-180	280035	180	200	254	152	100	-
K2.1/2-185	280036	185	210	257	152	105	-
K2.1/2-190	280037	190	210	265	152	105	-
K2.1/2-200	280038	200	220	275	152	110	-

Gummiring & Sicherungsstift

Modell	Best.-Nr.	Größe Zoll	-	D1 mm	D2 mm	-	VE
RS-2.1/2	280050	2 1/2	-	-	-	-	5

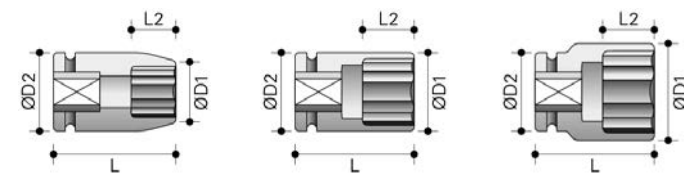

Weitere Infos auf unserer Website.  24/7



Kraftsteckschlüssel – Sets

3/8



13-teilig – Sechskant – tief

Modell	Best.-Nr.	SW [mm]
KS3/8-13-L	222170	7 - 8 - 9 - 10 - 11 - 12 - 13 - 14 - 15 - 16 - 17 - 18 - 19

3/8



13-teilig – Sechskant – dünnwandig

Modell	Best.-Nr.	SW [mm]
KS3/8-13-DW	222180	7 - 8 - 9 - 10 - 11 - 12 - 13 - 14 - 15 - 16 - 17 - 18 - 19

1/2



10-teilig – Sechskant – normal

Modell	Best.-Nr.	SW [mm]
KS1/2-10	231710	9 - 10 - 11 - 13 - 14 - 17 - 19 - 22 - 24 - 27

1/2



10-teilig – Sechskant – tief

Modell	Best.-Nr.	SW [mm]
KS1/2-10-L	231720	10 - 11 - 13 - 14 - 17 - 19 - 21 - 22 - 24 - 27

1/2



26-teilig – Sechskant – normal

Modell	Best.-Nr.	SW [mm]
KS1/2-26	231726	10 - 11 - 12 - 13 - 14 - 15 - 16 - 17 - 18 - 19 - 20 - 21 - 22 - 23 - 24 - 25 - 26 - 27 - 28 - 29 - 30 - 32 - 33 - 34 - 35 - 36

1/2



26-teilig – Sechskant – tief

Modell	Best.-Nr.	SW [mm]
KS1/2-26-L	231736	10 - 11 - 12 - 13 - 14 - 15 - 16 - 17 - 18 - 19 - 20 - 21 - 22 - 23 - 24 - 25 - 26 - 27 - 28 - 29 - 30 - 32 - 33 - 34 - 35 - 36

1/2



26-teilig – Zwölfkant – tief

Modell	Best.-Nr.	SW [mm]
KS1/2-26-DS	231729	10 - 11 - 12 - 13 - 14 - 15 - 16 - 17 - 18 - 19 - 20 - 21 - 22 - 23 - 24 - 25 - 26 - 27 - 28 - 29 - 30 - 32 - 33 - 34 - 35 - 36



Kraftsteckschlüssel – Sets

1/2



9-teilig – Innensechskant (Inbus®)

Modell	Best.-Nr.	SW [mm]
KS1/2-A-9	231716	4 - 5 - 6 - 8 - 10 - 12 - 14 - 17 - 19

1/2



7-teilig – Innenvielzahn (XZN)

Modell	Best.-Nr.	Größe #
KS1/2-XZ-7	231719	M5 - M6 - M8 - M10 - M12 - M14 - M16

1/2



13-teilig – Schnellwechsler & 7/16 Biteinsätze

Modell	Best.-Nr.	Inbus® [mm]	Torx® #
KS1/2-13-7/16	231739	6 - 8 - 10 - 12 - 14 - 17	T30 - T40 - T45 - T50 - T55 - T60

3/4



10-teilig – Sechskant – normal

Modell	Best.-Nr.	SW [mm]
KS3/4-10	251010	21 - 22 - 24 - 27 - 30 - 32 - 33 - 36 - 41 - 46

3/4



10-teilig – Sechskant – tief

Modell	Best.-Nr.	A/F [mm]
KS3/4-10-L	251020	21 - 22 - 24 - 27 - 30 - 32 - 33 - 36 - 41 - 46

1/1



7-teilig – Sechskant – tief

Modell	Best.-Nr.	SW [mm]
KS1-7-L	261010	24 - 27 - 30 - 32 - 33 - 36 - 41



Verbindungssteile mit Vierkantantrieb nach DIN 3121 G



Kraftverlängerung – mit Stiftloch *

Modell	Best.-Nr.	4kt Zoll	L mm	D2 mm	VE
KV1/4-50	313110	1/4	50	13	-
KV1/4-100	313111	1/4	100	13	-
KV1/4-150	313112	1/4	150	13	-
KV3/8-75	313113	3/8	75	19	-
KV3/8-100	313114	3/8	100	19	-
KV3/8-125	313115	3/8	125	19	-
KV3/8-150	313116	3/8	150	19	-
KV3/8-200	313117	3/8	200	19	-
KV3/8-250	313118	3/8	250	19	-
KV1/2-75	313119	1/2	75	25	-
KV1/2-100	313120	1/2	100	25	-
KV1/2-125	313121	1/2	125	25	-
KV1/2-150	313122	1/2	150	25	-
KV1/2-175	313123	1/2	175	25	-
KV1/2-250	313124	1/2	250	25	-
KV1/2-300	313125	1/2	300	25	-
KV1/2-460	313126	1/2	460	25	-
KV1/2-610	313127	1/2	610	25	-
KV1/2-915	313128	1/2	915	25	-
KV3/4-75	313129	3/4	75	44	-
KV3/4-100	313130	3/4	100	44	-
KV3/4-125	313131	3/4	125	44	-
KV3/4-150	313132	3/4	150	44	-
KV3/4-175	313133	3/4	175	44	-
KV3/4-200	313134	3/4	200	44	-
KV3/4-250	313135	3/4	250	44	-
KV3/4-330	313137	3/4	330	44	-
KV3/4-400	313138	3/4	400	44	-
KV1-75	313139	1	75	54	-
KV1-100	313140	1	100	54	-
KV1-125	313141	1	125	54	-
KV1-150	313142	1	150	54	-
KV1-175	313143	1	175	54	-
KV1-200	313144	1	200	54	-
KV1-250	313145	1	250	54	-
KV1-300	313146	1	300	54	-
KV1-330	313147	1	330	54	-
KV1-350	313149	1	350	54	-
KV1-400	313148	1	400	54	-
KV1.1/2-125	313158	1.1/2	125	86	-
KV1.1/2-175	313150	1.1/2	175	86	-
KV1.1/2-250	313151	1.1/2	250	86	-
KV1.1/2-500	313153	1.1/2	500	86	-
KV2.1/2-250	313155	2.1/2	250	127	-
KV2.1/2-500	313157	2.1/2	500	127	-

Gummiring und Sicherungsstift

Modell	Best.-Nr.	Größe Zoll	-	D1 mm	D2 mm	-	VE
RS-1/4	210950	1/4	-	-	13	-	5
RS-3/8	222050	3/8	-	-	13	-	5
RS-1/2	240510	1/2	-	-	-	-	5
RS-3/4	250810	3/4	-	-	-	-	5
RS-1	260850	1	-	-	54	-	5
RS-1.1/2	270210	1 1/2	-	-	-	-	5
RS-2.1/2	280050	2 1/2	-	-	-	-	5



Kraftverlängerung – mit Federstift

Modell	Best.-Nr.	4kt Zoll	L mm	D2 mm	VE
KV1/4-FS-50	313010	1/4	50	13	-
KV1/4-FS-150	313011	1/4	150	13	-
KV1/4-FS-200	313022	1/4	200	13	-
KV3/8-FS-50	313012	3/8	50	19	-
KV3/8-FS-75	313013	3/8	75	19	-
KV3/8-FS-100	313023	3/8	100	19	-
KV3/8-FS-125	313024	3/8	125	19	-
KV3/8-FS-150	313014	3/8	150	19	-
KV3/8-FS-200	313015	3/8	200	19	-
KV3/8-FS-250	313025	3/8	250	19	-
KV3/8-FS-300	313016	3/8	300	19	-
KV1/2-FS-50	313017	1/2	50	25	-
KV1/2-FS-75	313018	1/2	75	25	-
KV1/2-FS-100	313027	1/2	100	25	-
KV1/2-FS-125	313019	1/2	125	25	-
KV1/2-FS-150	313028	1/2	150	25	-
KV1/2-FS-175	313020	1/2	175	25	-
KV1/2-FS-200	313029	1/2	200	25	-
KV1/2-FS-250	313021	1/2	250	25	-
KV1/2-FS-460	313030	1/2	460	25	-

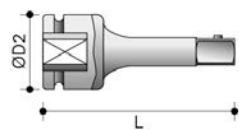
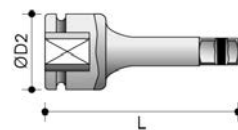

* Ring+Stift nicht enthalten, bitte ggf. separat bestellen.

Weitere Infos auf unserer Website.



24/7

Verbindungssteile mit Vierkantantrieb nach DIN 3121 G



Kraftverlängerung – mit Kugelsicherung

Modell	Best.-Nr.	4kt Zoll	L mm	D2 mm	VE
KV3/8-KS-75	313050	3/8	75	19	-
KV3/8-KS-100	313051	3/8	100	19	-
KV3/8-KS-125	313052	3/8	125	19	-
KV3/8-KS-150	313053	3/8	150	19	-
KV3/8-KS-250	313054	3/8	250	19	-
KV1/2-KS-75	313055	1/2	75	25	-
KV1/2-KS-100	313056	1/2	100	25	-
KV1/2-KS-125	313057	1/2	125	25	-
KV1/2-KS-250	313058	1/2	250	25	-

Kraftverlängerung – „Wobble“

Modell	Best.-Nr.	4kt Zoll	L mm	D2 mm	VE
KV1/4-W-50	313070	1/4	50	13	-
KV1/4-W-75	313071	1/4	75	13	-
KV1/4-W-100	313072	1/4	100	13	-
KV3/8-W-50	313080	3/8	50	19	-
KV3/8-W-75	313081	3/8	75	19	-
KV3/8-W-100	313082	3/8	100	19	-
KV3/8-W-200	313084	3/8	200	19	-
KV1/2-W-75	313090	1/2	75	25	-
KV1/2-W-125	313091	1/2	125	25	-
KV1/2-W-150	313092	1/2	150	25	-
KV1/2-W-200	313093	1/2	200	25	-



Die „Wobble“-Verlängerung hat eine spezielle Geometrie am Abtriebsvierkant. Dies erlaubt dem Anwender, einen Ausschwenkwinkel von bis zu 15° zwischen der Kraftnuss und der Verlängerung zu nutzen. Dadurch sind viele sonst schwer zugängliche Verschraubungen leicht und sicher zu erreichen.

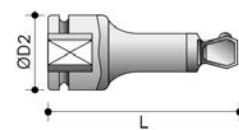
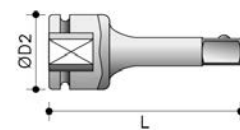

Weitere Infos auf unserer Website.

24/7

Verbindungssteile mit Vierkantantrieb nach DIN 3121 G



Reduzieradapter* – mit Stiftloch

Modell	Best.-Nr.	E Zoll	A Zoll	L mm	D2 mm	VE
KR1/4-3/8	313310	1/4	3/8	26	13	-
KR3/8-1/4	313326	3/8	1/4	32	22	-
KR3/8-1/2	313311	3/8	1/2	36	22	-
KR1/2-3/8	313312	1/2	3/8	38	26	-
KR1/2-3/4	313313	1/2	3/4	48	30	-
KR3/4-1/2	313314	3/4	1/2	58	40	-
KR3/4-1	313316	3/4	1"	63	40	-
KR1-1/2	313318	1"	1/2	70	54	-
KR1-3/4	313319	1"	3/4	75	54	-
KR1-3/4-L	313320	1"	3/4	80	52	-
KR1-1.1/2	313321	1"	1.1/2	91	52	-
KR1.1/2-1	313323	1.1/2	1"	95	84	-
KR1.1/2-2.1/2	313325	1.1/2	2.1/2	120	86	-
KR1.3/4-1.1/2	313327	1.3/4	1.1/2	153	127	-
KR2.1/2-1.1/2	313328	2.1/2	1.1/2	138	127	-

Ring+Stift nicht enthalten, bitte ggf. separat bestellen.



Reduzieradapter* – mit Kugelsicherung

Modell	Best.-Nr.	E Zoll	A Zoll	L mm	D2 mm	VE
KR1/4-3/8-KS	313253	1/4	3/8	26	13,6	-
KR3/8-1/4-KS	313254	3/8	1/4	32	22	-
KR3/8-1/2-KS	313251	3/8	1/2	36	22	-
KR1/2-3/8-KS	313250	1/2	3/8	38	25	-
KR1/2-3/4-KS	313255	1/2	3/4	48	30	-
KR3/4-1/2-KS	313252	3/4	1/2	56	44	-
KR3/4-1-KS	313256	3/4	1	75	54	-
KR1-3/4-KS	313527	1"	3/4	75	54	-

Reduzieradapter* – mit Federstift

Modell	Best.-Nr.	E Zoll	A Zoll	L mm	D2 mm	VE
KR1/4-3/8-FS	313210	1/4	3/8	26	13	-
KR3/8-1/4-FS	313211	3/8	1/4	32	19	-
KR3/8-1/2-FS	313212	3/8	1/2	36	22	-
KR1/2-1/4-FS	313213	1/2	1/4	35	25	-
KR1/2-3/8-FS	313214	1/2	3/8	38	25	-
KR1/2-3/4-FS	313215	1/2	3/4	48	30	-
KR5/8-1/2-FS	313216	5/8	1/2	46	35	-
KR5/8-3/4-FS	313217	5/8	3/4	70	35	-



Reduzieradapter* – mit Magnet

Modell	Best.-Nr.	E Zoll	A Zoll	L mm	D2 mm	VE
KRM1/4-3/8	313270	1/4	3/8	17	19	-
KRM1/4-1/2	313271	1/4	1/2	22	25	-
KRM3/8-1/2	313272	3/8	1/2	22	25	-
KRM1/2-5/8	313273	1/2	5/8	23	35	-
KRM1/2-3/4	313274	1/2	3/4	30	44	-
KRM3/4-1	313275	3/4	1"	35	54	-
KRM1-1.1/2	313276	1"	1.1/2	50	86	-
KRM1.1/2-2.1/2	313277	1.1/2	2.1/2	59	127	-
KRM2.1/2-3.1/2	313278	2.1/2	3.1/2	95	176	-
KRM-SET4	313290	1/4	3/8	17	19	-
		3/8	1/2	22	25	-
		1/2	3/4	30	44	-
		3/4	1	35	54	-

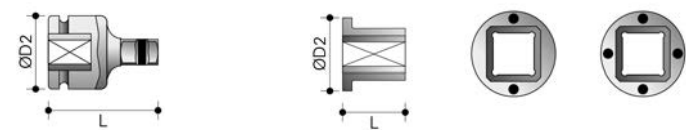

* von der Herstellergarantie ausgenommen.

Weitere Infos auf unserer Website.



Verbindungssteile mit Vierkantantrieb nach DIN 3121 G



Kugelgelenk* – mit Stiftloch

Modell	Best.-Nr.	4kt Zoll	L mm	D1 mm	D2 mm	T mm	VE
KG1/4	313450	1/4	43	-	16	-	-
KG3/8	313451	3/8	50	-	24	-	-
KG1/2	313452	1/2	60	-	32	-	-
KG3/4	313458	3/4	90	-	44	-	-
KG3/4-L	313453	3/4	105	-	44	-	-
KG1	313455	1	110	-	54	-	-
KG1.1/2	313456	1 1/2	182	-	86	-	-

Ring+Stift nicht enthalten, bitte ggf. separat bestellen.



Gummiring & Sicherungsstift

Modell	Best.-Nr.	Größe Zoll	-	D1 mm	D2 mm	-	VE
RS-1/4	210950	1/4	-	-	13	-	5
RS-3/8	222050	3/8	-	-	13	-	5
RS-1/2	240510	1/2	-	-	-	-	5
RS-3/4	250810	3/4	-	-	-	-	5
RS-1	260850	1"	-	-	54	-	5
RS-1.1/2	270210	1 1/2	-	-	-	-	5
RS-2.1/2	280050	2 1/2	-	-	-	-	5

Kugelgelenk* – mit Kugelsicherung

Modell	Best.-Nr.	4kt Zoll	L mm	D1 mm	D2 mm	T mm	VE
KG1/4-KS	313410	1/4	43	-	16	-	-
KG3/8-KS	313411	3/8	50	-	24	-	-
KG1/2-KS	313412	1/2	60	-	32	-	-
KG3/4-KS	313413	3/4	90	-	44	-	-



Kugelgelenk* – mit Federstift

Modell	Best.-Nr.	4kt Zoll	L mm	D1 mm	D2 mm	T mm	VE
KG1/4-FS	313350	1/4	45	18	13	-	-
KG3/8-FS	313351	3/8	60	25	22	-	-
KG1/2-FS	313353	1/2	68	31	25	-	-
KG1/2-FS	313355	1/2	150	30	25	-	-

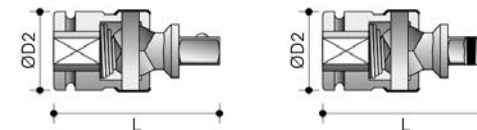

* von der Herstellergarantie ausgenommen.



Weitere Infos auf unserer Website.

E-Mail: info@zemo-tools.de • Tel.: +49 (0)40 303 989 100 • Web: www.zemo-tools.de

Verbindungssteile mit Vierkanttrieb nach DIN 3121 G



Schnellwechselhalter (A) – mit Kugelsicherung

Modell	Best.-Nr.	E Zoll	A Zoll	L mm	D1 mm	D2 mm	VE
KQC1/4-1/4	313510	1/4	1/4	35	-	13	-
KQC1/4-3/8	313530	1/4	3/8	42	-	13	-
KQC3/8-3/8	313511	3/8	3/8	46	-	19	-
KQC3/8-1/2	313517	3/8	1/2	60	-	22	-
KQC1/2-3/8	313512	1/2	3/8	54	-	25	-
KQC1/2-1/2	313513	1/2	1/2	60	-	25	-
KQC3/4-1/2	313518	3/4	1/2	70	-	44	-
KQC3/4-3/4	313514	3/4	3/4	78	-	44	-
KQC1-3/4	313515	1	3/4	90	-	54	-
KQC1-3/4	313519	1	3/4	300	-	54	-
KQC1-1	313516	1	1	100	-	54	-

Schnellwechsel-Bithalter – mit Sprengring

Modell	Best.-Nr.	E Zoll	A Zoll	L mm	D1 mm	D2 mm	VE
KQC3/8-1/4-D	313557	3/8	1/4	33	-	19	-
KQC1/2-1/4-D	313558	1/2	1/4	41	-	25	-



Schnellwechsel-Bithalter – mit Kugelsicherung

Modell	Best.-Nr.	E Zoll	A Zoll	L mm	D1 mm	D2 mm	VE
KQC3/8-1/4-F	313574	3/8	1/4	45	-	19	-
KQC3/8-7/16-F	313573	3/8	7/16	51	-	22	-
KQC1/2/7/16-F	313572	1/2	7/16	54	-	25	-

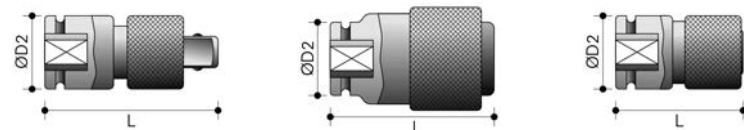

Verbindungssteile mit Vierkanttrieb nach DIN 3121 G



Bitadapter – kurz – mit Sprengring

Modell	Best.-Nr.	4kt Zoll	6kt Zoll	L mm	D1 mm	D2 mm	VE
KVT3/8-D6.3-32	313613	3/8	1/4	32	12,5	19	-
KVT3/8-D8	313614	3/8	5/16	37	14	19	-
KVT3/8-H12.5	313615	3/8	1/2	37	19	19	-
KVT1/2-D6.3	313616	1/2	1/4	40	12,5	25	-
KVT1/2-D8	313617	1/2	5/16	40	15,5	25	-
KVT1/2-H12.5	313618	1/2	1/2	40	20	25	-

Bitadapter – tief

Modell	Best.-Nr.	4kt Zoll	6kt Zoll	L mm	D1 mm	D2 mm	VE
KVT1/4-D6.3-L	313625	1/4	1/4	75	-	13	-
KVT3/8-D6.3-L	313626	3/8	1/4	75	-	19	-
KVT3/8-D8-L	313686	3/8	5/16	75	-	19	-
KVT1/2-D6.3-L	313627	1/2	1/4	75	-	25	-
KVT1/2-D8-L	313687	1/2	5/16	75	-	25	-



Bitadapter – tief – mit Magnet

Modell	Best.-Nr.	4kt Zoll	6kt Zoll	L mm	D1 mm	D2 mm	VE
KMVT1/4-D6.3-L	313650	1/4	1/4	75	-	13	-
KMVT3/8-D6.3-L	313651	3/8	1/4	75	-	19	-

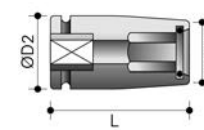

Weitere Infos auf unserer Website.
24/7





Nutsetter nach DIN 7424 – mit Sechskantantrieb E 6.3 *



Antrieb E 6,3 – Sechskant

Modell	Best.-Nr.	SW	L mm	L1 mm	D1 mm	VE
NR4.5-E6.3-50	117210	4,5	50	3,0	7,7	5
NR5-E6.3-50	117211	5	50	4,0	8,4	5
NR5.5-E6.3-50	117212	5,5	50	4,0	9,0	5
NR6-E6.3-50	117213	6	50	4,5	10,0	5
NR1/4-E6.3-50	117222	1/4"	50	5,0	10,0	5
NR7-E6.3-50	117214	7	50	5,0	11,0	5
NR8-E6.3-50	117215	8	50	6,0	13,0	5
NR9-E6.3-50	117216	9	50	7,0	14,0	5
NR3/8-E6.3-50	117223	3/8"	50	7,0	14,2	5
NR10-E6.3-50	117217	10	50	7,0	14,2	5
NR11-E6.3-50	117218	11	50	8,0	16,0	5
NR12-E6.3-50	117219	12	50	8,0	17,0	5
NR13-E6.3-50	117220	13	50	8,0	18,0	5
NR14-E6.3-50	117221	14	50	9,0	19,0	5
NR4-E6.3-55	117050	4	55	4,5	8	5
NR6-E6.3-55	117052	6	55	4,5	10	5
NR7-E6.3-55	117053	7	55	5,0	11	5
NR8-E6.3-55	117054	8	55	5,0	12	5
NR10-E6.3-55	117056	10	55	6,5	14	5
NR4.5-E6.3-65	117410	4,5	65	3,0	7,7	5
NR5-E6.3-65	117411	5	65	4,0	8,4	5
NR5.5-E6.3-65	117412	5,5	65	4,0	9,0	5
NR6-E6.3-65	117413	6	65	5,0	5,2	5
NR1/4-E6.3-65	117421	1/4"	65	5,0	5,2	5
NR7-E6.3-65	117414	7	65	5,0	11,5	5
NR8-E6.3-65	117415	8	65	6,0	12,7	5
NR3/8-E6.3-65	117422	3/8"	65	7,0	14,5	5
NR10-E6.3-65	117417	5	65	7,0	16,0	5
NR13-E6.3-65	117420	13	65	8,0	18,0	5
NR6-E6.3-75	117430	6	75	4,5	5,0	5
NR7-E6.3-75	117431	7	75	4,5	11,0	5
NR8-E6.3-75	117432	8	75	4,5	12,0	5
NR10-E6.3-75	117434	5	75	5,5	14,0	5
NR12-E6.3-75	117436	12	75	5,5	17,0	5
NR13-E6.3-75	117437	13	75	5,5	18,0	5
NR14-E6.3-75	117438	14	75	5,5	19,0	5
NR12-E6.3-200	117442	12	200	5,5	17,0	-
NR14-E6.3-200	117444	14	200	5,5	19,0	-

Antrieb E 6,3 – Sechskant mit Klemmfeder

Modell	Best.-Nr.	SW	L mm	L1 mm	D1 mm	VE
NRKF7-E6.3-50	117610	7	50	5,2	13	5
NRKF8-E6.3-50	117611	8	50	5,2	14	5
NRKF3/8-E6.3-50	117614	3/8"	50	5,2	16	5
NRKF10-E6.3-50	117612	10	50	5,2	16	5

Funktionsprinzip der Klemmfeder

Um nicht magnetisierbare Schrauben – z.B. Nirosa – beim Verschrauben sicher im Werkzeug festzuhalten, wird die benötigte Klemmwirkung durch eine Stahlfeder mit verrundeter Spitze aufgebracht. Durch die Verrundung der andrückenden Federspitze wird die Beschädigung einer aufgetragenen Beschichtung – z.B. Farbe bei Fassadenschrauben – vermieden.

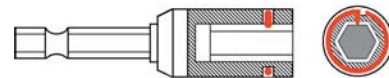

Antrieb E 6,3 – Sechsrund Torx® E

Modell	Best.-Nr.	TX #	L mm	L1 mm	D1 mm	VE
NRE4-E6.3-50	117450	E4	50	3,5	6,5	5
NRE5-E6.3-50	117451	E5	50	4,1	7,7	5
NRE6-E6.3-50	117452	E6	50	4,3	8,7	5
NRE8-E6.3-50	117453	E8	50	6,0	9,7	5
NRE10-E6.3-50	117454	E10	50	7,0	12,2	5

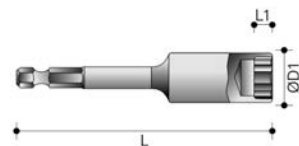

* Für direkten Maschinenanschluss, vgl. Tabelle „Zuordnung von Werkzeugantrieb und Maschine“ S. 72.

Weitere Infos auf unserer Website.



24/7



Nutsetter nach DIN 7424 – mit Sechskantantrieb E 6.3 *

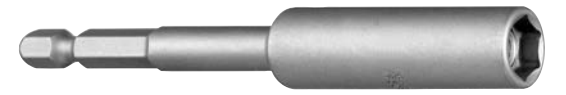

Antrieb E 6,3 – Sechskant mit Magnet

Modell	Best.-Nr.	SW	L mm	L1 mm	D1 mm	VE
NRM4.5-E6.3-50	117310	4,5	50	2,1	7,7	5
NRM5-E6.3-50	117311	5	50	2,1	8,4	5
NRM5.5-E6.3-50	117312	5,5	50	2,1	9,0	5
NRM6-E6.3-50	117313	6	50	2,4	10,0	5
NRM1/4-E6.3-50	117322	1/4"	50	2,8	10,0	5
NRM7-E6.3-50	117314	7	50	2,8	11,0	5
NRM8-E6.3-50	117315	8	50	3,5	13,0	5
NRM9-E6.3-50	117316	9	50	4,0	14,0	5
NRM3/8-E6.3-50	117323	3/8"	50	4,2	14,2	5
NRM10-E6.3-50	117317	10	50	4,2	14,2	5
NRM11-E6.3-50	117318	11	50	4,9	16,0	5
NRM12-E6.3-50	117319	12	50	5,6	17,0	5
NRM13-E6.3-50	117320	13	50	6,0	18,0	5
NRM6-E6.3-55	117150	6	55	4,5	10,0	5
NRM7-E6.3-55	117151	7	55	4,5	11,0	5
NRM8-E6.3-55	117152	8	55	4,5	12,0	5
NRM10-E6.3-55	117154	10	55	5,5	14,0	5
NRM11-E6.3-55	117155	11	55	5,5	16,0	5
NRM12-E6.3-55	117156	12	55	5,5	17,0	5
NRM13-E6.3-55	117157	13	55	5,5	18,0	5
NRM14-E6.3-55	117158	14	55	5,5	19,0	5
NRM5.5-E6.3-65	117512	5,5	65	2,1	9,0	5
NRM6-E6.3-65	117513	6	65	2,4	10,2	5
NRM7-E6.3-65	117514	7	65	2,8	11,5	5
NRM8-E6.3-65	117515	8	65	3,5	12,7	5
NRM3/8-E6.3-65	117522	3/8"	65	4,2	14,2	5
NRM10-E6.3-65	117517	10	65	4,2	14,5	5
NRM13-E6.3-65	117520	13	65	6,0	18,0	5
NRM10-E6.3-75	117550	10	75	5,5	14,0	5
NRM12-E6.3-75	117552	12	75	5,5	17,0	5
NRM6-E6.3-100	117526	6	100	4,5	10,0	-
NRM7-E6.3-100	117523	7	100	4,5	11,0	-
NRM8-E6.3-100	117529	8	100	4,5	12,0	-
NRM10-E6.3-100	117532	10	100	5,5	14,0	-
NRM12-E6.3-100	117535	12	100	5,5	17,0	-
NRM13-E6.3-100	117538	13	100	5,5	18,0	-
NRM14-E6.3-100	117541	14	100	5,5	19,0	-
NRM17-E6.3-100	117544	17	100	5,5	23,0	-
NRM10-E6.3-150	117533	10	150	5,5	14,0	-
NRM7-E6.3-200	117548	7	200	4,5	11,0	-
NRM10-E6.3-200	117534	10	200	5,5	14,0	-

Antrieb E 6,3 – Sechskant mit Federmagnet

Modell	Best.-Nr.	SW mm	L mm	L1 mm	D1 mm	VE
NRFM6-E6.3-75	117700	6	75	4,5	10	5
NRFM6-E6.3-100	117708	6	100	4,5	10	5
NRFM8-E6.3-100	117710	8	100	4,0	14	5
NRFM10-E6.3-100	117711	10	100	5,5	16	5
NRFM12-E6.3-100	117714	12	100	5,5	17	5
NRFM13-E6.3-100	117712	13	100	8,0	19	5
NRFM14-E6.3-100	117715	14	100	5,5	19	5
NRFM6-E6.3-150	117720	6	150	4,5	10	-
NRFM8-E6.3-150	117722	8	150	4,5	12	-
NRFM10-E6.3-150	117724	10	150	5,5	14	-
NRFM12-E6.3-150	117726	12	150	5,5	17	-
NRFM13-E6.3-150	117727	13	150	5,5	18	-
NRFM14-E6.3-150	117728	14	150	5,5	19	-
NRFM6-E6.3-200	117730	6	200	4,5	10	-
NRFM8-E6.3-200	117732	8	200	4,5	12	-
NRFM10-E6.3-200	117734	10	200	5,5	14	-
NRFM12-E6.3-200	117736	12	200	5,5	17	-
NRFM13-E6.3-200	117737	13	200	5,5	18	-
NRFM14-E6.3-200	117738	14	200	5,5	19	-

Funktionsprinzip des federnden Dauermagneten

Beim Anzug einer Schraubenmutter findet der immer weiter ins Werkzeug ragende Gewindebolzen genügend Platz. Der federnd gelagerte Magnet wird durch den Bolzen weiter ins Werkzeug gedrückt, ohne dass sich die Mutter aus dem Werkzeug herauszieht.

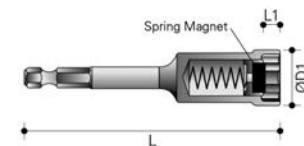
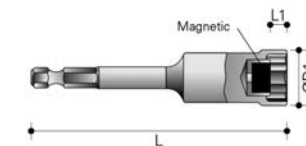
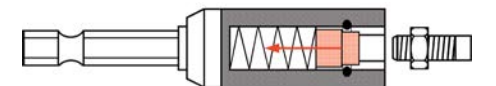

* Für direkten Maschinenanschluss, vgl. Tabelle „Zuordnung von Werkzeugantrieb und Maschine“ S. 72.

Weitere Infos auf unserer Website.



24/7



Vierkant-Adapter – für Schraubendreher/Drehschrauber *



Antrieb C 6,3 – Vierkant mit Federstift

Modell	Best.-Nr.	Antrieb	4kt Zoll	L mm	Ø mm	VE
VK1/4-C6.3-25-FS	118010	C6.3	1/4	25	8	5



Antrieb C 8 – Vierkant mit Federstift

Modell	Best.-Nr.	Antrieb	4kt Zoll	L mm	Ø mm	VE
VK1/4-C8-27-FS	118110	C8	1/4	40	8	5
VK3/8-C8-32-FS	118111	C8	3/8	40	13	5



Antrieb E 6,3 – Vierkant mit Federstift

Modell	Best.-Nr.	Antrieb	4kt Zoll	L mm	Ø mm	VE
VK1/4-E6.3-50-FS	118210	E6.3	1/4	50	9	5
VK1/4-E6.3-75-FS	118211	E6.3	1/4	75	9	5
VK1/4-E6.3-102-FS	118212	E6.3	1/4	100	9	5
VK1/4-E6.3-125-FS	118223	E6.3	1/4	125	9	5
VK1/4-E6.3-152-FS	118213	E6.3	1/4	150	9	5
VK1/4-E6.3-200-FS	118218	E6.3	1/4	200	9	5
VK1/4-E6.3-250-FS	118219	E6.3	1/4	250	9	5
VK3/8-E6.3-50-FS	118214	E6.3	3/8	50	13	5
VK3/8-E6.3-75-FS	118215	E6.3	3/8	75	13	5
VK3/8-E6.3-102-FS	118216	E6.3	3/8	100	13	5
VK3/8-E6.3-125-FS	118225	E6.3	3/8	125	13	5
VK3/8-E6.3-152-FS	118217	E6.3	3/8	152	12,5	5
VK3/8-E6.3-200-FS	118220	E6.3	3/8	200	13,5	5
VK3/8-E6.3-250-FS	118221	E6.3	3/8	250	13,5	5
VK1/2-E6.3-50-FS	118222	E6.3	1/2	50	16,5	5
VK1/2-E6.3-75-FS	118224	E6.3	1/2	75	16,5	5



Antrieb SDS-plus® – Vierkant mit Federstift

Modell	Best.-Nr.	Antrieb	4kt Zoll	L mm	Ø mm	VE
VK1/4-SDS-75-FS	118330	SDS+	1/4	75	5	
VK3/8-SDS-60-FS	118331	SDS+	3/8	60	5	
VK1/2-SDS-65-FS	118332	SDS+	1/2	65	5	



Antrieb E 6,3 – Vierkant mit Federkugel

Modell	Best.-Nr.	Antrieb	4kt Zoll	L mm	Ø mm	VE
VK1/4-E6.3-KS-2	118250	E6.3	1/4	51	8,5	5
VK1/4-E6.3-KS-3	118253	E6.3	1/4	76	8,5	5
VK1/4-E6.3-KS-4	118256	E6.3	1/4	102	8,5	5
VK1/4-E6.3-KS-5	118258	E6.3	1/4	127	8,5	5
VK1/4-E6.3-KS-6	118264	E6.3	1/4	152	8,5	5
VK3/8-E6.3-KS-2	118251	E6.3	3/8	51	10	5
VK3/8-E6.3-KS-3	118254	E6.3	3/8	76	10	5
VK3/8-E6.3-KS-4	118257	E6.3	3/8	102	10	5
VK3/8-E6.3-KS-5	118259	E6.3	3/8	127	10	5
VK3/8-E6.3-KS-6	118265	E6.3	3/8	152	10	5
VK1/2-E6.3-KS-2	118252	E6.3	1/2	51	14,5	5
VK1/2-E6.3-KS-3	118255	E6.3	1/2	76	14,5	5



Antrieb E 6,3 – Vierkant mit Stiftloch

Modell	Best.-Nr.	Antrieb	4kt Zoll	L mm	Ø mm	VE
VK1/4-E6.3-50-SL	118260	E6.3	1/4	50	8,5	5
VK1/4-E6.3-75-SL	118261	E6.3	1/4	75	8,5	5
VK1/4-E6.3-200-SL	118262	E6.3	1/4	200	8	5
VK3/8-E6.3-75-SL	118263	E6.3	3/8	75	12,5	5



Antrieb E 11,2 – Vierkant mit Federstift

Modell	Best.-Nr.	Antrieb	4kt Zoll	L mm	Ø mm	VE
VK1/4-E11-50-FS	118310	E11	1/4	50	13	5
VK3/8-E11-75-FS	118311	E11	3/8	75	13	5
VK3/8-E11-125-FS	118312	E11	3/8	125	13	5
VK3/8-E11-200-FS	118313	E11	3/8	200	13	5
VK1/2-E11-70-FS	118314	E11	1/2	70	16	5
VK1/2-E11-75-FS	118317	E11	1/2	75	17	5
VK1/2-E11-125-FS	118315	E11	1/2	125	13	5
VK1/2-E11-200-FS	118316	E11	1/2	200	16,5	5

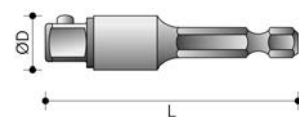
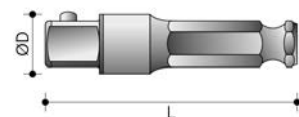

Bithalter – für Schraubendreher/Drehschrauber *



C6,3 Bithalter – Sprengring

Modell	Best.-Nr.	Antrieb	L mm	Ø mm	VE
BR6.3-E6.3-58	119010	E 6,3	58	11,2	5
BR6.3-G7-46	119013	G 7	46	11,2	5



C6,3 Schnellwechselhalter – Magnet – Sprengring

Modell	Best.-Nr.	Antrieb	L mm	Ø mm	VE
BRQM6.3-E6.3-51	119211	E 6,3	51	14,3	5
BRQM6.3-SDS-80	119214	SDS-plus®	80	14,3	5



Kombi-Schnellwechselhalter – Magnet – Sprengring

Modell	Best.-Nr.	Antrieb	L mm	Ø mm	VE
BRKM6.3-E6.3-60	119450	E 6,3	60	14,3	5
BRKM6.3-E6.3-75	119451	E 6,3	75	14,3	5
BRKM6.3-E6.3-150	119452	E 6,3	150	14,3	5



C6,3 Bithalter – Edelstahlhülse – Magnet – Sprengring

Modell	Best.-Nr.	Antrieb	L mm	Ø mm	VE
BRM6.3-E6.3-50	119112	E 6,3	51	10	5
BRM6.3-E6.3-60	119119	E 6,3	58	10	5
BRM6.3-E6.3-75	119110	E 6,3	75	10	5
BRM6.3-E6.3-100	119113	E 6,3	102	10	5
BRM6.3-E6.3-150	119114	E 6,3	152	10	5
BRM6.3-E6.3-200	119121	E 6,3	200	10	5
BRM6.3-E6.3-250	119122	E 6,3	250	10	5
BRM6.3-E6.3-300	119123	E 6,3	300	10	5
BRM6.3-G7-75	119115	G 7	75	10	5
BRM6.3-A5.5-70	119116	A 5,5	72	9,5	5
BRM6.3-SDS-75	119117	SDS-plus®	75	11	5



C6,3 Bithalter – CuBe-Hülse – Magnet – Sprengring

Modell	Best.-Nr.	Antrieb	L mm	Ø mm	VE
BRCU6.3-E6.3-74	119310	E 6,3	75	10,8	5

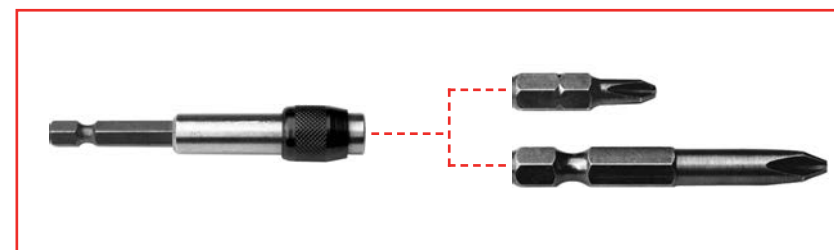

Vorzüge des Kombi-Bithalters

- Verwendbar mit beiden Bitantrieben Form C 6,3 und E 6,3.
- Durch Flexibilität bei der Aufnahme hat der Anwender stets den richtigen Halter zur Hand.
- Der Schnellwechselmechanismus gewährt eine feste und wackelfreie Verbindung zur Antriebsmaschine.
- Schneller Werkzeugwechsel spart Zeit und Geld.
- Hohe Qualität bürgt für langes Werkzeugleben.





Bits mit 1/4" Sechskantantrieb DIN 3126 / ISO 1173 – C 6,3 *



Schlitz – zähhart

Modell	Best.-Nr.	D mm	B mm	L mm	Ø mm	VE
SL0.5x3.0-C6.3-25	110010	0,5	3,0	25	3	10
SL0.5x4.0-C6.3-25	110014	0,5	4,0	25	4	10
SL0.6x3.5-C6.3-25	110012	0,6	3,5	25	3,5	10
SL0.6x4.0-C6.3-25	110028	0,6	4,0	25	4	10
SL0.6x4.5-C6.3-25	110016	0,6	4,5	25	4,5	10
SL0.8x4.0-C6.3-25	110029	0,8	4,0	25	4	10
SL0.8x5.5-C6.3-25	110018	0,8	5,5	25	5,5	10
SL1.0x5.5-C6.3-25	110020	1,0	5,5	25	5,5	10
SL1.2x6.5-C6.3-25	110030	1,0	6,0	25	6	10
SL1.2x6.5-C6.3-25	110022	1,2	6,5	25	6,5	10
SL1.2x8.0-C6.3-25	110024	1,2	8,0	25	8	10
SL1.6x8.0-C6.3-25	110031	1,6	8,0	25	8	10
SL1.6x10-C6.3-25	110026	1,6	10	25	10	10
SL2.0x12-C6.3-25	110032	2,0	12	25	12	10
SL0.5x3.0-C6.3-39	110011	0,5	3,0	39	3	10
SL0.5x4.0-C6.3-39	110015	0,5	4,0	39	4	10
SL0.6x3.5-C6.3-39	110013	0,6	3,5	39	3,5	10
SL0.6x4.0-C6.3-39	110033	0,6	4,0	39	4	10
SL0.6x4.5-C6.3-39	110017	0,6	4,5	39	4,5	10
SL0.8x5.5-C6.3-39	110019	0,8	5,5	39	5,5	10
SL1.0x5.5-C6.3-39	110021	1,0	5,5	39	5,5	10
SL1.0x6.0-C6.3-39	110034	1,0	6,0	39	6	10
SL1.2x6.5-C6.3-39	110023	1,2	6,5	39	6,5	10
SL1.2x8.0-C6.3-39	110025	1,2	8,0	39	8	10
SL1.6x8.0-C6.3-39	110035	1,6	8,0	39	8	10
SL1.6x10-C6.3-39	110027	1,6	10	39	10	10
SL2.0x12-C6.3-39	110036	2,0	12	39	12	10

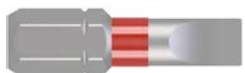

Schlitz – CR

Modell	Best.-Nr.	D mm	B mm	L mm	Ø mm	VE
SL0.6x3.5-C6.3-25-CR	110070	0,6	3,5	25	3,5	10
SL0.6x4.5-C6.3-25-CR	110071	0,6	4,5	25	4,5	10
SL1.0x5.5-C6.3-25-CR	110072	1,0	5,5	25	5,5	10
SL1.2x6.5-C6.3-25-CR	110073	1,2	6,5	25	6,5	10
SL1.6x8.0-C6.3-25-CR	110074	1,6	8,0	25	8	10



Schlitz – ZRN

Modell	Best.-Nr.	D mm	B mm	L mm	Ø mm	VE
SL0.6x4.5-C6.3-ZRN	110050	0,6	4,5	25	4,5	10
SL0.8x5.5-C6.3-ZRN	110051	0,8	5,5	25	5,5	10
SL1.0x6.5-C6.3-ZRN	110052	1,0	5,5	25	5,5	10
SL1.2x6.5-C6.3-ZRN	110053	1,2	6,5	25	6,5	10



Kreuzschlitz Phillips® – IMP

Modell	Best.-Nr.	PH #	L mm	Ø mm	VE
PH2-C6.3-25-IMP	111042	2	25	6	10
PH3-C6.3-25-IMP	111043	3	25	6,3	10



Kreuzschlitz Phillips® – zähhart

Modell	Best.-Nr.	PH #	L mm	Ø mm	VE
PH1-C6.3-18	111001	1	18	–	10
PH2-C6.3-18	111002	2	18	–	10
PH3-C6.3-18	111003	3	18	–	10
PH0-C6.3-25	111010	0	25	4	10
PH1-C6.3-25	111011	1	25	6,3	10
PH1-C6.3-25	111012	1	25	4,6	10
PH2-C6.3-25	111013	2	25	6,3	10
PH2-C6.3-25	111014	2	25	6,3	10
PH2-C6.3-25	111015	2	25	4,6	10
PH3-C6.3-25	111020	3	25	6,3	10
PH2-C6.3-32	111016	2	32	6,3	10
PH3-C6.3-32	111021	3	32	8,0	10
PH2-C6.3-38	111023	2	38	6,3	10
PH3-C6.3-38	111024	3	38	8	10
PH4-C6.3-38	111025	4	38	10	10
PH1-C6.3-50	111026	1	50	4,5	10
PH2-C6.3-50	111018	2	50	6,3	10
PH3-C6.3-50	111027	3	50	6,3	10
PH2-C6.3-64	111019	2	64	6,3	10



Bits mit 1/4" Sechskantantrieb DIN 3126 / ISO 1173 – C 6,3 *



Kreuzschlitz Phillips® – CR

Modell	Best.-Nr.	PH #	L mm	Ø mm	VE
PH1-C6.3-25-CR	111071	1	25	4,6	10
PH2-C6.3-25-CR	111072	2	25	6	10
PH3-C6.3-25-CR	111073	3	25	6,3	10



Kreuzschlitz Phillips® – ZRN

Modell	Best.-Nr.	PH #	L mm	Ø mm	VE
PH1-C6.3-25-ZRN	111051	1	25	4,6	10
PH2-C6.3-25-ZRN	111052	2	25	6	10
PH3-C6.3-25-ZRN	111053	3	25	6,3	10
PH1-C6.3-50-ZRN	111061	1	50	4,6	10
PH2-C6.3-50-ZRN	111062	2	50	6	10
PH3-C6.3-50-ZRN	111063	3	50	6,3	10



Kreuzschlitz Pozidriv® – IMP

Modell	Best.-Nr.	PZ #	L mm	Ø mm	VE
PZ2-C6.3-25-IMP	112042	2	25	6	10
PZ3-C6.3-25-IMP	112043	3	25	6,3	10



Kreuzschlitz Pozidriv® – zähhart

Modell	Best.-Nr.	PZ #	L mm	Ø mm	VE
PZ1-C6.3-18	112001	1	18	–	10
PZ2-C6.3-18	112002	2	18	–	10
PZ3-C6.3-18	112003	3	18	–	10
PZ0-C6.3-25	112009	0	25	4	10
PZ1-C6.3-25	112010	1	25	4,5	10
PZ2-C6.3-25	112012	2	25	6	10
PZ3-C6.3-25	112017	3	25	6,3	10
PZ2-C6.3-32	112013	2	32	6,3	10
PZ3-C6.3-32	112018	3	32	6,3	10
PZ4-C6.3-38	112019	4	38	10	10
PZ1-C6.3-50	112020	1	50	4,5	10
PZ2-C6.3-50	112015	2	50	6,3	10
PZ3-C6.3-50	112021	3	50	6,3	10



Kreuzschlitz Pozidriv® – CR

Modell	Best.-Nr.	PZ #	L mm	Ø mm	VE
PZ1-C6.3-25-CR	112071	1	25	4,6	10
PZ2-C6.3-25-CR	112072	2	25	6	10
PZ3-C6.3-25-CR	112073	3	25	6,3	10



Kreuzschlitz Pozidriv® – ZRN

Modell	Best.-Nr.	PZ #	L mm	Ø mm	VE
PZ1-C6.3-25-ZRN	112051	1	25	4,6	10
PZ2-C6.3-25-ZRN	112052	2	25	6	10
PZ3-C6.3-25-ZRN	112053	3	25	6,3	10
PZ1-C6.3-50-ZRN	112061	1	50	4,6	10
PZ2-C6.3-50-ZRN	112062	2	50	6	10
PZ3-C6.3-50-ZRN	112063	3	50	6,3	10

Ausführungen / Qualitätsstufen

- ZRN = mikrorauhe Oberfläche sorgt für bessere Haftung im Schraubenkopf und verminderte Auswurfkräfte – dadurch verbesserte Kraftübertragung, Abriebfestigkeit und Verschleiß.
- IMP = Impact Bits zeichnen sich dadurch aus, dass die permanente Schlägeinwirkung vom Werkzeug wesentlich besser aufgenommen wird – hohe Schlagresistenz, guter Korrosionsschutz, lange Lebensdauer.
- CR = Coloured Ring / Farbring.
- zähhart = ideal für Anwendungen, wo plötzliche Drehmomentanstiege zu erhöhten Beanspruchungen im Bit führen können. Ein harter Schraubfall liegt vor, wenn in Metall verschraubt wird.





Bits mit 1/4" Sechskantantrieb DIN 3126 / ISO 1173 – C 6,3 *



Sechsrund Torx® – zähhart

Modell	Best.-Nr.	TX #	L mm	Ø mm	VE
T10-C6.3-18	113001	10	18	4	10
T15-C6.3-18	113002	15	18	4	10
T20-C6.3-18	113003	20	18	5	10
T25-C6.3-18	113004	25	18	5	10
T30-C6.3-18	113005	30	18	6	10
T40-C6.3-18	113006	40	18	6,3	10
T5-C6.3-25	113010	5	25	3	10
T6-C6.3-25	113011	6	25	3	10
T7-C6.3-25	113012	7	25	3	10
T8-C6.3-25	113013	8	25	3	10
T9-C6.3-25	113014	9	25	3	10
T10-C6.3-25	113015	10	25	4	10
T15-C6.3-25	113016	15	25	4	10
T20-C6.3-25	113017	20	25	5	10
T25-C6.3-25	113018	25	25	5	10
T27-C6.3-25	113019	27	25	6	10
T30-C6.3-25	113020	30	25	6	10
T40-C6.3-25	113021	40	25	6,3	10
T45-C6.3-25	113022	45	25	8	10
T50-C6.3-25	113023	50	25	9	10
T9-C6.3-50	113030	9	50	3	10
T10-C6.3-50	113031	10	50	3	10
T15-C6.3-50	113032	15	50	4	10
T20-C6.3-50	113033	20	50	4,5	10
T25-C6.3-50	113034	25	50	6	10
T27-C6.3-50	113035	27	50	6	10
T30-C6.3-50	113036	30	50	6	10
T40-C6.3-50	113037	40	50	6,3	10



Sechsrund Torx® – IMP

Modell	Best.-Nr.	TX #	L mm	Ø mm	VE
T10-C6.3-25-IMP	113040	10	25	4	10
T15-C6.3-25-IMP	113041	15	25	4	10
T20-C6.3-25-IMP	113042	20	25	5	10
T25-C6.3-25-IMP	113043	25	25	5	10
T30-C6.3-25-IMP	113044	30	25	6	10
T40-C6.3-25-IMP	113045	40	25	6,3	10



Sechsrund Torx® – CR

Modell	Best.-Nr.	TX #	L mm	Ø mm	VE
T5-C6.3-25-CR	113070	5	25	3	10
T6-C6.3-25-CR	113071	6	25	3	10
T7-C6.3-25-CR	113072	7	25	3	10
T8-C6.3-25-CR	113073	8	25	3	10
T9-C6.3-25-CR	113074	9	25	3	10
T10-C6.3-25-CR	113075	10	25	4	10
T15-C6.3-25-CR	113076	15	25	4	10
T20-C6.3-25-CR	113077	20	25	5	10
T25-C6.3-25-CR	113078	25	25	5	10
T27-C6.3-25-CR	113079	27	25	6	10
T30-C6.3-25-CR	113080	30	25	6	10
T40-C6.3-25-CR	113081	40	25	6,3	10
T50-C6.3-25-CR	113082	50	25	9	10



Sechsrund Torx® – ZRN

Modell	Best.-Nr.	TX #	L mm	Ø mm	VE
T10-C6.3-25-ZRN	113050	10	25	4	10
T15-C6.3-25-ZRN	113051	15	25	4	10
T20-C6.3-25-ZRN	113052	20	25	5	10
T25-C6.3-25-ZRN	113053	25	25	5	10
T27-C6.3-25-ZRN	113054	27	25	6	10
T30-C6.3-25-ZRN	113055	30	25	6	10
T40-C6.3-25-ZRN	113056	40	25	6,3	10
T10-C6.3-50-ZRN	113060	10	50	3	10
T15-C6.3-50-ZRN	113061	15	50	4	10
T20-C6.3-50-ZRN	113062	20	50	4,5	10
T25-C6.3-50-ZRN	113063	25	50	6	10
T30-C6.3-50-ZRN	113064	30	50	6	10
T40-C6.3-50-ZRN	113065	40	50	6,3	10



Bits mit 1/4" Sechskantantrieb DIN 3126 / ISO 1173 – C 6,3 *



Sechsrund Torx® Kugelkopf – zähhart

Modell	Best.-Nr.	TK #	L mm	Ø mm	VE
TK10-C6.3-25	113410	10	25	–	10
TK15-C6.3-25	113411	15	25	–	10
TK20-C6.3-25	113412	20	25	–	10
TK25-C6.3-25	113413	25	25	–	10
TK27-C6.3-25	113414	27	25	–	10
TK30-C6.3-25	113415	30	25	–	10
TK40-C6.3-25	113416	40	25	–	10



Sechsrund Torx® Tamper-Resistant – zähhart

Modell	Best.-Nr.	TR #	L mm	Ø mm	VE
TR7-C6.3-25	114010	7	25	3	10
TR8-C6.3-25	114011	8	25	3	10
TR9-C6.3-25	114012	9	25	3	10
TR10-C6.3-25	114013	10	25	4	10
TR15-C6.3-25	114014	15	25	4	10
TR20-C6.3-25	114015	20	25	5	10
TR25-C6.3-25	114016	25	25	5	10
TR27-C6.3-25	114017	27	25	6	10
TR30-C6.3-25	114018	30	25	6	10
TR40-C6.3-25	114019	40	25	6,3	10
TR45-C6.3-35	114020	45	35	–	10



Sechsrund Torx® Tamper-Resistant – CR

Modell	Best.-Nr.	TR #	L mm	Ø mm	VE
TR7-C6.3-25-CR	114070	7	25	3	10
TR8-C6.3-25-CR	114071	8	25	3	10
TR9-C6.3-25-CR	114072	9	25	3	10
TR10-C6.3-25-CR	114073	10	25	4	10
TR15-C6.3-25-CR	114074	15	25	4	10
TR20-C6.3-25-CR	114075	20	25	5	10
TR25-C6.3-25-CR	114076	25	25	5	10
TR27-C6.3-25-CR	114077	27	25	6	10
TR30-C6.3-25-CR	114078	30	25	6	10
TR40-C6.3-25-CR	114079	40	25	6,3	10



Sechsrund Torx® Tamper-Resistant – ZRN

Modell	Best.-Nr.	TR #	L mm	Ø mm	VE
TR8-C6.3-25-ZRN	114050	8	25	3	10
TR10-C6.3-25-ZRN	114051	10	25	4	10
TR15-C6.3-25-ZRN	114052	15	25	4	10
TR20-C6.3-25-ZRN	114053	20	25	5	10
TR25-C6.3-25-ZRN	114054	25	25	5	10
TR27-C6.3-25-ZRN	114055	27	25	6	10
TR30-C6.3-25-ZRN	114056	30	25	6	10
TR40-C6.3-25-ZRN	114057	40	25	6,3	10



Sechsrund Torx Plus® IP – zähhart

Modell	Best.-Nr.	IP #	L mm	Ø mm	VE
IP5-C6.3-25	113710	5	25	–	10
IP6-C6.3-25	113711	6	25	–	10
IP7-C6.3-25	113712	7	25	–	10
IP8-C6.3-25	113713	8	25	–	10
IP9-C6.3-25	113714	9	25	–	10
IP10-C6.3-25	113715	10	25	–	10
IP15-C6.3-25	113716	15	25	–	10
IP20-C6.3-25	113717	20	25	–	10
IP25-C6.3-25	113718	25	25	–	10
IP27-C6.3-25	113719	27	25	–	10
IP30-C6.3-25	113720	30	25	–	10
IP40-C6.3-25	113721	40	25	–	10



Security Torx Plus® IPR – zähhart

Modell	Best.-Nr.	IPR #	L mm	Ø mm	VE
IPR10-C6.3-25	113610	10	25	–	10
IPR15-C6.3-25	113611	15	25	–	10
IPR20-C6.3-25	113612	20	25	–	10
IPR25-C6.3-25	113613	25	25	–	10
IPR27-C6.3-25	113616	27	25	–	10
IPR30-C6.3-25	113614	30	25	–	10
IPR40-C6.3-25	113615	40	25	–	10





Sechskant Inbus® – zähhart

Modell	Best.-Nr.	SW mm	L mm	Ø mm	VE
A4-C6.3-18	115001	4	18	–	10
A5-C6.3-18	115002	5	18	–	10
A6-C6.3-18	115003	6	18	–	10
A1-C6.3-25	115020	1	25	–	10
A1.5-C6.3-25	115010	1,5	25	–	10
A2-C6.3-25	115011	2	25	–	10
A2.5-C6.3-25	115012	2,5	25	–	10
A3-C6.3-25	115013	3	25	–	10
A4-C6.3-25	115014	4	25	–	10
A5-C6.3-25	115015	5	25	–	10
A5.5-C6.3-25	115021	5,5	25	–	10
A6-C6.3-25	115016	6	25	–	10
A7-C6.3-25	115019	7	25	–	10
A8-C6.3-25	115017	8	25	–	10
A10-C6.3-25	115018	10	25	–	10



Sechskant Inbus® – zähhart – Zoll

Modell	Best.-Nr.	SW Zoll	L mm	Ø mm	VE
A1/16-C6.3-25	115030	1/16	25	–	10
A5/64-C6.3-25	115031	5/64	25	–	10
A3/32-C6.3-25	115032	3/32	25	–	10
A7/64-C6.3-25	115033	7/64	25	–	10
A1/8-C6.3-25	115034	1/8	25	–	10
A9/64-C6.3-25	115035	9/64	25	–	10
A5/32-C6.3-25	115036	5/32	25	–	10
A3/16-C6.3-25	115037	3/16	25	–	10
A7/32-C6.3-25	115038	7/32	25	–	10
A1/4-C6.3-25	115039	1/4	25	–	10



Sechskant Inbus® – CR

Modell	Best.-Nr.	SW mm	L mm	Ø mm	VE
A2-C6.3-25-CR	115070	2	25	–	10
A2.5-C6.3-25-CR	115071	2,5	25	–	10
A3-C6.3-25-CR	115072	3	25	–	10
A4-C6.3-25-CR	115073	4	25	–	10
A5-C6.3-25-CR	115074	5	25	–	10
A6-C6.3-25-CR	115075	6	25	–	10



Sechskant Inbus® – ZRN

Modell	Best.-Nr.	SW mm	L mm	Ø mm	VE
A2-C6.3-25-ZRN	115050	2	25	–	10
A3-C6.3-25-ZRN	115051	3	25	–	10
A4-C6.3-25-ZRN	115052	4	25	–	10
A5-C6.3-25-ZRN	115053	5	25	–	10
A6-C6.3-25-ZRN	115054	6	25	–	10



Sechskant Inbus® Kugelkopf – zähhart

Modell	Best.-Nr.	SW mm	L mm	Ø mm	VE
AK2.5-C6.3-25	115410	2,5	25	–	10
AK3-C6.3-25	115411	3	25	–	10
AK4-C6.3-25	115412	4	25	–	10
AK5-C6.3-25	115413	5	25	–	10
AK6-C6.3-25	115414	6	25	–	10



Vielzahn XZN – zähhart

Modell	Best.-Nr.	SW #	L mm	Ø mm	VE
XZN4-C6.3-25	116010	4	25	4	10
XZN5-C6.3-25	116011	5	25	5	10
XZN6-C6.3-25	116012	6	25	6	10
XZN8-C6.3-25	116013	8	25	8	10
XZN10-C6.3-25	116014	10	25	10	10



Innenvierkant – zähhart

Modell	Best.-Nr.	SW #	L mm	Ø mm	VE
SQ0-C6.3-25	116510	0	25	–	10
SQ1-C6.3-25	116511	1	25	–	10
SQ2-C6.3-25	116512	2	25	–	10
SQ3-C6.3-25	116513	3	25	–	10
SQ4-C6.3-25	116514	4	25	–	10



Innenvierkant – CR

Modell	Best.-Nr.	SW #	L mm	Ø mm	VE
SQ0-C6.3-25-CR	116570	0	25	–	10
SQ1-C6.3-25-CR	116571	1	25	–	10
SQ2-C6.3-25-CR	116572	2	25	–	10
SQ3-C6.3-25-CR	116573	3	25	–	10



Torq-Set® – zähhart

Modell	Best.-Nr.	SW #	L mm	Ø mm	VE
TS0-C6.3-25	116600	0	25	–	10
TS1-C6.3-25	116601	1	25	–	10
TS2-C6.3-25	116602	2	25	–	10
TS3-C6.3-25	116603	3	25	–	10
TS4-C6.3-25	116604	4	25	–	10
TS5-C6.3-25	116605	5	25	–	10
TS6-C6.3-25	116610	6	25	–	10
TS8-C6.3-25	116611	8	25	–	10
TS10-C6.3-25	116612	10	25	–	10
TS1/4-C6.3-25	116613	1/4	25	–	10



Tri-Wing® – zähhart

Modell	Best.-Nr.	SW #	L mm	Ø mm	VE
TW0-C6.3-25	116410	0	25	–	10
TW1-C6.3-25	116411	1	25	–	10
TW2-C6.3-25	116412	2	25	–	10
TW3-C6.3-25	116413	3	25	–	10
TW4-C6.3-25	116414	4	25	–	10
TW5-C6.3-25	116415	5	25	–	10
TW6-C6.3-32	116416	6	32	–	10
TW7-C6.3-32	116417	7	32	–	10
TW8-C6.3-32	116418	8	32	–	10



Spanner

Modell	Best.-Nr.	Größe #	L mm	Ø mm	VE
SP4-C6.3-25	116710	4	25	4,5	10
SP6-C6.3-25	116712	6	25	5,5	10
SP8-C6.3-25	116713	8	25	5,5	10
SP10-C6.3-25	116714	10	25	6,5	10



Bits mit 1/4" Sechskantantrieb DIN 3126 / ISO 1173 – C 6,3



Einschnitt-Gewindebohrer ISO/DIN 13

Modell	Best.-Nr.	Nennmaß	L2 mm	L1 mm	Ø mm	VE
M3-C6.3-33	793130	M 3 x 0,5	11	33	-	10
M4-C6.3-35	793131	M 4 x 0,7	12	35	-	10
M5-C6.3-36	793132	M 5 x 0,8	15	36	-	10
M6-C6.3-39	793133	M 6 x 1,0	18	39	-	10
M8-C6.3-40	793134	M 8 x 1,25	19	40	-	10
M10-C6.3-41	793135	M 10 x 1,5	21	41	-	10

Kernloch-Spiralbohrer HSS-G

Modell	Best.-Nr.	Nennmaß	L2 mm	L1 mm	Ø mm	VE
KSB2.5-C6.3-36	793137	M 3	14	36	2,5	10
KSB3.3-C6.3-40	793138	M 4	18	40	3,3	10
KSB4.2-C6.3-45	793139	M 5	20	45	4,2	10
KSB5.0-C6.3-50	793140	M 6	26	50	5,0	10
KSB6.8-C6.3-50	793141	M 8	30	50	6,8	10
KSB8.5-C6.3-53	793142	M 10	33	53	8,5	10



Gewinde-/Spiralbohrer im Satz

Modell	Best.-Nr.	Satz	Inhalt	VE
GSS-6	793136	6-teilig	Gewindebohrer M3-M10	1
GSS-12	793127	12-teilig	Gewinde-/Kernlochbohrer M3-M10	1
GSS-19	793128	19-teilig	Kernlochbohrer 1-10 mm	1



Einschnittgewindebohrer-Bits für metrische ISO-Gewinde DIN 13

Diese Bits sind für das Gewindereinigen mit (Akku-)Drehschraubern mit Schnellwechselfutter konzipiert. Ideal einsetzbar bei z.B. durch Lack verunreinigten Gewinden.

Der Sechskantantrieb nach DIN 3126 / ISO 1173 ermöglicht schnellsten Werkzeugwechsel: Werkende reinigen die Gewindebohrung, wechseln rasch den Bit und verschrauben mit dem gewünschten Drehmoment – fertig.

Für das Gewindereinigen mit Akkuschaubern empfehlen wir die folgenden Einstellungen:

- Min. Drehzahl (0-450 rpm)
- Max. Drehmoment

Einschnittgewindebohrer-Bits sind jeweils als 10er Pack erhältlich. Universell gerüstet ist man mit dem 6-teiligen Satz (793136) in Kunststoffkassette mit je einem Einschnittgewindebohrer-Bit pro Größe. Alle genannten Varianten sind kurzfristig lieferbar.

Bits mit 5/16" Sechskantantrieb DIN 3126 / ISO 1173 – C 8 *

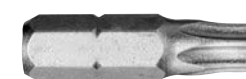

Schlitz – zähhart

Modell	Best.-Nr.	D mm	B mm	L mm	Ø mm	VE
SL0.6x1.0-C8-41	110109	0,6	4,0	41	4	10
SL0.6x4.5-C8-41	110110	0,6	4,5	41	4,5	10
SL0.8x4.0-C8-41	110120	0,8	4,0	41	4	10
SL0.8x5.5-C8-41	110111	0,8	5,5	41	5,5	10
SL1.0x5.5-C8-41	110112	1,0	5,5	41	5,5	10
SL1.0x6.0-C8-41	110121	1,0	6,0	41	6	10
SL1.2x6.5-C8-41	110113	1,2	6,5	41	6,5	10
SL1.2x8.0-C8-41	110114	1,2	8,0	41	8	10
SL1.6x8.0-C8-41	110115	1,6	8,0	41	8	10
SL1.6x10-C8-41	110116	1,6	10	41	10	10
SL2.0x12-C8-41	110117	2,0	12	41	12	10
SL2.0x14-C8-41	110118	2,0	14	41	14	10
SL2.5x16-C8-41	110119	2,5	16	41	16	10

Sechsrund Torx® – zähhart

Modell	Best.-Nr.	TX #	L mm	Ø mm	VE
T15-C8-35	113108	15	35	4	10
T20-C8-35	113109	20	35	4,5	10
T25-C8-35	113110	25	35	6	10
T27-C8-35	113111	27	35	6	10
T30-C8-35	113112	30	35	6	10
T40-C8-35	113113	40	35	7	10
T45-C8-35	113114	45	35	8	10
T50-C8-35	113115	50	35	8	10
T55-C8-35	113116	55	35	12	10



Sechskant Inbus® – zähhart

Modell	Best.-Nr.	SW mm	L mm	Ø mm	VE
A2.5-C8-30	115109	2,5	30	3,5	10
A3-C8-30	115110	3	30	4	10
A4-C8-30	115111	4	30	5	10
A5-C8-30	115112	5	30	6	10
A6-C8-30	115113	6	30	-	10
A7-C8-30	115116	7	30	-	10
A8-C8-30	115114	8	30	10	10
A10-C8-30	115115	10	30	12	10



Kreuzschlitz Phillips® – zähhart

Modell	Best.-Nr.	PH #	L mm	Ø mm	VE
PH1-C8-32	111110	1	32	4,5	10
PH2-C8-32	111111	2	32	6	10
PH3-C8-32	111112	3	32	7,9	10
PH4-C8-32	111113	4	32	7,9	10



Kreuzschlitz Pozidriv® – zähhart

Modell	Best.-Nr.	PZ #	L mm	Ø mm	VE
PZ1-C8-32	112110	1	32	4,5	10
PZ2-C8-32	112111	2	32	6	10
PZ3-C8-32	112112	3	32	7,9	10
PZ4-C8-32	112113	4	32	7,9	10



Vielzahn XZN – zähhart

Modell	Best.-Nr.	XZN #	L mm	Ø mm	VE
XZN5-C8	116111	M5	28	5	10
XZN6-C8	116112	M6	28	6	10
XZN8-C8	116113	M8	28	8	10
XZN10-C8	116114	M10	38	10	10
XZN12-C8	116115	M12	38	12	10
XZN14-C8	116116	M14	38	14	10





Bits mit 1/4" Sechskantantrieb DIN 3126 / ISO 1173 – E 6,3 *



— Schlitz – zähhart

Modell	Best.-Nr.	D mm	B mm	L mm	Ø mm	VE
SL0.5x3.0-E6.3-50	110210	0,5	3,0	50	3	10
SL0.5x4.0-E6.3-50	110222	0,5	4,0	50	4	10
SL0.6x3.5-E6.3-50	110216	0,6	3,5	50	3,5	10
SL0.6x4.0-E6.3-50	110258	0,6	4,0	50	4	10
SL0.6x4.5-E6.3-50	110228	0,6	4,5	50	4,5	10
SL0.8x4.0-E6.3-50	110259	0,8	4,0	50	4	10
SL0.8x5.5-E6.3-50	110234	0,8	5,5	50	5,5	10
SL1.0x5.5-E6.3-50	110240	1,0	5,5	50	5,5	10
SL1.0x6.0-E6.3-50	110260	1,0	6,0	50	6	10
SL1.2x6.5-E6.3-50	110246	1,2	6,5	50	6,5	10
SL1.2x8.0-E6.3-50	110252	1,2	8,0	50	8	10
SL1.6x10-E6.3-50	110261	1,6	10	50	10	10
SL0.5x3.0-E6.3-70	110211	0,5	3,0	70	3	10
SL0.5x4.0-E6.3-70	110223	0,5	4,0	70	4	10
SL0.6x3.5-E6.3-70	110217	0,6	3,5	70	3,5	10
SL0.6x4.5-E6.3-70	110229	0,6	4,5	70	4,5	10
SL0.8x4.0-E6.3-70	110262	0,8	4,0	70	4	10
SL0.8x5.5-E6.3-70	110235	0,8	5,5	70	5,5	10
SL1.0x5.5-E6.3-70	110241	1,0	5,5	70	5,5	10
SL1.0x6.0-E6.3-70	110263	1,0	6,0	70	6	10
SL1.2x6.5-E6.3-70	110247	1,2	6,5	70	6,5	10
SL1.2x8.0-E6.3-70	110253	1,2	8,0	70	8	10
SL0.5x3.0-E6.3-90	110212	0,5	3,0	90	3	10
SL0.5x4.0-E6.3-90	110224	0,5	4,0	90	4	10
SL0.6x3.5-E6.3-90	110218	0,6	3,5	90	3,5	10
SL0.6x4.5-E6.3-90	110230	0,6	4,5	90	4,5	10
SL0.8x5.5-E6.3-90	110236	0,8	5,5	90	5,5	10
SL1.0x5.5-E6.3-90	110242	1,0	5,5	90	5,5	10
SL1.2x6.5-E6.3-90	110248	1,2	6,5	90	6,5	10
SL1.2x8.0-E6.3-90	110254	1,2	8,0	90	8	10



+ Kreuzschlitz Phillips® – IMP

Modell	Best.-Nr.	PH #	L mm	Ø mm	VE
PH2-E6.3-50-IMP	111282	2	50	6	10
PH3-E6.3-50-IMP	111283	3	50	6	10

+ Kreuzschlitz Phillips® – zähhart

Modell	Best.-Nr.	PH #	L mm	Ø mm	VE
PH0-E6.3-50	111209	0	50	4	10
PH1-E6.3-50	111210	1	50	4,5	10
PH2-E6.3-50	111216	2	50	6	10
PH3-E6.3-50	111222	3	50	6	10
PH4-E6.3-50	111228	4	50	6	10
PH0-E6.3-70	111234	0	70	4	10
PH1-E6.3-70	111211	1	70	4,5	10
PH2-E6.3-70	111217	2	70	6,0	10
PH3-E6.3-70	111223	3	70	6,3	10
PH1-E6.3-90	111212	1	90	4,5	10
PH2-E6.3-90	111218	2	90	6	10
PH3-E6.3-90	111224	3	90	6	10
PH1-E6.3-102	111213	1	102	4,5	10
PH2-E6.3-102	111219	2	102	6,0	10
PH3-E6.3-102	111225	3	102	6,3	10
PH1-E6.3-110	111235	1	110	4,5	10
PH2-E6.3-110	111237	2	110	6	10
PH3-E6.3-110	111239	3	110	6	10
PH1-E6.3-127	111214	1	127	4,5	10
PH2-E6.3-127	111220	2	127	6,0	10
PH3-E6.3-127	111226	3	127	6,3	10
PH1-E6.3-152	111215	1	152	4,5	10
PH2-E6.3-152	111221	2	152	6	10
PH3-E6.3-152	111227	3	152	6	10
PH2-E6.3-170	111236	2	170	6	10
PH2-E6.3-200	111238	2	200	6	10
PH2-E6.3-270	111240	2	270	8	10
PH2-E6.3-300	111241	2	300	8	10



+ Kreuzschlitz Phillips® – ZRN

Modell	Best.-Nr.	PH #	L mm	Ø mm	VE
PH1-E6.3-50-ZRN	111451	1	50	4,5	10
PH2-E6.3-50-ZRN	111454	2	50	6	10
PH3-E6.3-50-ZRN	111457	3	50	6	10
PH1-E6.3-70-ZRN	111452	1	70	4,5	10
PH2-E6.3-70-ZRN	111455	2	70	6	10
PH3-E6.3-70-ZRN	111458	3	70	6	10
PH1-E6.3-90-ZRN	111453	1	90	4,5	10
PH2-E6.3-90-ZRN	111456	2	90	6	10
PH3-E6.3-90-ZRN	111459	3	90	6	10



Bits mit 1/4" Sechskantantrieb DIN 3126 / ISO 1173 – E 6,3 *



+ Kreuzschlitz Pozidriv® – zähhart

Modell	Best.-Nr.	PZ #	L mm	Ø mm	VE
PZ0-E6.3-50	112201	0	50	4	10
PZ1-E6.3-50	112210	1	50	4,5	10
PZ2-E6.3-50	112216	2	50	6	10
PZ3-E6.3-50	112222	3	50	6	10
PZ4-E6.3-50	112228	4	50	10	10
PZ0-E6.3-70	112202	0	70	4	10
PZ1-E6.3-70	112211	1	70	4,5	10
PZ2-E6.3-70	112217	2	70	6	10
PZ3-E6.3-70	112223	3	70	6,3	10
PZ1-E6.3-90	112212	1	90	4,5	10
PZ2-E6.3-90	112218	2	90	6	10
PZ3-E6.3-90	112224	3	90	6,3	10
PZ1-E6.3-102	112229	1	102	4,5	10
PZ2-E6.3-102	112232	2	102	6	10
PZ3-E6.3-102	112235	3	102	6	10
PZ1-E6.3-110	112230	1	110	4,5	10
PZ2-E6.3-110	112233	2	110	6	10
PZ3-E6.3-110	112236	3	110	6	10
PZ1-E6.3-127	112231	1	127	4,5	10
PZ2-E6.3-127	112234	2	127	6	10
PZ3-E6.3-127	112237	3	127	6	10
PZ1-E6.3-152	112215	1	152	4,5	10
PZ2-E6.3-152	112221	2	152	6	10
PZ3-E6.3-152	112227	3	152	6	10



+ Kreuzschlitz Pozidriv® – ZRN

Modell	Best.-Nr.	PH #	L mm	Ø mm	VE
PZ1-E6.3-50-ZRN	112251	1	50	4,5	10
PZ2-E6.3-50-ZRN	112254	2	50	6	10
PZ3-E6.3-50-ZRN	112257	3	50	6	10
PZ1-E6.3-70-ZRN	112252	1	70	4,5	10
PZ2-E6.3-70-ZRN	112255	2	70	6	10
PZ3-E6.3-70-ZRN	112258	3	70	6	10
PZ1-E6.3-90-ZRN	112253	1	90	4,5	10
PZ2-E6.3-90-ZRN	112256	2	90	6	10
PZ3-E6.3-90-ZRN	112259	3	90	6	10

+ Kreuzschlitz Pozidriv® – IMP

Modell	Best.-Nr.	PH #	L mm	Ø mm	VE
PZ2-E6.3-50-IMP	112242	2	50	6	10
PZ3-E6.3-50-IMP	112243	3	50	6	10



+ Sechsrund Torx® – zähhart

Modell	Best.-Nr.	TX #	L mm	Ø mm	VE
T6-E6.3-50	113210	6	50	3	10
T7-E6.3-50	113260	7	50	3	10
T8-E6.3-50	113213	8	50	3	10
T9-E6.3-50	113265	9	50	3	10
T10-E6.3-50	113216	10	50	3	10
T15-E6.3-50	113222	15	50	4	10
T20-E6.3-50	113228	20	50	4,5	10
T25-E6.3-50	113234	25	50	6	10
T27-E6.3-50	113240	27	50	6	10
T30-E6.3-50	113246	30	50	6	10
T40-E6.3-50	113252	40	50	6,3	10
T50-E6.3-50	113270	50	50	8	10
T55-E6.3-50	113271	55	50	10	10
T6-E6.3-70	113211	6	70	3	10
T7-E6.3-70	113261	7	70	3	10
T8-E6.3-70	113214	8	70	3	10
T9-E6.3-70	113266	9	70	3	10
T10-E6.3-70	113217	10	70	3	10
T15-E6.3-70	113223	15	70	4	10
T20-E6.3-70	113229	20	70	4,5	10
T25-E6.3-70	113235	25	70	6	10
T27-E6.3-70	113241	27	70	6	10
T30-E6.3-70	113247	30	70	6	10
T40-E6.3-70	113253	40	70	6,3	10
T6-E6.3-90	113258	6	90	3	10
T7-E6.3-90	113262	7	90	3	10
T8-E6.3-90	113215	8	90	3	10
T9-E6.3-90	113267	9	90	3	10
T10-E6.3-90	113218	10	90	3	10
T15-E6.3-90	113224	15	90	4	10
T20-E6.3-90	113230	20	90	4,5	10
T25-E6.3-90	113236	25	90	6	10
T27-E6.3-90	113242	27	90	6	10
T30-E6.3-90	113248	30	90	6,0	10





Bits mit 1/4" Sechskantantrieb DIN 3126 / ISO 1173 – E 6,3 *

Sechsrund Torx® – zähhart

Modell	Best.-Nr.	TX #	L mm	Ø mm	VE
T40-E6.3-90	113254	40	90	6,3	10
T15-E6.3-102	113225	15	102	4,0	10
T20-E6.3-102	113231	20	102	4,5	10
T25-E6.3-102	113237	25	102	6,0	10
T30-E6.3-102	113249	30	102	6,0	10
T40-E6.3-102	113255	40	102	6,3	10
T10-E6.3-127	113220	10	127	3,0	10
T15-E6.3-127	113226	15	127	4,0	10
T20-E6.3-127	113232	20	127	4,5	10
T25-E6.3-127	113238	25	127	6,0	10
T27-E6.3-127	113244	27	127	6,0	10
T30-E6.3-127	113250	30	127	6,0	10
T40-E6.3-127	113256	40	127	6,3	10
T6-E6.3-152	113259	6	152	3	10
T7-E6.3-152	113263	7	152	3	10
T8-E6.3-152	113264	8	152	3	10
T9-E6.3-152	113268	9	152	3	10
T10-E6.3-152	113221	10	152	3	10
T15-E6.3-152	113227	15	152	4	10
T20-E6.3-152	113233	20	152	4,5	10
T25-E6.3-152	113239	25	152	6	10
T27-E6.3-152	113245	27	152	6	10
T30-E6.3-152	113251	30	152	6	10
T40-E6.3-152	113257	40	152	6,3	10
T45-E6.3-152	113269	45	152	7	10
T20-E6.3-200	113272	20	200	4,5	10
T25-E6.3-200	113273	25	200	6	10
T30-E6.3-200	113276	30	200	6	10
T25-E6.3-250	113274	25	250	6	10
T30-E6.3-250	113277	30	250	6	10
T25-E6.3-300	113275	25	300	6	10
T30-E6.3-325	113278	30	325	6	10
T30-E6.3-400	113279	25	400	6	10



Sechsrund Torx® – ZRN

Modell	Best.-Nr.	TX #	L mm	Ø mm	VE
T8-E6.3-50-ZRN	113291	8	50	3	10
T10-E6.3-50-ZRN	113292	10	50	3	10
T15-E6.3-50-ZRN	113293	15	50	4	10
T20-E6.3-50-ZRN	113294	20	50	4,5	10
T25-E6.3-50-ZRN	113295	25	50	6	10
T30-E6.3-50-ZRN	113296	30	50	6	10
T40-E6.3-50-ZRN	113297	40	50	–	10



Sechsrund Torx® – IMP

Modell	Best.-Nr.	TX #	L mm	Ø mm	VE
T10-E6.3-50-IMP	113281	10	50	3	10
T15-E6.3-50-IMP	113282	15	50	4	10
T20-E6.3-50-IMP	113283	20	50	4,5	10
T25-E6.3-50-IMP	113284	25	50	6	10
T30-E6.3-50-IMP	113285	30	50	6	10
T40-E6.3-50-IMP	113286	40	50	–	10



Sechsrund Torx Plus® IP – zähhart

Modell	Best.-Nr.	IP #	L mm	Ø mm	VE
IP6-E6.3-50	113601	6	50	3	10
IP8-E6.3-50	113603	8	50	3	10
IP9-E6.3-50	113605	9	50	3	10
IP10-E6.3-50	113607	10	50	3	10
IP15-E6.3-50	113609	15	50	4	10
IP20-E6.3-50	113611	20	50	4,5	10
IP25-E6.3-50	113613	25	50	6	10
IP30-E6.3-50	113615	30	50	6	10
IP40-E6.3-50	113617	40	50	–	10
IP6-E6.3-90	113602	6	90	3	10
IP8-E6.3-90	113604	8	90	3	10
IP9-E6.3-90	113606	9	90	3	10
IP10-E6.3-90	113608	10	90	3	10
IP15-E6.3-90	113610	15	90	4	10
IP20-E6.3-90	113612	20	90	4,5	10
IP25-E6.3-90	113614	25	90	6	10
IP30-E6.3-90	113616	30	90	6	10
IP40-E6.3-90	113618	40	90	–	10



Bits mit 1/4" Sechskantantrieb DIN 3126 / ISO 1173 – E 6,3 *

Sechsrund Torx® Tamper-Resistant – zähhart

Modell	Best.-Nr.	TR #	L mm	Ø mm	VE
TR8-E6.3-50	114208	8	50	3	10
TR9-E6.3-50	114211	9	50	3	10
TR10-E6.3-50	114214	10	50	3	10
TR15-E6.3-50	114218	15	50	4	10
TR20-E6.3-50	114222	20	50	4,5	10
TR25-E6.3-50	114226	25	50	6	10
TR27-E6.3-50	114230	27	50	6	10
TR30-E6.3-50	114233	30	50	6	10
TR40-E6.3-50	114237	40	50	–	10
TR8-E6.3-70	114209	8	70	3	10
TR9-E6.3-70	114212	9	70	3	10
TR10-E6.3-70	114215	10	70	3	10
TR15-E6.3-70	114219	15	70	4	10
TR20-E6.3-70	114223	20	70	4,5	10
TR25-E6.3-70	114227	25	70	6	10
TR27-E6.3-70	114231	27	70	6	10
TR30-E6.3-70	114234	30	70	6	10
TR40-E6.3-70	114238	40	70	6,3	10
TR8-E6.3-90	114210	8	90	3	10
TR9-E6.3-90	114213	9	90	3	10
TR10-E6.3-90	114216	10	90	3	10
TR15-E6.3-90	114220	15	90	4	10
TR20-E6.3-90	114224	20	90	4,5	10
TR25-E6.3-90	114228	25	90	6	10
TR27-E6.3-90	114232	27	90	6	10
TR30-E6.3-90	114235	30	90	6,0	10
TR40-E6.3-90	114239	40	90	6,3	10
TR10-E6.3-152	114217	10	152	3	10
TR15-E6.3-152	114221	15	152	4	10
TR20-E6.3-152	114225	20	152	4,5	10
TR25-E6.3-152	114229	25	152	6	10
TR30-E6.3-152	114236	30	152	6	10



Sechskant Inbus® – zähhart

Modell	Best.-Nr.	SW mm	L mm	Ø mm	VE
A1-E6.3-50	115201	1	50	3	10
A1.5-E6.3-50	115202	1,5	50	3	10
A2-E6.3-50	115204	2	50	3	10
A2.5-E6.3-50	115210	2,5	50	3,5	10
A3-E6.3-50	115212	3	50	4	10
A4-E6.3-50	115214	4	50	5	10
A5-E6.3-50	115216	5	50	6	10
A5.5-E6.3-50	115231	5,5	50	6	10
A6-E6.3-50	115218	6	50	7	10
A7-E6.3-50	115235	7	50	8	10
A8-E6.3-50	115220	8	50	10	10
A10-E6.3-50	115222	10	50	12	10
A1.5-E6.3-70	115203	1,5	70	3	10
A2-E6.3-70	115205	2	70	3	10
A2.5-E6.3-70	115211	2,5	70	3,5	10
A3-E6.3-70	115213	3	70	4	10
A4-E6.3-70	115215	4	70	5	10
A5-E6.3-70	115217	5	70	6	10
A6-E6.3-70	115219	6	70	7	10
A8-E6.3-70	115221	8	70	10	10
A2-E6.3-90	115206	2	90	3	10
A2.5-E6.3-90	115223	2,5	90	3,5	10
A3-E6.3-90	115225	3	90	4	10
A4-E6.3-90	115227	4	90	5	10
A5-E6.3-90	115229	5	90	6	10
A6-E6.3-90	115233	6	90	7	10
A7-E6.3-90	115236	7	90	8	10
A8-E6.3-90	115237	8	90	10	10
A2-E6.3-152	115207	2	152	3	10
A2.5-E6.3-152	115224	2,5	152	3,5	10
A3-E6.3-152	115226	3	152	4	10
A4-E6.3-152	115228	4	152	5	10
A5-E6.3-152	115230	5	152	6	10
A5.5-E6.3-152	115232	5,5	152	6	10
A6-E6.3-152	115234	6	152	7	10
A8-E6.3-152	115238	8	152	10	10

* In Verbindung mit Kombi-Bithalter oder für direkten Maschinenanschluss, vgl. Tabelle „Zuordnung von Werkzeugantrieb und Maschine“.

Weitere Infos auf unserer Website.



Weitere Infos auf unserer Website.

* In Verbindung mit Kombi-Bithalter oder für direkten Maschinenanschluss, vgl. Tabelle „Zuordnung von Werkzeugantrieb und Maschine“.

Bits mit 1/4" Sechskantantrieb DIN 3126 / ISO 1173 – E 6,3 *



Sechskant Inbus® Kugelkopf – zähhart

Modell	Best.-Nr.	SW mm	L mm	Ø mm	VE
AK2-E6.3-50	115520	2	50	3	10
AK2.5-E6.3-50	115521	2,5	50	3,5	10
AK3-E6.3-50	115522	3	50	4	10
AK4-E6.3-50	115523	4	50	5	10
AK5-E6.3-50	115524	5	50	6	10
AK6-E6.3-50	115525	6	50	7	10
AK7-E6.3-50	115526	7	50	8	10
AK8-E6.3-50	115527	8	50	10	10
AK2-E6.3-70	115530	2	70	3	10
AK2.5-E6.3-70	115531	2,5	70	3,5	10
AK3-E6.3-70	115532	3	70	4	10
AK4-E6.3-70	115533	4	70	5	10
AK5-E6.3-70	115534	5	70	6	10
AK6-E6.3-70	115535	6	70	7	10
AK7-E6.3-70	115536	7	70	8	10
AK8-E6.3-70	115537	8	70	10	10
AK2-E6.3-76	115510	2	76.2	–	10
AK2.5-E6.3-76	115511	2,5	76.2	–	10
AK3-E6.3-76	115512	3	76.2	–	10
AK4-E6.3-76	115513	4	76.2	–	10
AK5-E6.3-76	115514	5	76.2	–	10
AK6-E6.3-76	115515	6	76.2	–	10
AK8-E6.3-76	115516	8	76.2	–	10
AK10-E6.3-76	115517	10	76.2	–	10
AK12-E6.3-76	115518	12	76.2	–	10
AK2-E6.3-90	115540	2	90	3	10
AK2.5-E6.3-90	115541	2,5	90	3,5	10
AK3-E6.3-90	115542	3	90	4	10
AK4-E6.3-90	115543	4	90	5	10
AK5-E6.3-90	115544	5	90	6	10
AK6-E6.3-90	115545	6	90	7	10
AK7-E6.3-90	115546	7	90	8	10
AK8-E6.3-90	115547	8	90	10	10
AK2-E6.3-152	115550	2	152	3	10
AK2.5-E6.3-152	115551	2,5	152	3,5	10
AK3-E6.3-152	115552	3	152	4	10
AK4-E6.3-152	115553	4	152	5	10
AK5-E6.3-152	115554	5	152	6	10
AK6-E6.3-152	115555	6	152	7	10
AK8-E6.3-152	115556	8	152	10	10

Sechskant Inbus® – zähhart – Zoll

Modell	Best.-Nr.	SW Zoll	L mm	Ø mm	VE
A1/16-E6.3-50	115250	1/16	50	3	10
A5/64-E6.3-50	115251	5/64	50	3	10
A3/32-E6.3-50	115252	3/32	50	3,5	10
A7/64-E6.3-50	115253	7/64	50	4	10
A1/8-E6.3-50	115254	1/8	50	4	10
A9/64-E6.3-50	115255	9/64	50	–	10
A5/32-E6.3-50	115256	5/32	50	5	10
A3/16-E6.3-50	115257	3/16	50	6	10
A7/32-E6.3-50	115258	7/32	50	–	10
A1/4-E6.3-50	115259	1/4	50	6,3	10



Sechskant Inbus® – ZRN

Modell	Best.-Nr.	SW mm	L mm	Ø mm	VE
A2-E6.3-50-ZRN	115260	2	50	3	10
A3-E6.3-50-ZRN	115261	3	50	4	10
A4-E6.3-50-ZRN	115262	4	50	5	10
A5-E6.3-50-ZRN	115263	5	50	6	10
A6-E6.3-50-ZRN	115264	6	50	7	10



Vielzahn XZN – zähhart

Modell	Best.-Nr.	XZN #	L mm	Ø mm	VE
XZN4-E6.3-50	116210	M4	50	4	10
XZN5-E6.3-50	116211	M5	50	5	10
XZN6-E6.3-50	116212	M6	50	6	10
XZN8-E6.3-50	116213	M8	50	8	10
XZN10-E6.3-50	116214	M10	50	10	10
XZN12-E6.3-50	116215	M12	50	12	10

Bits mit 7/16" Sechskantantrieb DIN 3126 / ISO 1173 – E 11,2 *



Kreuzschlitz Phillips® – zähhart

Modell	Best.-Nr.	PH #	L mm	Ø mm	VE
PH2-E11-75	111310	2	75	6	10
PH3-E11-75	111311	3	75	8	10
PH4-E11-75	111312	4	75	10	10

Kreuzschlitz Pozidriv® – zähhart

Modell	Best.-Nr.	PZ #	L mm	Ø mm	VE
PZ2-E11-75	112310	2	75	6	10
PZ3-E11-75	112311	3	75	8	10
PZ4-E11-75	112312	4	75	10	10



Sechsrund Torx® – zähhart

Modell	Best.-Nr.	TX #	L mm	Ø mm	VE
T30-E11-60	113320	T30	60	–	10
T40-E11-60	113321	T40	60	–	10
T45-E11-60	113322	T45	60	–	10
T50-E11-60	113323	T50	60	–	10
T55-E11-60	113324	T55	60	–	10
T60-E11-60	113325	T60	60	–	10
T30-E11-75	113310	T30	75	6	10
T40-E11-75	113311	T40	75	–	10
T45-E11-75	113312	T45	75	8	10
T50-E11-75	113313	T50	75	10	10
T55-E11-75	113314	T55	75	12	10
T60-E11-75	113315	T60	75	14	10

Sechskant Inbus® – zähhart

Modell	Best.-Nr.	SW mm	L mm	Ø mm	VE
A4-E11-55	115310	4	55	5	10
A5-E11-55	115311	5	55	6	10
A6-E11-55	115312	6	55	7	10
A6-E11-55	115317	7	55	8	10
A8-E11-55	115313	8	55	10	10
A10-E11-55	115314	10	55	10	10
A12-E11-55	115315	12	55	14	10
A14-E11-55	115316	14	55	–	10
A6-E11-60	115320	6	60	–	10
A8-E11-60	115322	8	60	–	10
A10-E11-60	115324	10	60	–	10
A12-E11-60	115326	12	60	–	10
A14-E11-60	115328	14	60	–	10
A17-E11-60	115330	17	60	–	10
A5-E11-90	115321	5	90	6	10
A6-E11-90	115323	6	90	7	10
A7-E11-90	115325	7	90	8	10
A8-E11-90	115327	8	90	10	10
A10-E11-90	115329	10	90	12	10
A12-E11-90	115331	12	90	14	10



Vielzahn XZN – zähhart

Modell	Best.-Nr.	XZN #	L mm	Ø mm	VE
XZN10-E11-60	116303	M10	60	–	10
XZN5-E11-75	116310	M5	75	5	10
XZN6-E11-75	116311	M6	75	6	10
XZN8-E11-75	116312	M8	75	8	10
XZN10-E11-75	116313	M10	75	10	10
XZN12-E11-75	116314	M12	75	12	10
XZN14-E11-75	116315	M14	75	14	10

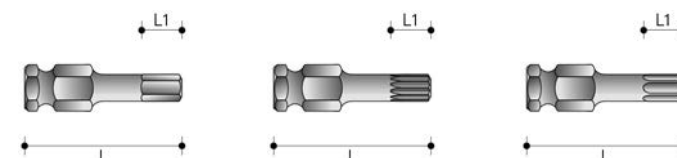

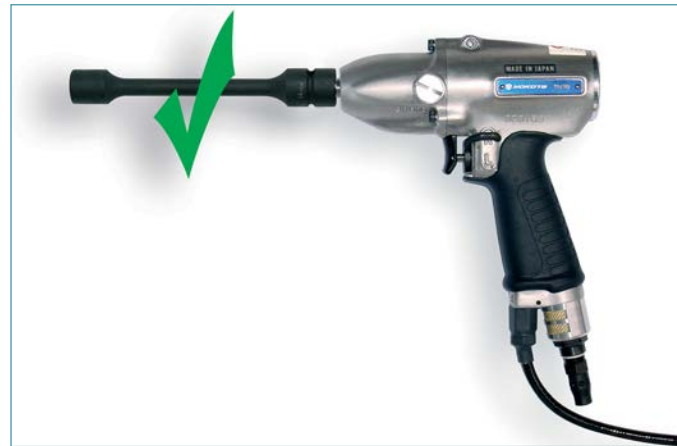

Spindelgeführte Kraftsteckschlüssel

Optimale Leistung und Sicherheit beim Arbeiten mit handgeführten **Impulsschraubern** erreicht man nur mit besonders geeigneten Kraftsteckschlüsseln und -verlängerungen.

Auf Wunsch des renommierten japanischen Impulsschrauber-Herstellers Yokota wurden die Kraftsteckschlüssel mit Spindelführung von Action® entwickelt, um die Qualität der Schraubverbindung mit Impulsschraubern weiter zu verbessern.

Action® Kraftsteckschlüssel mit Spindelführung bieten eine **exzellente Kraftübertragung**, da diese nicht allein auf dem Vierkanttrieb der Impulsschrauberachse sitzen, sondern zusätzlich vom runden Schaft der Antriebsspindel geführt werden. Dadurch haben diese speziellen Kraftsteckschlüssel ein **minimales Spiel zwischen Steckschlüssel und Antriebsspindel** des Schraubers. Nicht zuletzt vermeidet der "Sleeve-Drive" Antrieb die Übertragung von Schwingungen auf Mensch und Maschine.

Effekt: Durch die vertiefte Passung wird das „Wackeln“ reduziert, die Anzugsmomente werden noch genauer, Verschleiß stellt sich deutlich später ein, Geräuschpegel und Vibration werden reduziert, die Gesundheit des Werkers wird geschont.

Ein im Antriebsende der spindelgeführten Action® Kraftsteckschlüssel eingesetzter O-Ring optimiert den festen Sitz auf der Schrauberspindel und sorgt somit für die unmittelbare Weitergabe des vorgegebenen Drehmoments ohne nennenswerte Kraftverluste. Zudem wird die Lebensdauer des Steckschlüssels zusätzlich erhöht.

Wesentliche Pluspunkte

- Deutlich verbesserte Kraftübertragung durch geringere Drehmomentverluste
- Geringerer Verschleiß an Werkzeug und Schrauber
- Reduzierte Vibration
- Reduzierter Geräuschpegel
- Vermeidung von RSI, KTS u.ä.

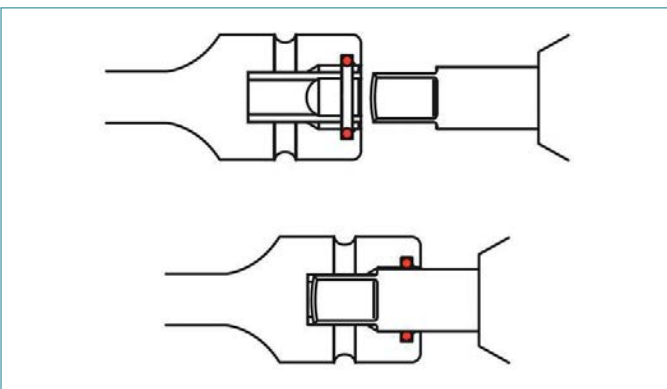

Anwender-Tipp

Verschlissene Steckschlüssel bewirken Kraftverlust und nutzen zudem den Antriebsvierkant des Werkzeugs ab. Dadurch entstehen auch zunehmende Vibrationen, was das Arbeiten belastet. Verschlissene Kraftsteckschlüssel sollte man deshalb frühzeitig auswechseln.

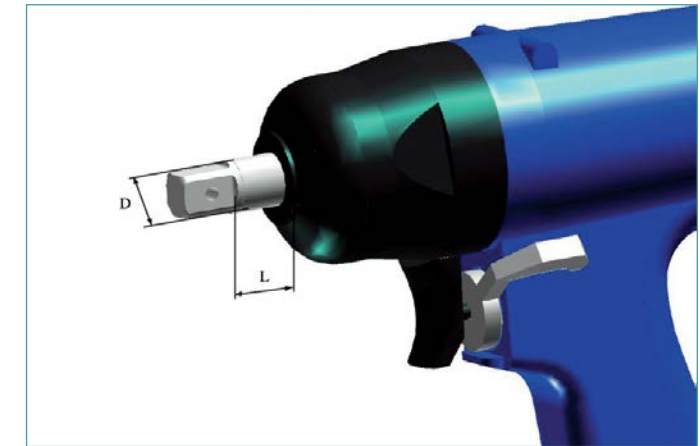
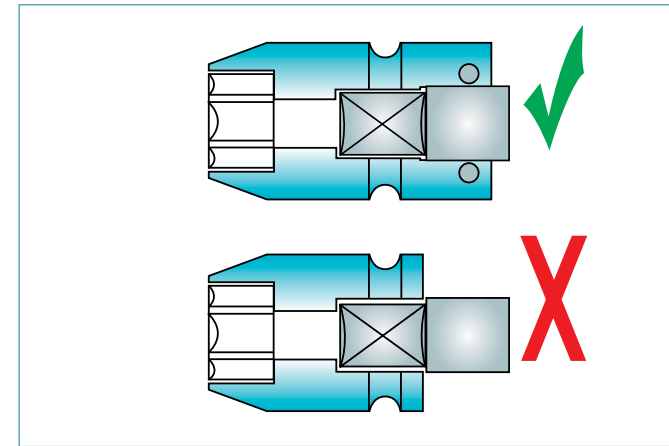

Vierkant Zoll	D mm	L mm
3/8	12	≥ 10
1/2	16	≥ 10
3/4	25	≥ 11.8

Action® Kraftsteckschlüssel mit Spindelführung können auf Impulsschraubern mit Antriebswellen der nebenstehenden Längen und Durchmesser gesteckt werden.

Alle Action® Kraftsteckschlüssel sind gemäß DIN 3121 und DIN 3129 gefertigt. Action® Kraftsteckschlüssel mit Spindelführung sind kompatibel mit allen Impulsschraubern der japanischen Anbieter Yokota und Uryu, wie auch anderer Fabrikate mit baugleicher Abtriebsgeometrie.

Vermeiden Sie „Surface-Drive“ Steckschlüssel

Wir raten unbedingt davon ab, „Surface Drive“ Steckschlüssel auf Impulsschraubern (egal, ob Standard-, Abschalt-, Akku- und/oder EC-) zu verwenden.

Stattdessen empfehlen wir, ausschließlich Kraftsteckschlüssel mit Standard-Sechskant, sowie nach Möglichkeit auch mit Spindelführung („Sleeve Drive“) zu benutzen.

- Das Spiel des „Surface Drive“ Sechskants (Bild 2 rechts) auf dem Schraubkopf kann die Drehmomentgenauigkeit beeinträchtigen.
- Es wird etwa die doppelte Anzahl Impulse benötigt, um das Zielmoment zu erreichen, da der Kraftfluss zwischen dem „Surface Drive“ und dem Schraubkopf erheblich kleiner ist als bei einem Standard-Sechskant (Bild 1).
- „Surface Drive“ verursacht höhere Vibrationen.
- „Surface Drive“ verursacht höhere Geräuschpegel.
- „Surface Drive“ verursacht einen schnelleren Verschleiß der Steckschlüssel.

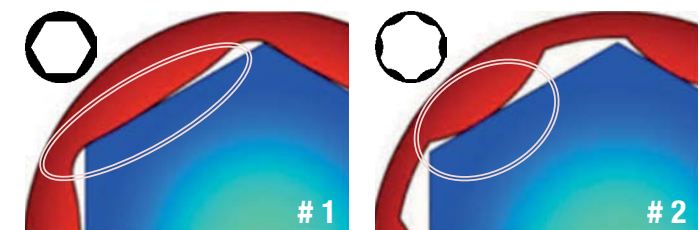

Standard-Sechskant:

Kleiner Radius in der Ecke, damit die Stecknuss an der flachen Seite des Schraubkopfes angreift und nicht an der Ecke. Größere Kontaktfläche sorgt für verbesserte Kraftübertragung.

Sechskant mit „Surface Drive“:

Großer Radius in der Ecke, um das Einrasten bei Schraubspindeln zu erleichtern. Bei kontinuierlich drehenden Antrieben hat das zusätzliche Spiel keinen Einfluss auf die Drehmomentgenauigkeit. Bei Impulsschraubern hingegen ist dieses zusätzliche Spiel sehr nachteilig, da es dann bei jedem Impuls zu einem Rückschlag kommt, anstatt eines kontinuierlichen Kontakts mit der Stecknuss. „Surface Drive“ Steckschlüssel sollten daher für Impulsschrauber nicht benutzt werden.



3/8 Kraftsteckschlüssel mit Spindelführung – für Impulsschrauber



Sechskant – normal

Modell	Best.-Nr.	SW mm	Form	L mm	D1 mm	D2 mm	L2 mm
KH3/8 - 6	300006	6	AS	43	11	19	5
KH3/8 - 8	300008	8	AS	43	13	19	7
KH3/8 - 9	300009	9	AS	43	15	19	7
KH3/8 - 10	300010	10	AS	43	16	19	8
KH3/8 - 11	300011	11	AS	43	17,5	19	9
KH3/8 - 12	300012	12	BS	43	19	19	9
KH3/8 - 13	300013	13	AS	43	20	22	9
KH3/8 - 14	300014	14	AS	43	21	22	9
KH3/8 - 15	300015	15	BS	43	22	22	11
KH3/8 - 16	300016	16	CS	43	24	22	11
KH3/8 - 17	300017	17	CS	43	25	22	11
KH3/8 - 18	300018	18	CS	43	26	22	11
KH3/8 - 19	300019	19	CS	43	27,5	22	11
KH3/8 - 21	300020	21	CS	43	30	22	13



Sechsrund Torx®

Modell	Best.-Nr.	SW #	Form	L mm	D1 mm	D2 mm	L2 mm
KH3/8-E5	300410	E5	AS	43	8	19	4,5
KH3/8-E6	300411	E6	AS	43	9	19	5
KH3/8-E7	300412	E7	AS	43	9,5	19	6
KH3/8-E8	300413	E8	AS	43	11	19	6,5
KH3/8-E10	300414	E10	AS	43	13	19	7,5
KH3/8-E11	300415	E11	AS	43	14	19	8
KH3/8-E12	300416	E12	AS	43	15,5	19	8,5
KH3/8-E14	300417	E14	AS	43	17,5	22	10
KH3/8-E16	300418	E16	AS	43	18,5	22	11



Sechskant – lang

Modell	Best.-Nr.	SW mm	Form	L mm	D1 mm	D2 mm	L2 mm
KH3/8-6-100	300050	6	DS	100	10,5	22	4
KH3/8-8-100	300051	8	DS	100	12,5	22	8
KH3/8-10-100	300052	10	DS	100	15	22	8
KH3/8-12-100	300053	12	DS	100	18	22	9
KH3/8-13-100	300054	13	DS	100	19	22	9
KH3/8-14-100	300055	14	DS	100	20	22	9
KH3/8-15-100	300056	15	DS	100	21	22	11
KH3/8-16-100	300057	16	DS	100	22,5	22	11
KH3/8-17-100	300058	17	DS	100	24	22	11
KH3/8-6-150	300110	6	DS	150	10,5	22	4
KH3/8-8-150	300111	8	DS	150	12,5	22	8
KH3/8-10-150	300112	10	DS	150	15	22	8
KH3/8-12-150	300113	12	DS	150	18	22	9
KH3/8-13-150	300114	13	DS	150	19	22	9
KH3/8-14-150	300115	14	DS	150	20	22	9
KH3/8-15-150	300116	15	DS	150	21	22	11
KH3/8-16-150	300117	16	DS	150	22,5	22	11
KH3/8-17-150	300118	17	DS	150	24	22	11
KH3/8-6-200	300150	6	DS	200	10,5	22	4
KH3/8-8-200	300151	8	DS	200	12,5	22	8
KH3/8-10-200	300152	10	DS	200	15	22	8
KH3/8-12-200	300153	12	DS	200	18	22	9
KH3/8-13-200	300154	13	DS	200	19	22	9
KH3/8-14-200	300155	14	DS	200	20	22	9
KH3/8-15-200	300156	15	DS	200	21	22	11
KH3/8-16-200	300157	16	DS	200	22,5	22	11
KH3/8-17-200	300158	17	DS	200	24	22	11
KH3/8-19-200	300159	19	DS	200	27	22	11

Form AS

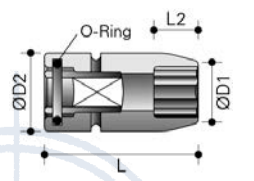

Form BS

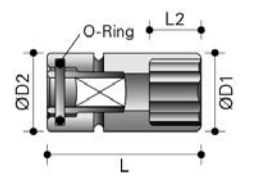

Form CS

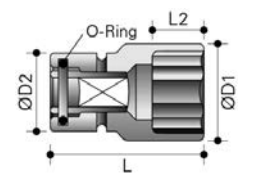

Form DS

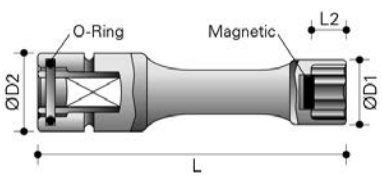

3/8 Kraftsteckschlüssel mit Spindelführung – für Impulsschrauber



Innensechskant Inbus®

Modell	Best.-Nr.	SW mm	Form	L mm	D1 mm	D2 mm	L1 mm
KHA3/8-3	300350	3	ES	75	-	22	11
KHA3/8-4	300351	4	ES	75	-	22	11
KHA3/8-5	300352	5	ES	75	-	22	11
KHA3/8-6	300353	6	ES	75	-	22	11
KHA3/8-7	300354	7	ES	75	-	22	16
KHA3/8-8	300355	8	ES	75	-	22	16
KHA3/8-9	300356	9	ES	75	-	22	16
KHA3/8-10	300357	10	ES	75	-	22	16
KHA3/8-11	300358	11	ES	75	-	22	16
KHA3/8-12	300359	12	ES	75	-	22	16
KHA3/8-13	300360	13	ES	75	-	22	16
KHA3/8-14	300361	14	ES	75	-	22	16
KHA3/8-15	300362	15	ES	75	-	22	16
KHA3/8-16	300363	16	ES	75	-	22	16



Innensechsrund Torx®

Modell	Best.-Nr.	SW #	Form	L mm	D1 mm	D2 mm	L1 mm
KH3/8-T9	300450	T9	ES	75	-	22	2
KH3/8-T10	300451	T10	ES	75	-	22	2,8
KH3/8-T15	300452	T15	ES	75	-	22	2,8
KH3/8-T20	300453	T20	ES	75	-	22	2,8
KH3/8-T25	300454	T25	ES	75	-	22	3
KH3/8-T27	300455	T27	ES	75	-	22	3
KH3/8-T30	300456	T30	ES	75	-	22	3,8
KH3/8-T40	300457	T40	ES	75	-	22	3,8
KH3/8-T45	300458	T45	ES	75	-	22	4,3
KH3/8-T47	300459	T47	ES	75	-	22	5
KH3/8-T50	300460	T50	ES	75	-	22	5
KH3/8-T55	300461	T55	ES	75	-	22	5

Form ES

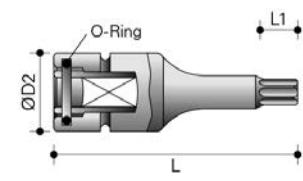

Weitere Infos auf unserer Website.

24/7

Weitere Infos auf unserer Website.

24/7

3/8 Kraftsteckschlüssel mit Spindelführung – für Impulsschrauber



Sechskant – mit Magnet

Modell	Best.-Nr.	SW mm	Form	L mm	D1 mm	D2 mm	L2 mm
KHM3/8 - 6	300023	6	AS	43	11	19	5
KHM3/8 - 7	300024	7	AS	43	12	19	5
KHM3/8 - 8	300025	8	AS	43	13	19	7
KHM3/8 - 9	300026	9	AS	43	15	19	7
KHM3/8 - 10	300027	10	AS	43	16	19	8
KHM3/8 - 11	300028	11	AS	43	17,5	19	9
KHM3/8 - 12	300029	12	BS	43	19	19	9
KHM3/8 - 13	300030	13	AS	43	20	22	9
KHM3/8 - 14	300031	14	AS	43	21	22	9
KHM3/8 - 16	300033	16	CS	43	24	22	11
KHM3/8 - 17	300034	17	CS	43	25	22	11
KHM3/8 - 18	300035	18	CS	43	26	22	11
KHM3/8 - 19	300036	19	CS	43	27	22	11
KHM3/8 - 20	300037	20	CS	43	28	22	13
KHM3/8 - 21	300038	21	CS	43	30	22	13
KHM3/8 - 22	300039	22	CS	50	31	22	13
KHM3/8 - 23	300040	23	CS	50	32	22	13
KHM3/8 - 24	300041	24	CS	50	34	22	13
KHM3/8 - 25	300042	25	CS	50	35	22	13
KHM3/8 - 26	300043	26	CS	50	36	22	13
KHM3/8 - 27	300044	27	CS	50	38	22	13



Sechskant – tief – mit Magnet

Modell	Best.-Nr.	SW mm	Form	L mm	D1 mm	D2 mm	L2 mm
KHM3/8-10T	300330	10	FS	100	16	19	5
KHM3/8-12T	300332	12	FS	100	18,5	19	6
KHM3/8-13T	300333	13	FS	100	20	22	6
KHM3/8-14T	300334	14	FS	100	21	22	6
KHM3/8-16T	300336	16	FS	100	24	22	7

Sechskant – lang – mit Magnet

Modell	Best.-Nr.	SW mm	Form	L mm	D1 mm	D2 mm	L2 mm
KHM3/8-6-100	300210	6	DS	100	11	19	3
KHM3/8-7-100	300211	7	DS	100	12	19	3
KHM3/8-8-100	300212	8	DS	100	13	19	4
KHM3/8-9-100	300213	9	DS	100	15	19	4
KHM3/8-10-100	300214	10	DS	100	16	19	4
KHM3/8-11-100	300215	11	DS	100	17,5	19	5
KHM3/8-12-100	300216	12	DS	100	18,5	19	5
KHM3/8-13-100	300217	13	DS	100	20	22	6
KHM3/8-14-100	300218	14	DS	100	21	22	6
KHM3/8-15-100	300219	15	DS	100	22	22	7
KHM3/8-16-100	300220	16	DS	100	24	22	7
KHM3/8-17-100	300221	17	DS	100	25	22	7
KHM3/8-8-150	300252	8	DS	150	13	19	4
KHM3/8-10-150	300254	10	DS	150	16	19	4
KHM3/8-11-150	300255	11	DS	150	17,5	19	5
KHM3/8-12-150	300256	12	DS	150	18,5	19	5
KHM3/8-13-150	300257	13	DS	150	20	22	6
KHM3/8-14-150	300258	14	DS	150	21	22	6
KHM3/8-15-150	300259	15	DS	150	22	22	7
KHM3/8-16-150	300260	16	DS	150	24	22	7
KHM3/8-17-150	300261	17	DS	150	25	22	7
KHM3/8-8-200	300312	8	DS	200	13	19	4
KHM3/8-9-200	300313	9	DS	200	15	19	4
KHM3/8-10-200	300314	10	DS	200	16	19	4
KHM3/8-12-200	300316	12	DS	200	18,5	19	5
KHM3/8-13-200	300317	13	DS	200	20	22	6
KHM3/8-14-200	300318	14	DS	200	21	22	6
KHM3/8-15-200	300319	15	DS	200	22	22	7

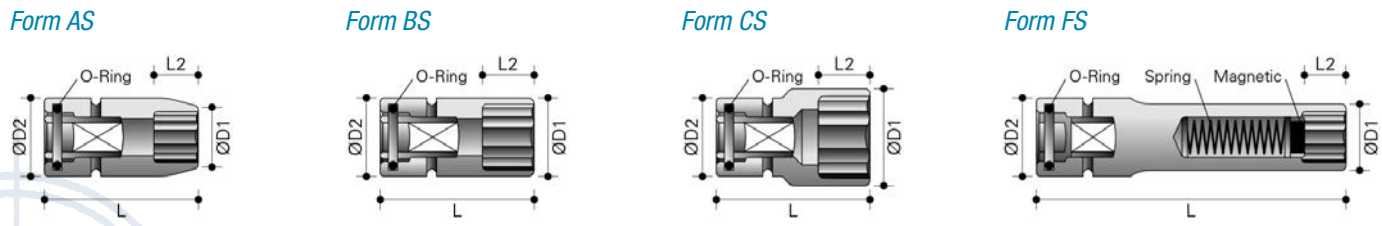

Weitere Infos auf unserer Website.

24/7

1/2 Kraftsteckschlüssel mit Spindelführung – für Impulsschrauber



Sechskant – normal

Modell	Best.-Nr.	SW mm	Form	L mm	D1 mm	D2 mm	L2 mm
KH1/2-12	310010	12	AS	52	20	25	12
KH1/2-13	310011	13	AS	52	21	25	12
KH1/2-14	310012	14	AS	52	22,5	25	12
KH1/2-15	310013	15	AS	52	23,7	30	12
KH1/2-16	310014	16	AS	52	25	30	12
KH1/2-17	310015	17	AS	52	26	30	12
KH1/2-18	310016	18	AS	52	27,5	30	12
KH1/2-19	310017	19	AS	52	28,7	30	12
KH1/2-21	310018	21	BS	52	30	30	12
KH1/2-22	310019	22	CS	52	32	30	12
KH1/2-23	310020	23	CS	52	32	30	12
KH1/2-24	310021	24	CS	52	35	30	12
KH1/2-25	310022	25	CS	57	36	30	12
KH1/2-27	310023	27	CS	57	39	30	12
KH1/2-30	310024	30	CS	62	42	30	12
KH1/2-32	310025	32	CS	62	44	30	12



Sechsrund Torx®

Modell	Best.-Nr.	SW #	Form	L mm	D1 mm	D2 mm	L2 mm
KH1/2-E10	310450	E10	AS	52	14	25	7,5
KH1/2-E11	310451	E11	AS	52	15	25	8
KH1/2-E12	310452	E12	AS	52	16	25	8,5
KH1/2-E14	310453	E14	AS	52	18	25	10
KH1/2-E16	310454	E16	AS	52	20	25	11
KH1/2-E18	310455	E18	AS	52	22	25	12,5
KH1/2-E20	310456	E20	AS	52	25	30	14
KH1/2-E22	310457	E22	AS	52	27	30	15
KH1/2-E24	310458	E24	AS	52	29	30	16,5

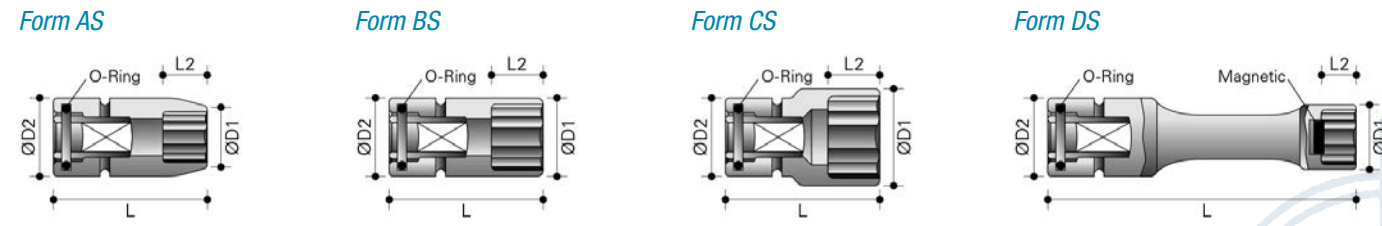

Weitere Infos auf unserer Website.

24/7

1/2 Kraftsteckschlüssel mit Spindelführung – für Impulsschrauber



Innensechskant Inbus®

Modell	Best.-Nr.	SW mm	Form	L mm	D1 mm	D2 mm	L1 mm
KHA1/2-3	310350	3	ES	75	-	25	11
KHA1/2-4	310351	4	ES	75	-	25	11
KHA1/2-5	310352	5	ES	75	-	25	15
KHA1/2-6	310353	6	ES	75	-	25	15
KHA1/2-7	310354	7	ES	75	-	25	20
KHA1/2-8	310355	8	ES	75	-	25	25
KHA1/2-9	310356	9	ES	75	-	25	25
KHA1/2-10	310357	10	ES	75	-	25	25
KHA1/2-11	310358	11	ES	75	-	25	25
KHA1/2-12	310359	12	ES	75	-	25	25
KHA1/2-13	310360	13	ES	75	-	25	25
KHA1/2-14	310361	14	ES	75	-	25	25
KHA1/2-15	310362	15	ES	75	-	25	25
KHA1/2-16	310363	16	ES	75	-	25	25
KHA1/2-17	310364	17	ES	75	-	25	25
KHA1/2-18	310365	18	ES	75	-	25	25
KHA1/2-19	310366	19	ES	75	-	25	25

Innensechsrund Torx®

Modell	Best.-Nr.	SW #	Form	L mm	D1 mm	D2 mm	L1 mm
KH1/2-T20	310510	T20	ES	75	-	25	2,8
KH1/2-T25	310511	T25	ES	75	-	25	3
KH1/2-T27	310512	T27	ES	75	-	25	3
KH1/2-T30	310513	T30	ES	75	-	25	3,8
KH1/2-T40	310514	T40	ES	75	-	25	3,8
KH1/2-T45	310515	T45	ES	75	-	25	4,3
KH1/2-T47	310516	T47	ES	75	-	25	5
KH1/2-T50	310517	T50	ES	75	-	25	5
KH1/2-T55	310518	T55	ES	75	-	25	5,5
KH1/2-T60	310519	T60	ES	75	-	25	8
KH1/2-T70	310520	T70	ES	75	-	25	9,4
KH1/2-T80	310521	T80	ES	75	-	25	10,5
KH1/2-T90	310522	T90	ES	75	-	25	11,8
KH1/2-T100	310523	T100	ES	75	-	25	13,1

Form ES

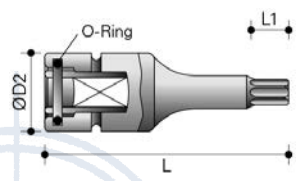

Weitere Infos auf unserer Website.



1/2 Kraftsteckschlüssel mit Spindelführung – für Impulsschrauber



Sechskant – mit Magnet

Modell	Best.-Nr.	SW mm	Form	L mm	D1 mm	D2 mm	L2 mm
KHM1/2-6	310406	6	AS	52	13	25	5
KHM1/2-7	310407	7	AS	52	14	25	5
KHM1/2-8	310408	8	AS	52	15	25	7
KHM1/2-9	310409	9	AS	52	16	25	7
KHM1/2-10	310410	10	AS	52	17,5	25	8
KHM1/2-11	310411	11	AS	52	18,5	25	9
KHM1/2-12	310412	12	BS	52	20	25	12
KHM1/2-13	310413	13	AS	52	21	25	12
KHM1/2-14	310414	14	AS	52	22,5	25	12
KHM1/2-15	310415	15	AS	52	23,5	30	12
KHM1/2-16	310416	16	AS	52	25	30	12
KHM1/2-17	310417	17	AS	52	26	30	12
KHM1/2-18	310418	18	AS	52	27,5	30	12
KHM1/2-19	310419	19	AS	52	28,5	30	12
KHM1/2-20	310420	20	BS	52	30	30	12
KHM1/2-21	310421	21	CS	52	31	30	12
KHM1/2-22	310422	22	CS	52	32	30	12
KHM1/2-23	310423	23	CS	52	34	30	12
KHM1/2-24	310424	24	CS	52	35	30	12
KHM1/2-25	310425	25	CS	57	36	30	12
KHM1/2-26	310426	26	CS	57	38	30	12
KHM1/2-27	310427	27	CS	57	38,5	30	12

Sechskant – tief – mit Magnet

Modell	Best.-Nr.	SW mm	Form	L mm	D1 mm	D2 mm	L2 mm
KHM1/2-10T	310330	10	FS	100	17,5	25	5
KHM1/2-13T	310333	13	FS	100	21	25	6
KHM1/2-16T	310336	16	FS	100	25	30	7
KHM1/2-17T	310337	17	FS	100	26	30	7
KHM1/2-19T	310339	19	FS	100	28,5	30	8

Form AS

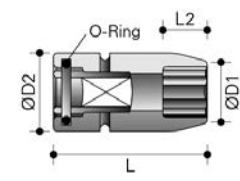

Form BS

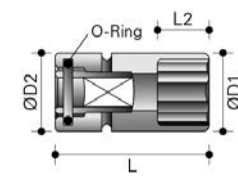

Form CS

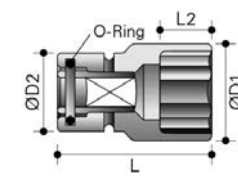

Form FS

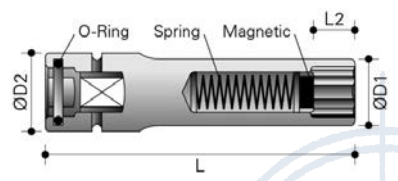

Form DS

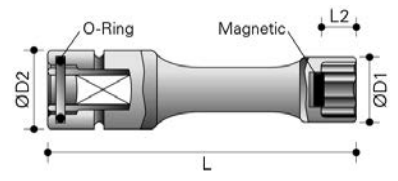

Weitere Infos auf unserer Website.



Sechskant – normal

Modell	Best.-Nr.	SW mm	Form	L mm	D1 mm	D2 mm	L2 mm
KH3/4-17	311010	17	AS	65	31	44	12
KH3/4-18	311011	18	AS	65	32	44	12
KH3/4-19	311012	19	AS	65	33	44	14
KH3/4-21	311013	21	AS	65	35	44	16
KH3/4-22	311014	22	AS	65	37	44	16
KH3/4-23	311015	23	AS	65	38	44	16
KH3/4-24	311016	24	AS	65	39	44	16
KH3/4-26	311017	26	AS	65	41	44	16
KH3/4-27	311018	27	AS	65	43	44	16
KH3/4-28	311019	28	BS	68	44	44	20
KH3/4-29	311020	29	CS	68	45	44	20
KH3/4-30	311021	30	CS	68	47	44	20
KH3/4-32	311022	32	CS	70	49	44	20
KH3/4-33	311023	33	CS	70	51	44	20
KH3/4-34	311024	34	CS	70	52	44	20
KH3/4-35	311025	35	CS	70	53	44	20
KH3/4-36	311026	36	CS	70	54	44	20
KH3/4-38	311027	38	CS	72	57	44	22
KH3/4-41	311028	41	CS	72	60	44	22
KH3/4-46	311029	46	CS	77	67	54	23
KH3/4-50	311030	50	CS	77	71	54	23



Sechsrund Torx®

Modell	Best.-Nr.	SW #	Form	L mm	D1 mm	D2 mm	L2 mm
KH3/4-E18	311150	E18	AS	65	26	44	12,5
KH3/4-E20	311151	E20	AS	65	28	44	14
KH3/4-E22	311152	E22	AS	65	31	44	15
KH3/4-E24	311153	E24	AS	65	33	44	16,5

Form AS

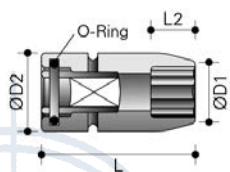

Form BS

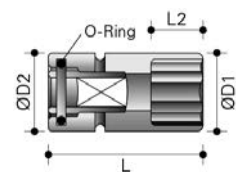

Form CS

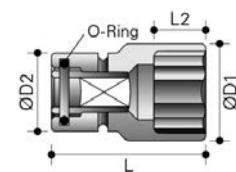

Form ES

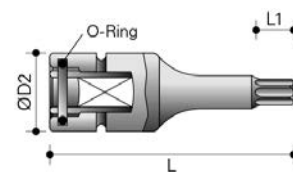

Sechskant – mit Magnet

Modell	Best.-Nr.	SW mm	Form	L mm	D1 mm	D2 mm	L2 mm
KHM3/4-13	311213	13	AS	65	24,5	44	12
KHM3/4-14	311214	14	AS	65	25,5	44	12
KHM3/4-15	311215	15	AS	65	27	44	12
KHM3/4-16	311216	16	AS	65	28	44	12
KHM3/4-17	311217	17	AS	65	30	44	12
KHM3/4-18	311218	18	AS	65	31	44	12
KHM3/4-19	311219	19	AS	65	32	44	14
KHM3/4-20	311220	20	AS	68	34	44	14
KHM3/4-21	311221	21	AS	68	35	44	16
KHM3/4-22	311222	22	AS	68	37	44	16
KHM3/4-23	311223	23	AS	68	38	44	16
KHM3/4-24	311224	24	AS	68	39	44	16
KHM3/4-25	311225	25	AS	69	41	44	16
KHM3/4-26	311226	26	AS	69	42	44	16
KHM3/4-27	311227	27	AS	69	43	44	16



Innensechskant Inbus®

Modell	Best.-Nr.	SW mm	Form	L mm	D1 mm	D2 mm	L1 mm
KHA3/4-10	311110	10	ES	100	-	44	20
KHA3/4-12	311111	12	ES	100	-	44	20
KHA3/4-14	311112	14	ES	100	-	44	20
KHA3/4-16	311113	16	ES	100	-	44	20
KHA3/4-17	311114	17	ES	100	-	44	20
KHA3/4-19	311115	19	ES	100	-	44	20
KHA3/4-22	311116	22	ES	100	-	44	20
KHA3/4-24	311117	24	ES	100	-	44	20
KHA3/4-27	311118	27	ES	100	-	44	20
KHA3/4-30	311119	30	ES	100	-	44	20
KHA3/4-32	311120	32	ES	100	-	44	20
KHA3/4-33	311121	33	ES	100	-	44	20
KHA3/4-36	311122	36	ES	100	-	44	20
KHA3/4-38	311123	38	ES	100	-	44	20

Weitere Infos auf unserer Website.

24/7



Verlängerungen

Modell	Best.-Nr.	4kt Zoll	Form	L mm	D1 mm	D2 mm	L1 mm
KHV 3/8-75	312010	3/8	SX	75	-	22	-
KHV 3/8-125	312011	3/8	SX	125	-	22	-
KHV 3/8-250	312012	3/8	SX	250	-	22	-
KHV 1/2-75	312013	1/2	SX	75	-	25	-
KHV 1/2-125	312014	1/2	SX	125	-	25	-
KHV 1/2-175	312015	1/2	SX	175	-	25	-
KHV 1/2-250	312016	1/2	SX	250	-	25	-
KHV 3/4-175	312017	3/4	SX	175	-	44	-
KHV 3/4-250	312018	3/4	SX	250	-	44	-
KHV 3/4-330	312019	3/4	SX	330	-	44	-



Gummiring und Sicherungsstift

Modell	Best.-Nr.	4kt Zoll	Form	L mm	D1 mm	D2 mm	L2 mm
RS-3/8	222050	3/8	-	-	-	-	-
RS-1/2	240510	1/2	-	-	-	-	-
RS-3/4	250810	3/4	-	-	-	-	-

Form SX

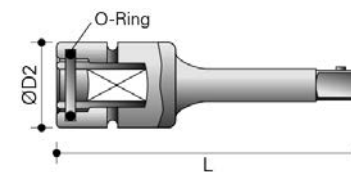

Weitere Infos auf unserer Website.

24/7



Schnellwechsel-Adapter





Modell	Best.-Nr.	E Zoll	A Zoll	L mm	D1 mm	D2 mm	L1 mm
KHQC3/8-3/8	314511	3/8	3/8	75	-	19	-
KHQC3/8-3/8L	314514	3/8	3/8	100	-	19	-
KHQC3/8-1/2	314509	3/8	1/2	80	-	20	-
KHQC1/2-3/8	314512	1/2	3/8	75	-	25	-
KHQC1/2-1/2	314513	1/2	1/2	100	-	25	-
KHQC3/4-1/2	314510	3/4	1/2	90	-	44	-
KHQC3/4-3/4	314515	3/4	3/4	125	-	44	-





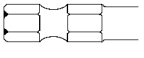
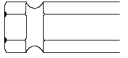
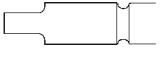
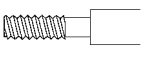

Schnellwechsel-Bithalter

Modell	Best.-Nr.	E Zoll	A Zoll	L mm	D1 mm	D2 mm	L2 mm
KHQC3/8-H1/4	313585	3/8	1/4	52	-	22	-
KHQC3/8-H7/16	313591	3/8	7/16	62	-	22	-
KHQC1/2-H1/4	313583	1/2	1/4	60	-	25	-
KHQC1/2-H7/16	313593	1/2	7/16	70	-	25	-
KHQC3/4-H7/16	313595	3/4	7/16	80	-	44	-



Zuordnung von Werkzeugantrieb und Maschine

Antriebsgröße	Antriebsform	Norm	Anschluss	Hersteller entsprechender Maschinenschrauber
1/4" Sechskant mit Kerbe		DIN 3126 ISO 1173 Form C 6,3	Universal-Bithalter oder direkter Maschinenanschluss (s.r.)	Bosch, Fein, Holz-Her, Lecureux, Metabo
5/16" Sechskant mit Kerbe		DIN 3126 ISO 1173 Form C 8	Universal-Bithalter oder direkter Maschinenanschluss (s.r.)	Bosch, Fein, Holz-Her, Lecureux, Metabo
1/4" Sechskant mit Rille		DIN 3126 ISO 1173 Form E 6,3	Kombi-Bithalter oder direkter Maschinenanschluss (s.r.)	AEG, Atlas-Copco, Biax, Black & Decker, Bosch, Chicago Pneumatic, Cleco, Deprag, Desoutter, Fiam, Hitachi, Ingersoll-Rand, Makita, Metabo, Panasonic, Red Rooster, Rockwell, Skil, Stanley, Tohnichi, Uryu, Virax, Yokota
7/16" Sechskant mit Rille		DIN 3126 ISO 1173 Form E 11,2	Direkter Maschinenanschluss (s.r.)	AEG, Atlas-Copco, Biax, Black & Decker, Bosch, Chicago Pneumatic, Fein, Holz-Her, Ingersoll-Rand, Milwaukee, Rotor Tool, Star, Stanley, Virax
7 mm Flachkant		DIN 3126 Form G 7	Direkter Maschinenanschluss (s.r.)	Baier, Fein
5,5 mm Sechskant und Rille	–	DIN 3126 ISO 1173 Form A 5,5	Direkter Maschinenanschluss (s.r.)	AEG, Bosch, Holz-Her, Kress, Metabo
M4 - M6, 10-32 UNF Gewinde		–	Direkter Maschinenanschluss (s.r.)	Böllhoff/Uniquick, Holz-Her, DVSG, Duofast, USM, Weber
SDS-plus®		–	Direkter Maschinenanschluss (s.r.)	AEG, Atlas-Copco, Bosch, Hitachi, Kress, Metabo

Prüfdrehmomente für Schraubwerkzeuge

Schlitz-Profil		Innensechskant (Inbus®)		Sechsrund (Torx®)		Sechsrund (Torx®) Tamper	
	N·m*		N·m*		N·m*		N·m*
0,3 × 2,0	0,20	0,7	0,08	TX 1	0,1	TR 7	1,4
0,4 × 2,0	0,35	0,9	0,18	TX 2	0,14	TR 8	2,2
0,4 × 2,5	0,45	1,3	0,53	TX 3	0,25	TR 9	2,9
0,5 × 3,0	0,80	1,5	0,82	TX 4	0,37	TR 10	3,8
0,5 × 3,5	0,98	2,0	1,9	TX 5	0,51	TR 15	6,5
0,6 × 3,5	1,40	2,5	3,8	TX 6	0,91	TR 20	10,8
0,6 × 4,0	1,61	3	6,6	TX 7	1,7	TR 25	16,1
0,6 × 4,5	1,80	3,5	11	TX 8	2,6	TR 27	22,9
0,8 × 4,0	2,90	4	16	TX 9	3,4	TR 30	31,8
0,8 × 5,0	3,58	4,5	24	TX 10	4,5	TR 40	55,3
0,8 × 5,5	3,90	5	30	TX 15	7,7	TR 45	88
1,0 × 5,5	6,20	6	52	TX 20	12,7	TR 50	135
1,0 × 6,5	7,28	7	78	TX 25	19,0	TR 55	218
1,0 × 7,0	7,80	8	120	TX 27	26,9	TR 60	379
1,2 × 6,5	10,50	9	180	TX 30	37,4	TR 70	596
1,2 × 7,0	11,28	10	220	TX 40	65,1		
1,2 × 8,0	12,90	11	295	TX 45	104		
1,4 × 9,0	19,70	12	370	TX 50	159		
1,5 × 13	32	13	480	TX 55	257		
1,6 × 8,0	22,90	14	590	TX 60	445		
1,6 × 9,0	25	17	1000	TX 70	701		
1,6 × 10	28,70	19	1000				
2,0 × 12	53	22	1000				
2,0 × 13	58	24	1000				
2,5 × 14	98	27	1000				
2,5 × 16	112						
3,0 × 18	181						

Kreuzschlitz PH und PZ

		N·m*
0		1,0
1		3,9
2		10,3
3		32,0
4		88,7

Schlitz-Profil: Entsprechend DIN 5264, ISO 2380 und SMS-SS 2223. Die Prüfdrehmomente wurden auf einer Drehmomentprüfeinrichtung mit den entsprechenden Prüfscheiben gemäß DIN 5263 ermittelt.

Kreuzschlitz-Profil: Entsprechend DIN 5260, ISO 8764 und SMS-SS 1687. Die Prüfdrehmomente wurden auf einer Drehmomentprüfeinrichtung mit den entsprechenden Prüfscheiben gemäß DIN 5261, ISO 8764 ermittelt.

Innensechskant-Profil: Entsprechend DIN 911 und ISO 2936. Die Prüfdrehmomente wurden auf einer Drehmomentprüfeinrichtung mit den entsprechenden Prüfscheiben gemäß DIN 911 ermittelt.

Sechsrund-Profil: Die Prüfdrehmomente wurden ermittelt mit den entsprechenden Prüfscheiben des TX-Lizengebers (Camcar Textron) auf einer Drehmomentprüfeinrichtung entsprechend DIN 5261.

* Die genannten Drehmomentwerte gelten nur für den maschinellen Anzug.



Umrechnen von Drehmomentwerten

von Einheit	multipliziert mit	entspricht
Ounce-force inch (ozf-in), ugs. auch: Inch-Ounce (in-oz)	0,706156	cN·m
	0,072007	kgf·cm (kp·cm) *
	0,0625	lbf-in
Pound-force inch (lbf-in), ugs. auch: Inch-Pound (in-lb)	11,298483	cN·m
	1,1298483	dN·m
	0,11298483	N·m
	1,1521246	kgf·cm (kp·cm) *
	0,011521246	kgf·m (kp·m) *
	16	ozf-in
Pound-force foot (lbf-ft), ugs. auch: Foot-Pound (ft-lb)	0,083333333	lbf-ft
	1,35581795	N·m
	13,5581795	dN·m
	135,581795	cN·m
	0,13825495	kgf·m (kp·m) *
	13,825495	kgf·cm (kp·cm) *
	12	lbf-in
	192	ozf-in
	9,80665	N·m
Kraftkilogramm-Meter (kgf-m), * Kilopondmeter (kp-m) *	98,0665	dN·m
	980,665	cN·m
	7,2330139	lbf-ft
	86,796166	lbf-in
	0,0980665	N·m
Kraftkilogramm-Zentimeter (kgf-cm), * Kilopondzentimeter (kp-cm) *	0,980665	dN·m
	9,80665	cN·m
	0,072330139	lbf-ft
	0,86796166	lbf-in
	0,10197162	N·m
Newtonmeter (N·m)	10,197162	kgf·cm (kp·cm) *
	8,8507458	lbf-in
	0,73756215	lbf-ft
	10	dN·m
	100	cN·m
	14,161184	ozf-in
Dezi-Newtonmeter (dN·m)	0,88507458	lbf-in
	0,1	N·m
	10	cN·m
Zenti-Newtonmeter (cN·m)	1,4161184	ozf-in
	0,088507458	lbf-in
	0,1	dN·m
	0,01	N·m

* Die veralteten Einheiten Kraftkilogramm bzw. Kilopondmeter werden hier lediglich zum Zwecke der Konvertierbarkeit aufgeführt. Die gültige SI-konforme Einheit ist das Newtonmeter, wobei im Angelsächsischen die auf Foot, Inch oder Ounce basierenden Einheiten in der Praxis meist bevorzugt werden.

Richtwerte für Anzugsmomente entsprechend DIN 13

Nenn- grösse	SW innen mm	SW ausser mm	Reibungs- koeffizient μ	Anzugsmoment M_A für Schraubenfertigungs-kategorie nach DIN 267, ISO 898/1					
				3.6 N·m	5.6 N·m	6.9 N·m	8.8 N·m	10.9 N·m	12.9 N·m
M 2	-	4	0,10	-	-	0,26	0,32	0,47	0,55
			0,14	-	-	0,31	0,38	0,56	0,65
M 3	-	5,5	0,10	0,30	0,51	0,81	1,1	1,5	1,8
			0,14	0,37	0,62	0,99	1,3	1,9	2,2
M 4	3	7	0,10	0,70	1,2	1,9	2,4	3,3	4,0
			0,14	0,85	1,4	2,3	2,9	4,1	4,9
M 5	4	8-9	0,10	1,4	2,3	3,6	4,9	7,0	8,0
			0,14	1,7	2,8	4,5	6,0	8,5	10
M 6	5	10	0,10	2,4	3,9	6,3	8,0	12	14
			0,14	2,9	4,8	7,7	10	14	17
M 8	6	13-14	0,10	5,7	9,5	15	20	28	34
			0,14	7,0	12	19	25	35	41
M 10	8	15-17	0,10	11	19	30	40	56	67
			0,14	14	23	37	49	69	83
M 12	10	19-21	0,10	20	33	52	69	98	115
			0,14	24	40	65	86	120	145
M 14	12	22-23	0,10	31	52	83	110	155	185
			0,14	39	64	105	135	190	230
M 16	14	24-26	0,10	48	79	125	170	240	285
			0,14	59	98	155	210	295	355
M 18	14	27	0,10	66	110	175	235	330	395
			0,14	81	135	215	290	405	485
M 20	17	30	0,10	92	155	245	330	465	560
			0,14	115	190	305	410	580	690
M 22	17	34	0,10	125	205	330	445	620	750
			0,14	165	260	415	550	780	930
M 24	19	36	0,10	160	265	425	570	800	960
			0,14	200	330	530	710	1000	1200
M 27	-	41	0,10	235	390	630	840	1200	1400
			0,14	295	490	780	1050	1500	1800
M 30	-	46	0,10	320	530	850	1150	1600	1950
			0,14	395	660	1050	1450	2000	2400
M 33	-	50	0,10	430	720	1150	1550	2150	2600
			0,14	540	900	1450	1900	2700	3250
M 36	-	55	0,10	550	920	1500	1950	2750	3300
			0,14	690	1150	1850	2450	3450	4150



Produktgruppen

● Drehmomentwerkzeuge

- auslösend
- anzeigend
- elektronisch überwacht

● Impulsschraubtechnik

- Akku-Impulsschrauber
- DL-Impulsschrauber
- EC-Schraubsysteme

● Drehmomentmesstechnik

- Messuhren
- Prüfgeräte & Sensoren
- Kalibrierequipment

● Druckluftzangen

- Schneidzangen
- Montagezangen
- Automatenzangen

● Kraftsteckschlüssel

- ohne/mit Magnet
- mit Spindelführung
- Verbindungsteile

● Schrauber-Bits

- Bits & Halter
- Nutsetter
- Adapter

● Luftleitung & Zubehör

- Luftaufbereitung
- Schläuche & Kupplungen
- Seilfederzüge & Balancer

Vorliegender Katalog ersetzt alle vorangegangenen Ausgaben. Bilder und technische Angaben entsprechen dem Stand vor Drucklegung. Irrtum/Änderungen vorbehalten.

Ausgabe: 2022-2023



ZEMO Vertriebs GmbH

Ausschläger Weg 41

20537 Hamburg (Germany)

T: +49 (0)40 303 989 100

M: info@zemo-tools.de

W: www.zemo-tools.de

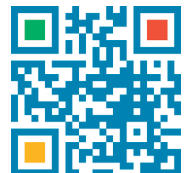

ZEMO

www.zemo-tools.de

Edit 2023.25