

LEGEND: () = QUANTITY/TOOL
 * = QUANTITY/MULTI-PAK

820042 - CARTON
 857331 - INSTRUCTIONS

10616 (1)
 RADIO KIT 2.4GHz; AAA FOR LARGE SLTC-FM
 WRENCHES (INCLUDES AAA BATTERY HOUSING
 UPPER & LOWER COVERS, BATTERY HOUSING
 LID, RADIO 2.4GHz AAA, RUBBER WASHERS,
 SCREW PAN HEAD, LITEPIPE & SPRING CLIP,
 PCB INSULATION, SLTC LABEL, & AAA BATTERY

NOTES:
 1. TIGHTEN TO 1.5-2.5 IN. LBS. AND APPLY
 A DROP OF ADHESIVE (PERMA-LOK
 MM115 OR LOCTITE 262) TO SET SCREW
 (816767) PRIOR TO ASSEMBLY INTO
 TANG (811359)

WARNING: USE ONLY 1.5 VDC ALKALINE OR
 1.2 VDC NiMH AAA RECHARGEABLE
 BATTERIES. OTHER BATTERIES CAN CAUSE
 DAMAGE TO THE BOARD AND IMPACT RADIO
 SIGNAL.

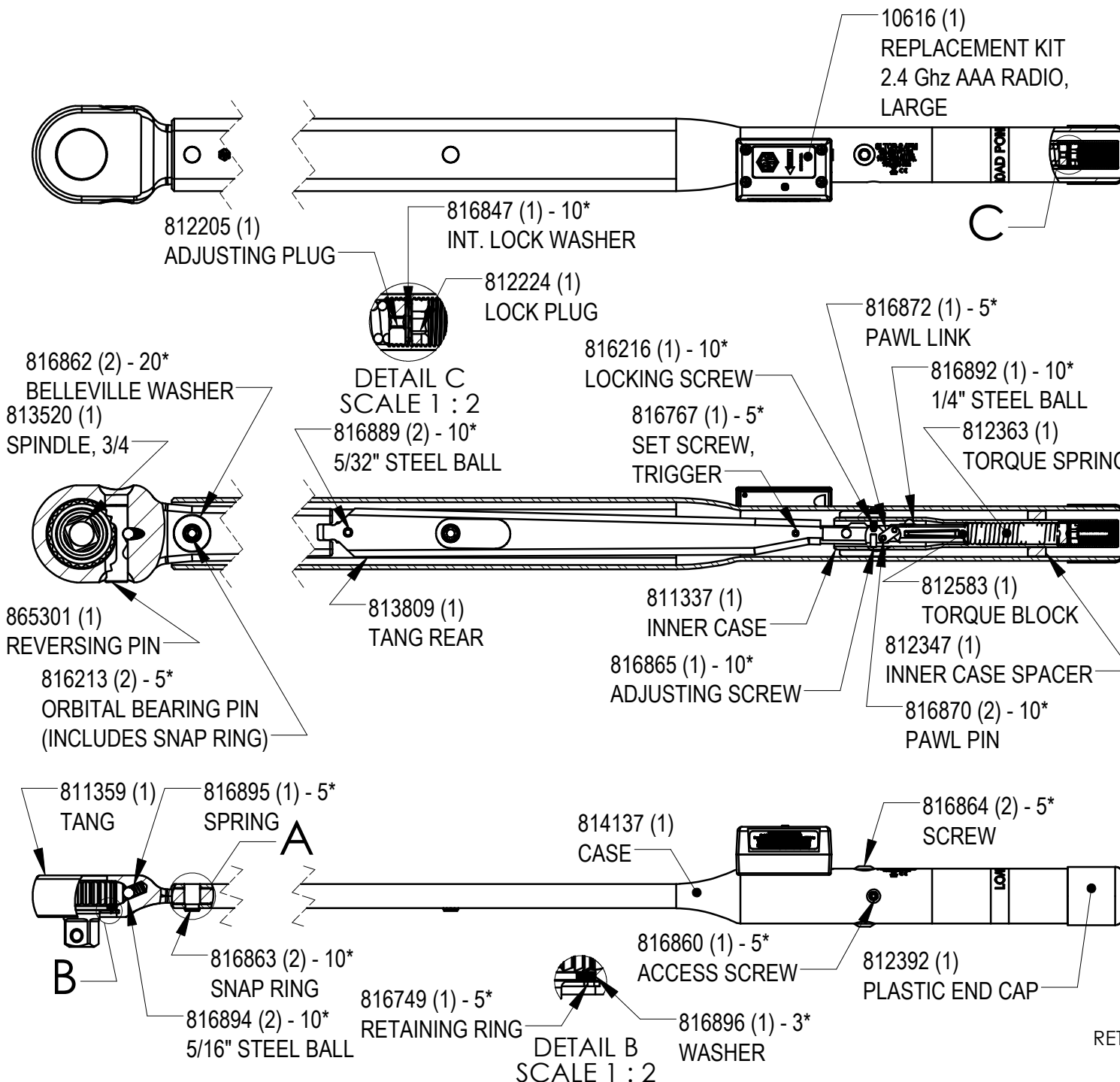

DETAIL A
 SCALE 1 : 2
 DEFORM BEFORE
 CALIBRATION

