

Rotary Transducers – CheckStar Multi



Compatible with IQVu (Plus)

Rotating torque sensor with tri-colour light ring and high resolution angle encoder

The CheckStar Multi is the latest generation of Crane Electronics market leading CheckStar in line rotary torque transducer. It raises the standard for dynamic torque and angle measurement of all continuous drive and impulse tools, with proven reliable performance in thousands of applications worldwide.

The CheckStar Multi fits in-line between the assembly tool and the fastener, measuring the actual torques applied and angular rotation of the fastener, under production conditions. If angle is specified, the CheckStar Multi rotary torque transducer will include an angle encoder giving 0.125° resolution (720 PPR). It also incorporates a light ring, giving the user visual feedback of the status of a tightening, when used with a Crane readout or data collector.

Whatever the vibration and shock loads experienced, CheckStar Multi's patented contact system ensures a connection is always maintained between the readout and the strain gauges. Inferior systems suffer from "brush bounce" that leads to unreliable torque readings.

The low inertia design of the CheckStar Multi ensures accurate and repeatable measurement of high speed transients, such as the point of shut-off on continuous drive tools and the pulsing of impulse tools.

Using on-board intelligence the CheckStar Multi is automatically recognised by a Crane data collector or readout device, eliminating set-up errors and enabling logging of serial number against measurements for complete traceability.

The CheckStar Multi can also be used where a user needs the advanced features of the transducer but already has a data collector or readout device from another manufacturer.

- ▶ Measurement accuracy $\pm 0.25\%$ of capacity (right/left).
- ▶ High-resolution angle encoder (0,125°)
- ▶ Zero stability $< \pm 0,1\%$ FSD/°C.
- ▶ Patented slip ring contact system prevents „brush bounce“.
- ▶ Suitable for all continuously rotating tools, impulse tools and torque wrenches.
- ▶ Compatible with most industry standard measuring devices.
- ▶ Auto-Ident on Crane data collectors.
- ▶ Easily visible light ring showing status in three colors (in conjunction with IQVu).
- ▶ Rugged and durable construction, aluminum housing, stainless steel shaft.
- ▶ Ingress Protection IP40.
- ▶ Traceable factory calibration certificate.
- ▶ Output interface acc. to MIL-C-26482 / BS 9522 - F0017, type 14-19S.
- ▶ Connection to the measuring device optionally via optional signal cable or via optional RFm radio module*.



Compatible with TorqueStar Plus/Pro



Compatible with TorqueStar Lite



Compatible with Table Top Joint Kits

Options

INFO

- C718620 = RFm* radio module (for CheckStar Multi only)
- C718259 = Signal cable D-Sub 25
- C718321 = 5-way Auto T-Switch



Img.: RFm



Img. left: Optional Auto Transducer Switch 5-way sensor switch for Crane UTA or Multi sensors. An LED indicates the currently active transducer. The connected Crane meter then suggests the most suitable sensor.



Img. left: CheckStar Multi with radio module „RFm“ for wireless communication with the measuring device.

- RF 2.4 GHz (GFSK)
- Buffer memory for 200 readings
- Li-Ion battery 3.7 V
- Protection IP40

* Compatible with Crane data collectors IQVu, TCI, TCI Multi and TorqueStar Pro.



Rotary Transducers – CheckStar Multi

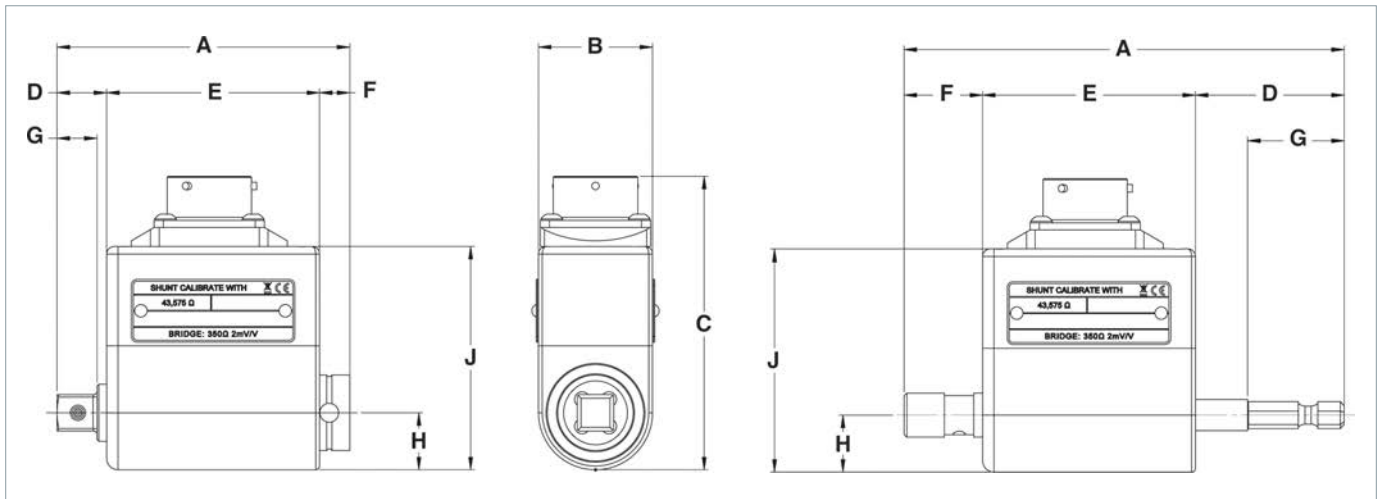

CheckStar Multi

Model	Art.-Nr.	Range N·m	Angle encoder	Dimensions (mm)									hex inch	sqd inch	Weight kg
				A	B	C	D	E	F	G	H	J			
Hex CS Multi 1 Nm	C718607	0.1 - 1	–	116	30	73	39	56	21	26	13	55	1/4	–	0.21
Hex CS Multi 1 Nm + Angle	C718640	0.1 - 1	•	116	30	73	39	56	21	26	13	55	1/4	–	0.21
Hex CS Multi 2 Nm	C718621	0.2 - 2	–	116	30	73	39	56	21	26	13	55	1/4	–	0.21
Hex CS Multi 2 Nm + Angle	C718641	0.2 - 2	•	116	30	73	39	56	21	26	13	55	1/4	–	0.21
Hex CS Multi 5 Nm	C718622	0.5 - 5	–	116	30	73	39	56	21	26	13	55	1/4	–	0.21
Hex CS Multi 5 Nm + Angle	C718642	0.5 - 5	•	116	30	73	39	56	21	26	13	55	1/4	–	0.21
Hex CS Multi 10 Nm	C718623	1 - 10	–	116	30	73	39	56	21	26	13	55	1/4	–	0.21
Hex CS Multi 10 Nm + Angle	C718643	1 - 10	•	116	30	73	39	56	21	26	13	55	1/4	–	0.21
Hex CS Multi 20 Nm	C718624	2 - 20	–	116	30	73	39	56	21	26	13	55	1/4	–	0.21
Hex CS Multi 20 Nm + Angle	C718644	2 - 20	•	116	30	73	39	56	21	26	13	55	1/4	–	0.21
CS Multi 5 Nm	C718625	0.5 - 5	–	72	30	73	10	56	5	7	13	55	–	1/4	0.20
CS Multi 5 Nm + Angle	C718645	0.5 - 5	•	72	30	73	10	56	5	7	13	55	–	1/4	0.20
CS Multi 10 Nm	C718626	1 - 10	–	72	30	73	10	56	5	7	13	55	–	1/4	0.20
CS Multi 10 Nm + Angle	C718646	1 - 10	•	72	30	73	10	56	5	7	13	55	–	1/4	0.20
CS Multi 20 Nm	C718627	2 - 20	–	72	30	73	10	56	5	7	13	55	–	1/4	0.20
CS Multi 20 Nm + Angle	C718647	2 - 20	•	72	30	73	10	56	5	7	13	55	–	1/4	0.20
CS Multi 25 Nm	C718628	2.5 - 25	–	77	30	77	13	56	8	11	15	59	–	3/8	0.24
CS Multi 25 Nm + Angle	C718648	2.5 - 25	•	77	30	77	13	56	8	11	15	59	–	3/8	0.24
CS Multi 50 Nm	C718629	5 - 50	–	77	30	77	13	56	8	11	15	59	–	3/8	0.24
CS Multi 50 Nm + Angle	C718649	5 - 50	•	77	30	77	13	56	8	11	15	59	–	3/8	0.24
CS Multi 75 Nm	C718630	7.5 - 75	–	77	30	77	13	56	8	11	15	59	–	3/8	0.24
CS Multi 75 Nm + Angle	C718650	7.5 - 75	•	77	30	77	13	56	8	11	15	59	–	3/8	0.24
CS Multi 180 Nm	C718631	18 - 180	–	87	42	88	17	58	12	15	21	70	–	1/2	0.43
CS Multi 180 Nm + Angle	C718651	18 - 180	•	87	42	88	17	58	12	15	21	70	–	1/2	0.43
CS Multi 250 Nm	C718632	25 - 250	–	106	52	99	25	60	21	21	26	80	–	3/4	0.76
CS Multi 250 Nm + Angle	C718652	25 - 250	•	106	52	99	25	60	21	21	26	80	–	3/4	0.76
CS Multi 500 Nm	C718633	50 - 500	–	106	52	99	25	60	21	21	26	80	–	3/4	0.76
CS Multi 500 Nm + Angle	C718653	50 - 500	•	106	52	99	25	60	21	21	26	80	–	3/4	0.76
CS Multi 750 Nm	C718634	75 - 750	–	125	63	110	32	65	29	26	32	92	–	1	1.50
CS Multi 750 Nm + Angle	C718654	75 - 750	•	125	63	110	32	65	29	26	32	92	–	1	1.50
CS Multi 1400 Nm	C718635	140 - 1400	–	125	63	110	32	65	29	26	32	92	–	1	1.50
CS Multi 1400 Nm + Angle	C718655	140 - 1400	•	125	63	110	32	65	29	26	32	92	–	1	1.50
CS Multi 3000 Nm	C718636	300 - 3000	–	181	102	154	44	87	51	39	51	136	–	1.5	5.7
CS Multi 3000 Nm + Angle	C718656	300 - 3000	•	181	102	154	44	87	51	39	51	136	–	1.5	5.7
CS Multi 5000 Nm	C718637	500 - 5000	–	181	102	154	44	87	51	39	51	136	–	1.5	5.7
CS Multi 5000 Nm + Angle	C718657	500 - 5000	•	181	102	154	44	87	51	39	51	136	–	1.5	5.7



Further information available on our website – 24/7.

Note: Various connecting cables are optionally available for connection to measuring instruments of other are optionally available. If required, please contact our technical consultants.