

Interchangeable Heads – Flare Nut (CCL 36.5 mm)

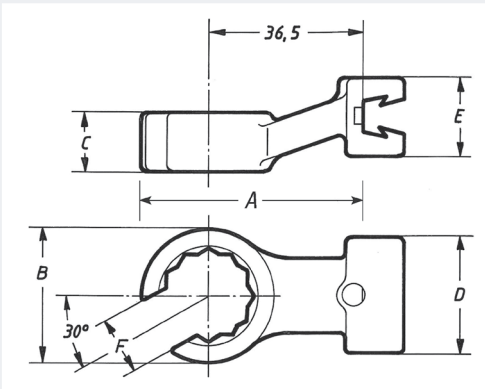

INFO
The term 'Common Center Line' means the distance from the base of the dovetail connector to the center of the rotary axis in the interchangeable head.

Sturtevant Richmond achieves an exactly constant center distance through the special manufacturing process – from one casting.

Flare Nut (FN) interchangeable head with Sturtevant Richmond dovetail connector. Cast as a single piece from alloy steel. The manufacturing method provides strength and durability rarely attained by the more common "cut & weld" method. FN flare nut heads are ideal, when:

- » Working on pneumatic, hydraulic or other connections involving tubing,
- » There is not room to fit an OE or ROE head into the space at the connection.

These interchangeable attachments from Sturtevant Richmond are cast in one piece from alloyed tool steel, resulting in an **exactly constant centre distance**. This means that these tool heads can be interchanged as required without having to adjust the torque setting. The dovetail profile is also always the same and therefore each SR dovetail head fits every SR dovetail torque wrench.

- ▶ Open 12-point ring spanner with 30 degrees opening offset.
- ▶ Sturtevant Richmond dovetail connector with outstanding rigidity and wear resistance.
- ▶ **One-piece cast** alloy steel, black finished.
- ▶ **Common centre line 36.5 mm** (1 7/16").
- ▶ Can be used with multiple dovetail torque wrenches, e.g.
 - ✓ Series LTC, SLTC, SLTC-FM
 - ✓ Series DTC
 - ✓ Series CCM up to 200 Nm / 1800i / 150 ft
 - ✓ Series Exacta up to 200 Nm / 1800i / 150 ft
 - ✓ Series TAC



Each SR dovetail head fits on every SR dovetail wrench.

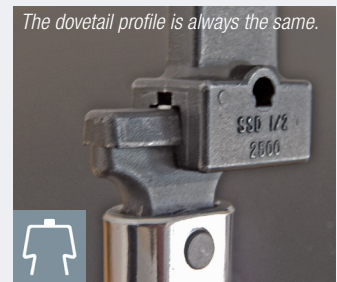

The dovetail profile is always the same.

INFO
Several models of this dovetail head series have NATO approval.

FN – metric

Model	Item No.	A/F mm	max N-m	Dimensions mm					
				A	B	C	D	E	F
FN-8 MM	R809243	8	16	45.7	19.1	9.5	19.1	20.6	6.4
FN-9 MM	R809217	9	19	45.7	21.4	9.5	19.1	20.6	7.1
FN-10 MM	R809218	10	22	45.7	21.4	9.5	19.1	20.6	7.9
FN-11 MM	R809221	11	28	45.7	21.4	9.5	19.1	20.6	8.7
FN-12 MM	R809241	12	30	48.3	24.6	10.3	22.2	20.6	9.5
FN-13 MM	R809219	13	33	48.3	24.6	10.3	22.2	20.6	9.5
FN-14 MM	R809220	14	40	50.8	27.0	11.9	25.4	23.8	11.1
FN-15 MM	R809222	15	45	50.8	28.6	13.5	25.4	23.8	11.1
FN-16 MM	R809238	16	50	50.8	28.6	13.5	25.4	23.8	13.5
FN-17 MM	R809223	17	54	53.3	31.8	14.3	25.4	23.8	13.5
FN-18 MM	R809239	18	61	53.3	31.8	14.3	25.4	23.8	15.1
FN-19 MM	R809224	19	68	53.3	33.3	14.3	25.4	23.8	15.1
FN-21 MM	R809240	21	80	53.3	38.1	16.7	31.8	23.8	17.5
FN-22 MM	R809242	22	90	55.9	38.1	16.7	31.8	23.8	17.5
FN-24 MM	R809225	24	105	55.9	39.7	18.3	31.8	23.8	18.3

FN – inch

Model	Item No.	A/F inch	max. lbf-in	Dimensions mm					
				A	B	C	D	E	F
FN-1/4	R819025	1/4	100	44.4	15.9	8.7	19.1	20.6	4.8
FN-5/16	R819026	5/16	150	46.0	19.1	9.5	19.1	20.6	5.6
FN-3/8	R819027	3/8	200	47.2	21.4	9.5	19.1	20.6	7.1
FN-7/16	R819028	7/16	250	47.2	21.4	9.5	19.1	20.6	8.7
FN-1/2	R819029	1/2	300	50.0	24.6	10.3	22.2	20.6	9.5
FN-9/16	R819030	9/16	350	50.0	27.0	11.9	25.4	23.8	11.1
FN-5/8	R819031	5/8	400	50.8	28.6	13.5	25.4	23.8	11.9
FN-11/16	R819032	11/16	475	52.4	31.8	14.3	25.4	23.8	13.5
FN-3/4	R819033	3/4	600	52.4	33.3	14.3	25.4	23.8	14.3
FN-13/16	R819034	13/16	700	57.2	36.5	15.9	31.8	23.8	15.9
FN-7/8	R819035	7/8	800	57.2	38.1	16.7	31.8	23.8	17.5
FN-15/16	R819036	15/16	900	60.3	39.7	18.3	31.8	23.8	18.3
FN-1	R819037	1	1000	63.5	39.7	18.3	31.8	23.8	19.1
FN-1 1/16	R819038	1 1/16	1050	63.5	52.4	22.2	31.8	23.8	19.8
FN-1 1/4	R819041	1 1/4	1200	63.5	52.4	22.2	31.8	23.8	22.2

