

Interchangeable Dovetail Heads – Square Drive

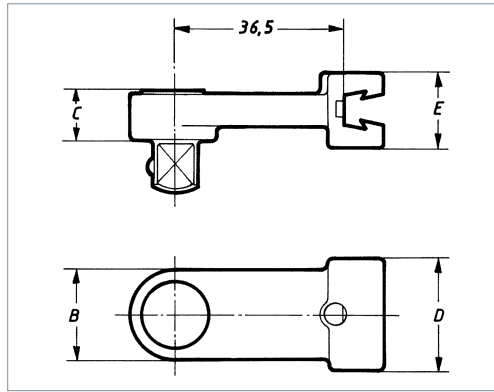

INFO
 The term 'Common Center Line' means the distance from the base of the dovetail connector to the center of the rotary axis in the interchangeable head.
 Sturtevant Richmond achieves an exactly constant center distance through the special manufacturing process – from one casting.

Sturtevant Richmond's **Square Drive** interchangeable heads are ideal when...

- ➔ the torque wrench is calibrated on a tester;
- ➔ the bolt/nut can be tightened with a socket wrench;
- ➔ a small amount of rotation is all that is required to achieve the specified torque.

These Sturtevant Richmond interchangeable heads are cast in one piece from alloy tool steel, resulting in a **precisely consistent center line**. As a result, these tool heads can be interchanged at will without having to adjust the torque setting. Also, the dovetail profile is always the same and therefore fits all dovetail torque wrenches and SR interchangeable heads.

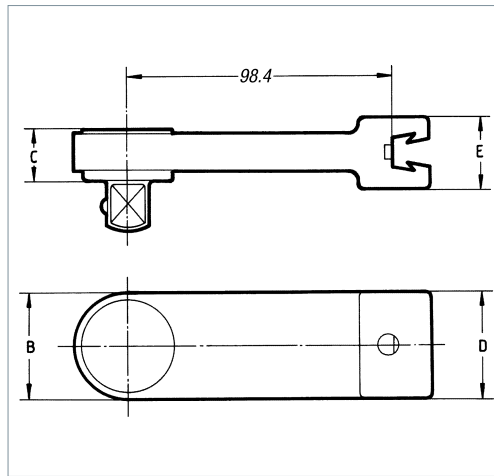

- ➔ Rigid square drive with spring ball lock.
- ➔ SR dovetail tool connector profile with superior bending stiffness and legendary wear resistance.
- ➔ One-piece cast Alloy Steel, black oxide finish.
- ➔ **Common Center Lines:**

- ◇ **36.5 mm** (1 7/16"); to be used with dovetail torque wrench up to 200 Nm (1800 lbf-in) capacity.
- ◇ **98.4 mm** (3 7/8"); to be used with dovetail torque wrench above 200 Nm (1800 lbf-in) capacity.

INFO
 Sturtevant Richmond's micrometer and digital torque wrenches up to 200 Nm capacity are designed for interchangeable heads with 36.5 mm (1 7/16") center line; above 200 Nm capacity, these wrenches are designed for interchangeable heads with 98.4 mm (3 7/8") center line. Otherwise, the scaling must not be applied due to the deviating lever length.

INFO
 Tool heads of the same center line can be interchanged at will without having to re-adjust the torque wrench.
 However, when interchanging heads with different center lines, the torque must be re-adjusted each time!

- NATO approval (NSN)**
- SD-1/4 = 5120-01-394-4304
 - SD-3/8 = 5120-01-394-4305
 - SD-1/2 = 5120-01-394-4302

SD – Center Line 98.4 mm

Model	Item No.	SqD inch	max. N-m	Dimensions mm				
				A	B	C	D	E
SD-3/4	R819119	¾	542	130.6	38.1	17	38.1	25.4

SD – Center Line 36.5 mm

Model	Item No.	SqD inch	max. N-m	Dimensions mm				
				A	B	C	D	E
SD-1/4	R819057	¼	28.2	44.4	14.3	19.1	19.1	17.5
SD-3/8	R819058	⅜	141.2	47.6	22.2	22.2	28.6	20.6
SD-1/2	R819059	½	282.5	49.2	22.2	25.4	28.6	20.6

