

# Preset Clicker Torque Wrench – LTC



## The Workhorse

The Sturtevant Richmond **LTC** (*Limiting Torque Control*) torque wrench is a professional and extremely durable assembly option! It is used worldwide in industry in the production area where the same tightening torques are required. The durability of the LTC is legendary. Users report that this tool retains its repeatability for decades.

It is ideal for any application where:

- the fastener cannot readily be engaged with a socket,
- the same torque is to be applied repeatedly,
- it is advisable to eliminate the possibility of having the operator set the wrong torque on the tool,
- simplicity and high operator efficiency are needed,
- very high durability is important.

These needs are common in assembly and standardized field maintenance operations, and the LTC Series tools are superb for these types of applications. A pin lock on the dovetail assures positive head connection, yet permits head changeover in seconds.

The strong dimensioned torque spring is the very heart of this clicker wrench. When reaching the pre-set torque, the torque spring is squeezed slightly, and the hardwearing pawl is releasing the tool tang. An excellent tactile and audible impulse signals that the pre-set torque is achieved. The precise adjustment mechanism prevents torque changes even under the toughest production conditions.

SR's unique dovetail design, which joins the attachment head and torque wrench together, provides an exceptionally strong connection and also grants complete interchangeability of the heads – the dovetail profile is always the same.

- ▶ Ergonomically optimised handle.
- ▶ SR **dovetail** connector with outstanding rigidity and wear resistance.
- ▶ Over 200 different SR dovetail interchangeable heads available.
- ▶ Thick-walled flat profile provides excellent bending stiffness and durability.
- ▶ Accuracy  $\pm 4\%$  of indicated value (within 20-100% of rated capacity).
- ▶ Meets or exceeds **ASME B107.300-2010** and **EN ISO 6789**.
- ▶ **Precise torque adjustment** with optional C.A.R.T. on appropriate torque tester.



The optional "CART" is a specialty tool used to set the torque on all SR preset clicker torque wrenches.  
Ordering P/N: R819117



There are over 200 different interchangeable dovetail heads to choose from – any of them fits.

Option: Preset delivery ex works

**INFO**

available on request.

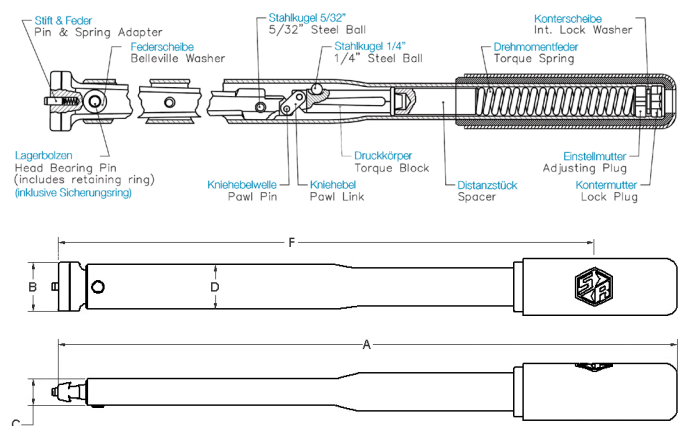

LTC												
Model	Part No.	Torque Range*			Weight	– Dimensions (mm) –						Grip style
		N-m	lbf-in	lbf-ft		A	B	C	D	F		
LTC-50i	R810100	1.2 - 5.6	10 - 50	0.8 - 4	0.28	176.1	19.1	12.7	23.8	142.2	soft	
LTC-150i	R810011	4 - 17	30 - 150	2.5 - 12.5	0.29	176.1	19.1	12.7	23.8	142.2	soft	
LTC-300i OHT	R810574	17 - 34	150 - 300	12.5 - 25	0.29	176.1	19.1	12.7	23.8	142.2	soft	
LTC-300i	R810016	7 - 34	60 - 300	5 - 25	0.39	226.8	19.1	12.7	23.8	184.5	soft	
LTC-750i	R810013	17 - 85	150 - 750	12.5 - 62.5	0.55	323.4	25.4	12.7	23.8	264.3	soft	
LTC-1800i	R810014	40 - 200	360 - 1800	30 - 150	0.73	410.9	28.6	12.7	23.8	368.7	soft	
LTC-1800i ERGO	R810054	80 - 200	720 - 1800	60 - 150	0.7	521.7	28.6	12.7	23.8	n. a.	soft	
LTC-3000i	R810802	70 - 340	600 - 3000	50 - 250	2.2	528.1	44.5	15.9	50.8	469.1	soft	
LTC-3600i	R810334	80 - 400	720 - 3600	60 - 300	2.5	617.5	44.5	15.9	50.8	530.2	MG	
LTC-4800i	R810137	110 - 540	960 - 4800	80 - 400	3.7	872.3	44.5	15.9	50.8	784.2	MG	

\* It is recommended to primarily use in medium performance range (approx. 1/3 to 4/5 of rated capacity). If you regularly worked close to the limit of load (maximum capacity), a larger model or tool might be more advisable. MG = Knurled Metal Grip.

