

## Preset Clicker Torque Wrench – MiniTorq

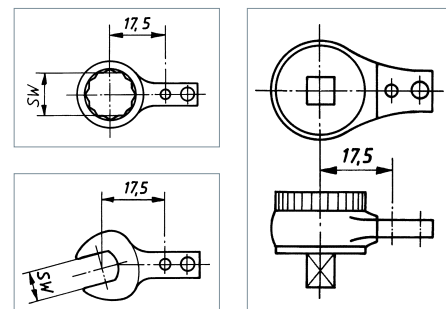

### Preset Clicker Torque Wrench

Sturtevant Richmond's smallest preset torque wrench delivers consistent assembly quality. Designed for assembly operations where access is limited and low torque capacities are required.

The target torque is steplessly adjustable by means of the included adjusting tool and a torque tester (not included), enhancing assurance that the proper torque is set on the wrench. A tactile impulse and audible click are emitted when the pre-set torque is reached, making it easy for the operator to perform the torque application process properly. The MiniTorq releases in both directions – right and left.

More than two dozens of different interchangeable heads are available as standard. Further sizes and/or special tools are available on request.

- ▶ Simple to preset & use clicker torque wrench with interchangeable heads.
- ▶ Audible click and tactile impulse in both directions – cw or ccw.
- ▶ Oil-proof and chemicals resisting smooth vinyl handle.
- ▶ Meets or exceeds ASME B107.300-2010, GGG-W-686E and DIN EN ISO 6789.
- ▶ Accuracy  $\pm 6\%$  of indicated value (within 20-100% of rated capacity).
- ▶ Good ergonomics.
- ▶ Slender design.
- ▶ Light weight.

### Ratchet Head

Model	Part No.	Sq.Drv. inch	CCL mm
MSDRT-1/4	R712561	1/4	17.5

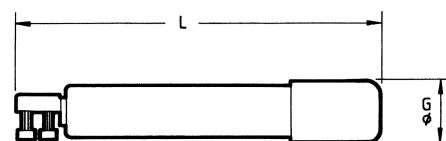

### Box Head

Model	Part No.	A/F mm	CCL mm	Model	Part No.	A/F inch	CCL mm
MBH-5	R809675	5	17.5	MBH-3/16	R809602	3/16	17.5
MBH-5.5	R809676	5.5	17.5	MBH-1/4	R809603	1/4	17.5
MBH-6	R809677	6	17.5	MBH-5/16	R809604	5/16	17.5
MBH-7	R809678	7	17.5	MBH-11/32	R809605	11/32	17.5
MBH-8	R809679	8	17.5	MBH-3/8	R809606	3/8	17.5
MBH-10	R809680	10	17.5				

### Open End Head

Model	Part No.	A/F mm	CCL mm	Model	Part No.	A/F inch	CCL mm
MOE-5	R809651	5	17.5	MOE-3/16	R809627	3/16	17.5
MOE-5.5	R809652	5.5	17.5	MOE-1/4	R809628	1/4	17.5
MOE-6	R809653	6	17.5	MOE-5/16	R809629	5/16	17.5
MOE-7	R809654	7	17.5	MOE-11/32	R809630	11/32	17.5
MOE-8	R809655	8	17.5	MOE-3/8	R809631	3/8	17.5
MOE-10	R809656	10	17.5				

### MiniTorq

Model	Part No.	Torque Range (ISO)*				Weight kg	Dimensions (mm)	
		cN-m	N-m	ozf-in	lbf-in		L	G
Mini-Torq	R810638	113 - 565	1.1 - 5.6	160 - 800	10 - 50	0.088	104.8	14.3



Further info on our website. 24/7

\* It is recommended to primarily use in medium performance range (approx. 1/3 to 4/5 of rated capacity). If users would regularly work close to the capacity limit, a larger model may be more convenient.