

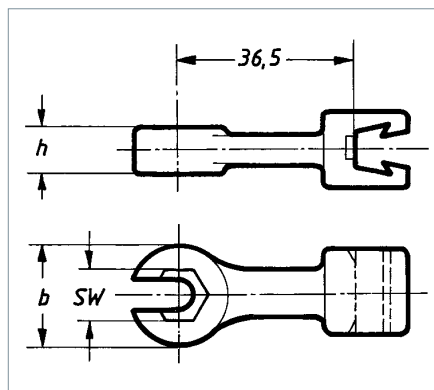

# Interchangeable Heads – Shoulder Flare Nut (36.5 mm)

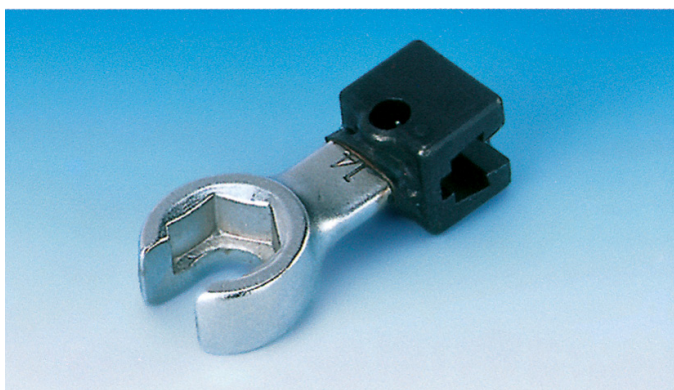

Shoulder flare nut interchangeable head with Sturtevant Richmond dovetail connector. Especially applicable for tightening brake hoses, oil pressure lines or control lines. Suitable for Sturtevant Richmond torque wrench series CCM up to 200 Nm / 1800i / 150 ft.lb, series LTC, series SLTC, and series SLTC-FM.

The unique SR dovetail design used to join head and wrench provides an exceptionally strong connection and allows complete interchangeability. The SR system contributes to both operational flexibility and enhancing your return on investment!

To achieve constant torque values when changing heads, exact lever length must be maintained. Virtually all SR heads share a precise distance from end of wrench to center of fastener. This is referred to as a "Common Centre Line" and is very difficult to maintain using the cut and weld construction method.

**Note:** Other sizes and/or special designs are available on request.

- ▶ Offener Sechskant-Ringschlüssel mit Anschlag (Schulter)
- ▶ SR dovetail tool attachment with outstanding flexural rigidity and wear resistance
- ▶ Tool steel, partially chrome-plated/black finished
- ▶ **Common centre line 36.5 mm (1 7/16")**
- ▶ Can be used with dovetail torque wrench
  - ✓ Series LTC, BLT
  - ✓ Series SLTC, SLTC-FM
  - ✓ Series DTC
  - ✓ Series CCM up to 200 Nm / 1800i / 150 ft.lb
  - ✓ Series Exacta up to 200 Nm / 1800i / 150 ft.lb

### INFO

*We also manufacture customised special tools for you according to drawings. Please contact us if required.*

*Shown here is an offset open-end spanner with a dovetail tool connector.*

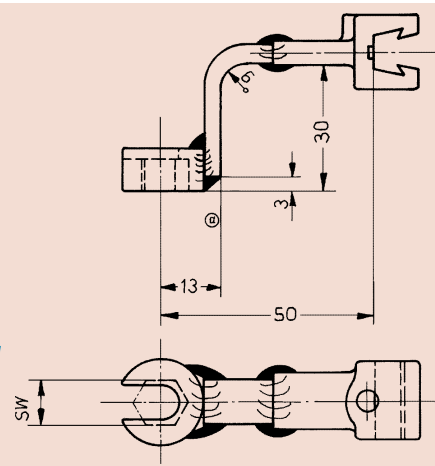

### S-FN – metric

Model	Item No.	A/F mm	max. N-m	Dimensions mm			
				B	H	–	–
S-FN 10 MM	R712362	10	–	19.1	11.1	–	–
S-FN 11 MM	R712519	11	–	19.8	11.1	–	–
S-FN 12 MM	R712363	12	–	22.2	11.9	–	–
S-FN 13 MM	R712520	13	–	23.0	11.9	–	–
S-FN 14 MM	R712521	14	–	24.6	12.7	–	–
S-FN 17 MM	R712390	17	–	28.6	13.5	–	–
S-FN 19 MM	R712448	19	–	31.8	13.5	–	–



Further info on our website. 24/7