

NOTE: ALL INTERFACING CABLES HAVE ELECTRICAL RATING 60 VAC/75VDC AND HOLD A MAXIMUM OF 3 AMPS.

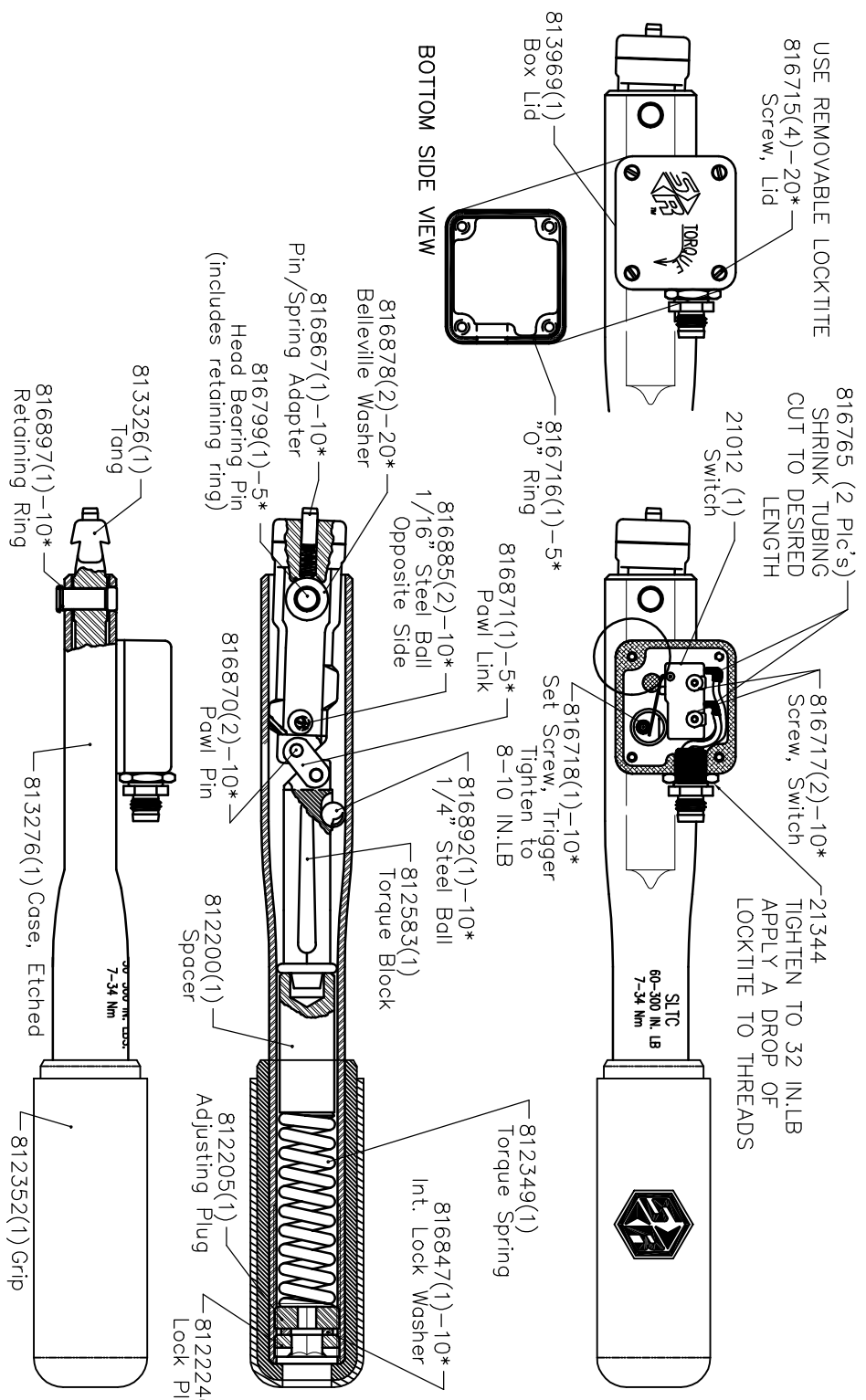

816799-THIS PIN IS FORMED OVER CUSTOMER MUST GRIND OFF FORMED END & INSTALL THIS PIN FORMING THE HEAD OVER THE RETAINING RING AS SHOWN.

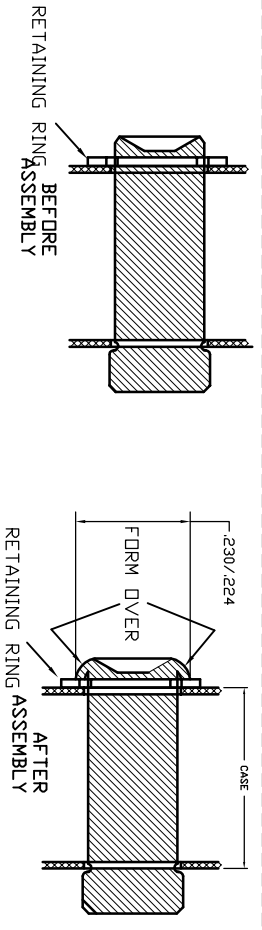

857010-Service Instructions
811372-Tang Ass'y. (Includes Tang & Pin/Spring Adapter)

LEGEND: () = Quantity/Tool
* = Quantity/Multi-Pak



THIS PRINT AND ALL INFORMATION APPEARING THEREON IS THE PROPERTY OF "STURTEVANT/RICHMONT". NEITHER THE PRINT NOR THE INFORMATION THEREON MAY BE REPRODUCED OR USED IN ANY MANNER WHATSOEVER OR DIVULGED TO ANY OTHER PERSON UNLESS SPECIFICALLY AUTHORIZED BY "STURTEVANT/RICHMONT".

PART DESCRIPTION
SLTC 300-CT (IN./LBS)

DIAGRAM NO. & REV.
810855-F